

1. DESCRIPTION

The M37161M8/MA/MF-XXXSP/FP and M37161EFSP/FP are single-chip microcomputers designed with CMOS silicon gate technology. They have an OSD and I²C-BUS interface, making them perfect for a channel selection system for TV.

The M37161EFSP/FP has a built-in PROM that can be written electrically.

2. FEATURES

- Number of basic instructions 71
- Memory size
 - ROM 32K bytes (M37161M8-XXXSP/FP)
40K bytes (M37161MA-XXXSP/FP)
60K bytes (M37161MF-XXXSP/FP,
M37161EFSP/FP)
 - RAM 1152 bytes (M37161M8-XXXSP/FP)
1472 bytes (M37161MA/MF-XXXSP/FP,
M37161EFSP/FP)

(*ROM correction memory included)
- Minimum instruction execution time
..... 0.5 μs (X_{IN} = 8 MHz oscillation frequency)
- Power source voltage 5 V ± 10 %
- Subroutine nesting 128 levels (Max.)
- Interrupts 16 types, 15 vectors
- 8-bit timers 6
- Programmable I/O ports (Ports P0, P1, P2, P30, P31) 25
- Input ports (Ports P35-P37, P50, P51) 5
- Output ports (Ports P52-P55) 4
- Serial I/O 8-bit X 1 channel
- Multi-master I²C-BUS interface 1 (3 systems)
- A-D comparator (7-bit resolution) 8 channels
- PWM output circuit 14-bit X 1, 8-bit X 5
- Power dissipation
 - In high-speed mode 165 mW
(at V_{CC} = 5.5V, 8 MHz oscillation frequency, OSD on)
 - In low-speed mode 0.33 mW
(at V_{CC} = 5.5V, 32 kHz oscillation frequency)
- ROM correction function 2 vectors

● OSD function

- Display characters 32 characters X 2 lines
(It is possible to display 3 lines or more by software)
- Kinds of characters 254 kinds + 62 kinds
(coloring unit) (per character unit) (per dot unit)
- Character display area OSD1 mode: 16 X 26 dots
OSD2 mode: 16 X 20 dots
CD OSD mode: 16 X 20 dots
- Kinds of character sizes OSD1 mode: 1 kind
OSD2 mode: 8 kinds
CD OSD mode: 8 kinds
- Kinds of character colors 8 colors (R, G, B)
- Coloring unit dot, character, character background, raster
- Display position
Horizontal: 128 levels Vertical: 512 levels
- Attribute
OSD1 mode: smooth italic, underline, flash, automatic solid space
OSD2 mode: border
- Smooth roll-up
- Window function

3. APPLICATION

TV

TABLE OF CONTENTS

1. DESCRIPTION	1	8.17 MACHINE INSTRUCTIONS	89
2. FEATURES	1	9. TECHNICAL NOTES	89
3. APPLICATION	1	10. ABSOLUTE MAXIMUM RATINGS	90
4. PIN CONFIGURATION	3	11. RECOMMENDED OPERATING CONDITIONS	90
5. FUNCTIONAL BLOCK DIAGRAM	4	12. ELECTRIC CHARACTERISTICS	91
6. PERFORMANCE OVERVIEW	5	13. A-D CONVERTER CHARACTERISTICS	93
7. PIN DESCRIPTION	7	14. MULTI-MASTER I ² C-BUS BUS LINE CHARACTERISTICS	93
8. FUNCTIONAL DESCRIPTION	11	15. PROM PROGRAMMING METHOD	94
8.1 CENTRAL PROCESSING UNIT (CPU)	11	16. DATA REQUIRED FOR MASK ORDERS	95
8.2 MEMORY	12	17. ONE TIME PROM VERTION M37161EFSP/FP MARKING	96
8.3 INTERRUPTS	17	18. Appendix	97
8.4 TIMERS	22	19. PACKAGE OUTLINE	126
8.5 SERIAL I/O	26		
8.6 MULTI-MASTER I ² C-BUS INTERFACE	29		
8.7 PWM OUTPUT FUNCTION	42		
8.8 A-D COMPARATOR	47		
8.9 ROM CORRECTION FUNCTION	49		
8.10 OSD FUNCTIONS	50		
8.10.1 Display Position	55		
8.10.2 Dot Size	59		
8.10.3 Clock for OSD	60		
8.10.4 Field Determination Display	60		
8.10.5 Memory for OSD	62		
8.10.6 Character color	68		
8.10.7 Character background color	68		
8.10.8 OUT signals	69		
8.10.9 Attribute	70		
8.10.10 Multiline Display	75		
8.10.11 Automatic Solid Space Function	76		
8.10.12 Scan Mode	77		
8.10.13 Window Function	77		
8.10.14 OSD Output Pin Control	79		
8.10.15 Raster Coloring Function	80		
8.11 SOFTWARE RUNAWAY DETECT FUNCTION	82		
8.12 RESET CIRCUIT	83		
8.13 CLOCK GENERATING CIRCUIT	84		
8.14 CLOCK GENERATING CIRCUIT	88		
8.15 AUTO-CLEAR CIRCUIT	89		
8.16 ADDRESSING MODE	89		

4. PIN CONFIGURATION

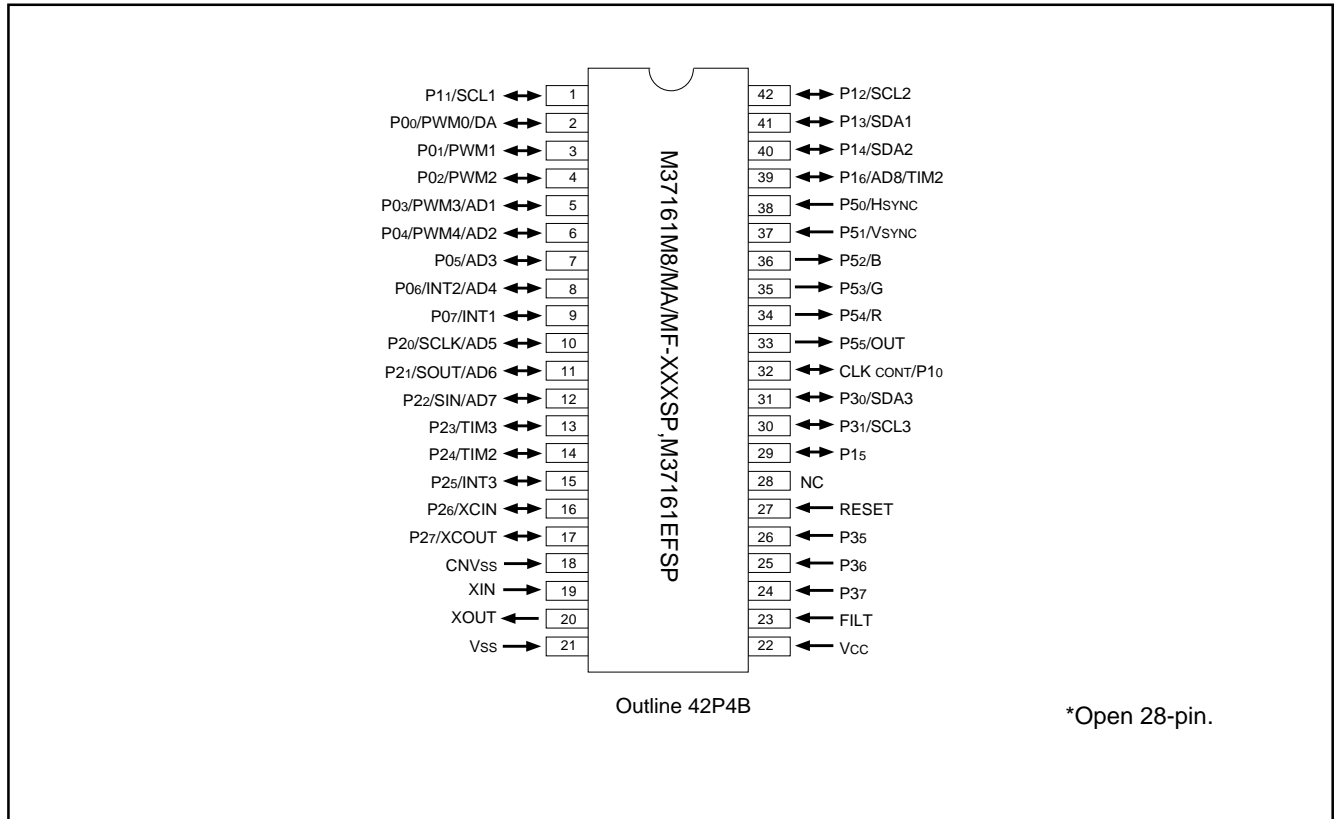

Fig. 4.1 Pin Configuration (Top View)

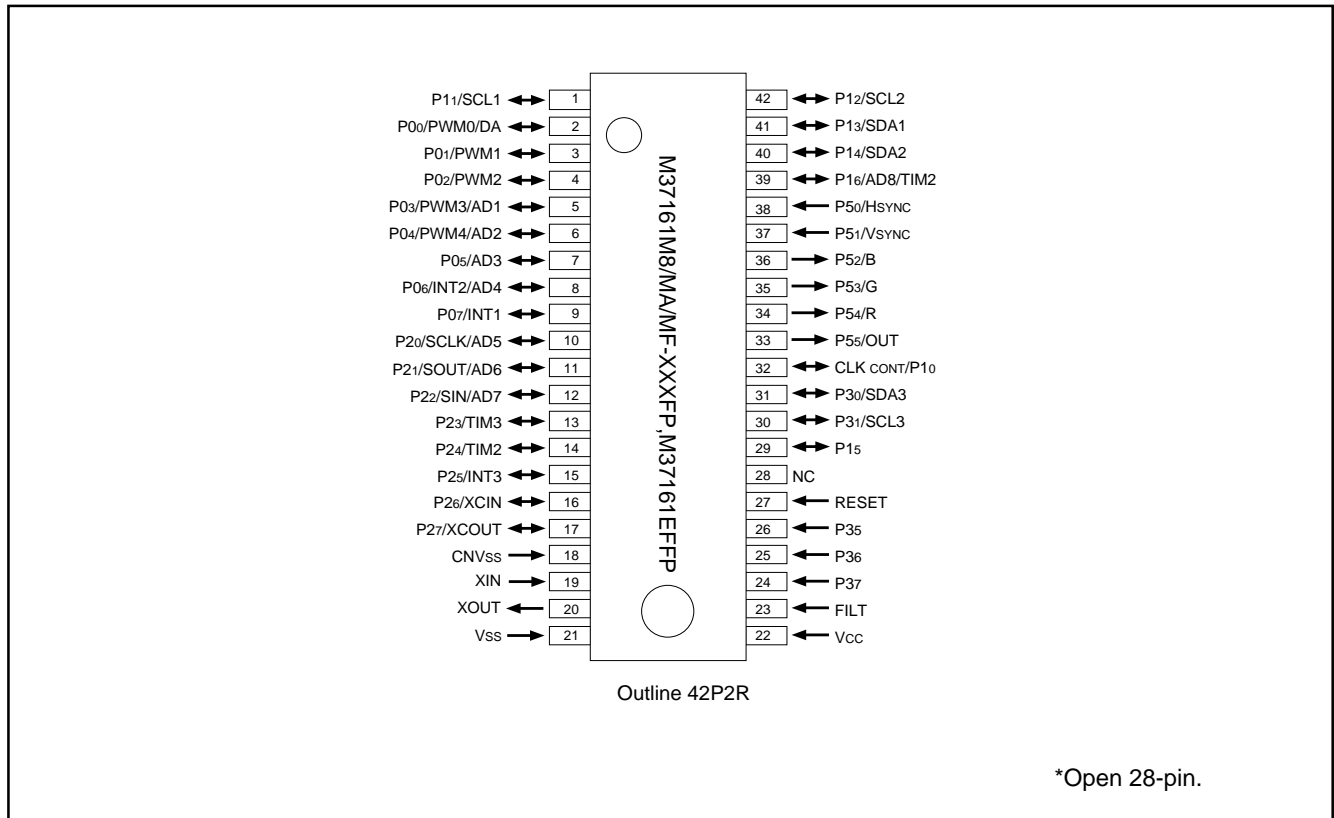

Fig. 4.2 Pin Configuration (Top View)

5. FUNCTIONAL BLOCK DIAGRAM

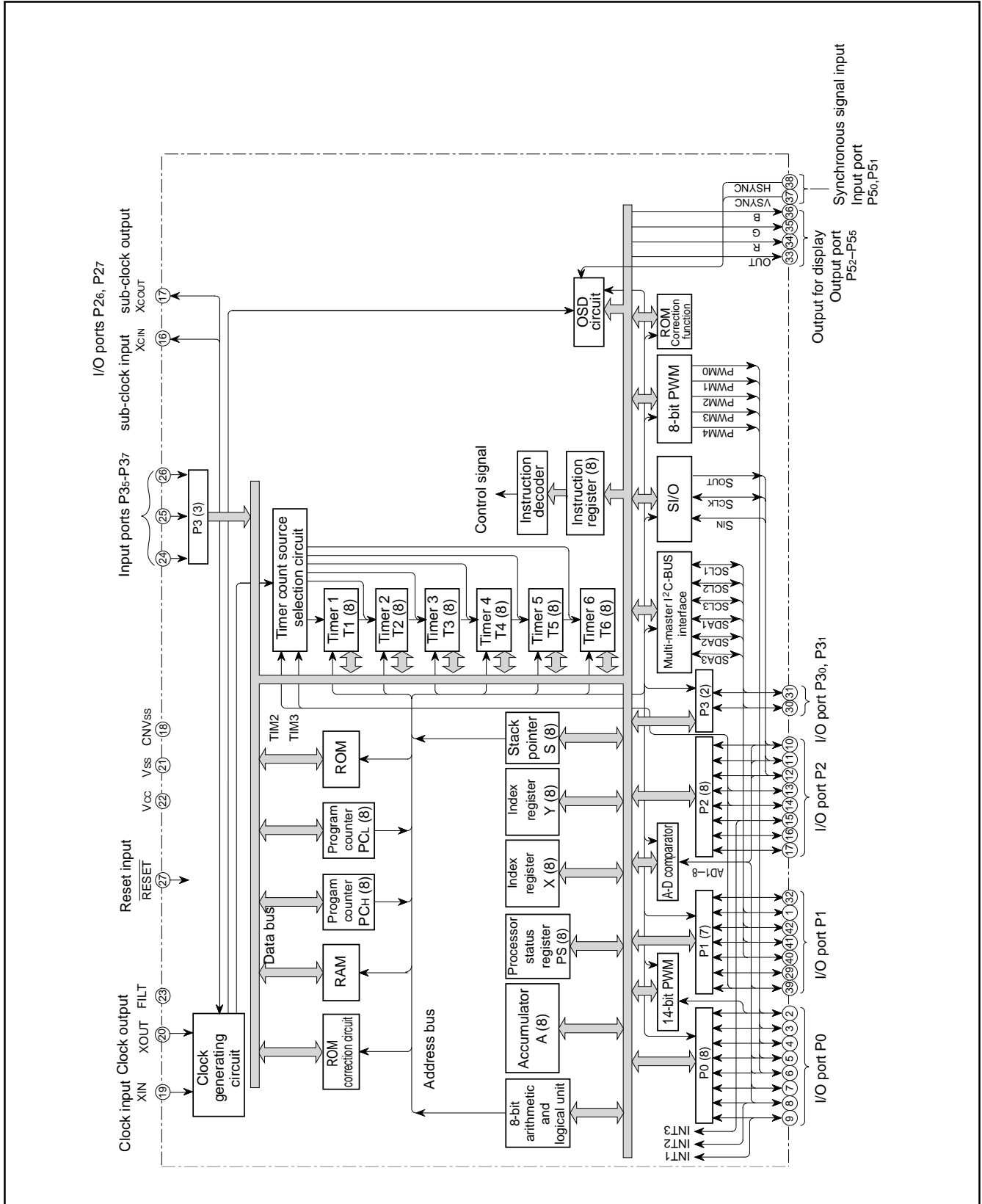

Fig. 5.1 Functional Block Diagram of M37161

6. PERFORMANCE OVERVIEW

Table 6.1 Performance Overview

Parameter		Functions	
Number of basic instructions		71	
Instruction execution time		0.5 ms (the minimum instruction execution time, at 8 MHz oscillation frequency)	
Clock frequency		8 MHz (maximum)	
Memory size	ROM	M37161M8-XXXSP/FP	32K bytes
		M37161MA-XXXSP/FP	40K bytes
		M37161MF-XXXSP/FP,M37161EFSP/FP	60K bytes
	RAM	M37161M8-XXXSP/FP	1152 bytes (ROM correction memory included)
		M37161MA/MF-XXXSP/FP,M37161EFSP/FP	1472 bytes (ROM correction memory included)
	OSD ROM		20K bytes
OSD RAM		128 bytes	
Input/Output ports	P0	I/O	8-bit X 1 (N-channel open-drain output structure, can be used as 8-bit PWM output pins, INT input pins, A-D input pin, 14-bit PWM output pins. However, CMOS output structure, when P0 ₀ is used as serial output.)
	P10–P16	I/O	7-bit X 1 (CMOS input/output structure, however, N-channel open-drain output structure, when P1 ₁ –P1 ₄ are used as multi-master I ² C-BUS interface, can be used as A-D input pins, timer external clock input pins, multi-master I ² C-BUS interface)
	P20–P27	I/O	8-bit X 1 (P2 is CMOS input/output structure, however, N-channel open-drain output structure when P2 ₀ and 2 ₁ are used as serial output, can be used as serial input/output pins, timer external clock input pins, A-D input pins, INT input pin, sub-clock input/output pins)
	P30, P31	I/O	2-bit X 1 (CMOS input/output structure, however, N-channel open-drain output structure, when used as multi-master I ² C-BUS interface, can be used as multi-master I ² C-BUS interface.)
	P35–P37	Input	3-bit X 1
	P50, P51	Input	2-bit X 1 (can be used as OSD input pins)
	P52–P55	Output	4-bit X 1 (CMOS output structures, can be used as OSD output pins)
Serial I/O		8-bit X 1	
Multi-master I ² C-BUS interface		One (Three lines)	
A-D comparator		8 channels (7-bit resolution)	
PWM output circuit		14-bit X 1, 8-bit X 5	
Timers		8-bit X 6	
ROM correction function		2 vectors	
Subroutine nesting		128 levels (maximum)	
Interrupt		<16 types> INT external interrupt X 3, Internal timer interrupt X 6, Serial I/O interrupt X 1, OSD interrupt X 1, Multi-master I ² C-BUS interface interrupt X 1, f(XIN)/4096 interrupt X 1, V _{SYNC} interrupt X 1, BRK instruction interrupt X 1, reset X 1	
Clock generating circuit		2 built-in circuits (externally connected to XCIN/OUT is a ceramic resonator or a quartz-crystal oscillator)	

Table 6.2 Performance Overview (Continued)

Parameter		Functions	
OSD function	Number of display characters	32 characters X 2 lines	
	Dot structure	OSD1 mode: 16 X 26 dots (character display area : 16 X 20 dots) OSD2 mode: 16 X 20 dots CD OSD mode: 16 X 20 dots	
	Kinds of characters	254 kinds + 62 kinds	
	Kinds of character sizes 1 screen : 8	OSD1 mode: 1 kinds OSD2 mode: 8 kinds CD OSD mode: 8 kinds	
	Character font coloring	1 screen: 8 kinds OSD1 mode, OSD2 mode : per character unit CD OSD mode : per dot unit	
	Display position	Horizontal: 128 levels, Vertical: 512 levels	
Power source voltage		5V ± 10%	
Power dissipation	In high-speed mode	OSD ON	165 mW typ. (at oscillation frequency f(XIN) = 8 MHz, fOSC = 26 MHz)
		OSD OFF	82.5 mW typ. (at oscillation frequency f(XIN) = 8MHz)
	In low-speed mode	OSD OFF	0.33 mW typ. (at oscillation frequency f(XCIN) = 32 kHz)
		In stop mode	
Operating temperature range		-10 °C to 70 °C	
Device structure		CMOS silicon gate process	
Package		42-pin plastic molded SSOP	
		42-pin plastic molded SDIP	

7. PIN DESCRIPTION

Table 7.1 PIN DESCRIPTION

Pin	Name	Input/ Output	Functions
VCC, VSS	Power source		Apply voltage of 5 V \pm 10 % to (typical) VCC, and 0 V to VSS.
CNVSS	CNVSS		This is connected to VSS.
RESET	Reset input	Input	To enter the reset state, the reset input pin must be kept at a LOW for 2 ms or more (under normal VCC conditions). If more time is needed for the quartz-crystal oscillator to stabilize, this LOW condition should be maintained for the required time.
XIN	Clock input	Input	This is the input pin for the main clock generating circuit. Built-in clock generation circuit, when set
XOUT	Clock output	Output	to oscillation frequency, connect ceramic resonator or crystal frequency between XIN and XOUT. When use external clock input, connect clock oscillation source to XIN pin, and open XOUT pin.
P00/PWM0/DA, P01/PWM1, P02/PWM2,	I/O port P0	I/O	Port P0 is a 8-bit I/O port with a direction register allowing each I/O bit to be individually programmed as input or output. At reset, this port is set to input mode. The output structure is N-channel open-drain output. (See note)
P03/PWM3/AD1, P04/PWM4/AD2,	8-bit PWM output	Output	Output Pins P00 to P04 are also used as 8-bit PWM output pins PWM0 to PWM4, respectively. The output structure is N-channel open-drain output.
P05/AD3,	DA output	Output	P00 pin is also used as 14-bit PWM output pin DA. The output structure is CMOS.
P06/INT2/AD4, P07/INT1	External interrupt input	Input	Pins P06 and P07 are also used as INT external interrupt input pins INT2 and INT1 respectively.
	Analog input	Input	Pins P03, P04, P05 and P06 are also used as analog input pins AD1, AD2, AD3 and AD4, respectively.
P10/CLK CONT, P11/SCL1,	I/O port P1	I/O	Port P1 is a 7-bit I/O port and has basically the same functions as port P0. The output structure is CMOS output. (See note)
P12/SCL2, P13/SDA1, P14/SDA2, P15,	Multi-master I ² C-BUS interface	I/O	Pins P11–P14 are used as SCL1, SCL2, SDA1 and SDA2 respectively, when multi-master I ² C-BUS interface is used. The output structure is N-channel open-drain output.
P16/AD8/TIM2	Clock control	Output	P10 pin is also used as Clock control output CLK CONT. The output structure is CMOS output.
	External clock input for timer	Input	P16 pin is also used as timer external clock input pin TIM2.
	Analog input	Input	P16 pin is also used as analog input pin AD8.
P20/SCLK/AD5, P21/SOUT/AD6,	I/O port P2	I/O	Port P2 is a 8-bit I/O port and has basically the same functions as port P0. The output structure is CMOS output. (See note)
P22/SIN/AD7, P23/TIM3,	Serial I/O synchronous clock input/output port	I/O	P20 pin is also used as serial I/O synchronous clock input/output pin SCLK. The output structure is N-channel open-drain output.
P24/TIM2, P25/INT3,	Serial I/O data output	Output	P21 pin is also used as serial I/O data output pin SOUT. The output structure is open-drain output.
P26/XCIN, P27/XCOUT	Serial I/O data input	Input	P22 pin is also used as serial I/O data input pin SIN.
	External clock input for timer	Input	Pins P23 and P24 are also used as timer external clock input pins TIM3 and TIM2 respectively.
	Analog input	Input	Pins P20–P22 are also used as analog input pins AD5, AD6 and AD7 respectively.
	Sub-clock input	Input	P26 pin is also used as sub-clock input pin XCIN.
	Sub-clock output	Output	P27 pin is also used as sub-clock output pin XCOUT. The output structure is CMOS output.
	External interrupt input	Input	P25 pin is also used as INT external interrupt input pin INT3.
P30/SDA3 P31/SCL3 P35-P37	I/O port P30, P31	I/O	Pins P30 and P31 are 2-bit I/O port and has basically the same functions as port P0. The output structure is CMOS output. (See note)
	Multi-master I ² C-BUS Interface	I/O	Pins P30 and P31 are used as SDA3, SCL3 respectively, when multi-master I ² C-BUS interface is used. The output structure is N-channel open-drain output.
	Input P35-P37	Input	Pins P35–P37 are 3-bit input port.

Table 7.2 PIN DESCRIPTION (continued)

Pin	Name	Input/ Output	Functions
P50/HSYNC	Input P5	Input	Port P5 is a 2-bit input port.
P51/VSYNC	Horizontal synchronous signal	Input	P50 pin is also used as a horizontal synchronous signal input HSYNC for OSD.
	Vertical synchronous signal	Input	P51 pin is a vertical synchronous signal input VSYNC for OSD.
P52/B, P53/G, P54/R, P55/OUT	Output P5	output	Pins P52–P55 are 4-bit output port. The output structure is CMOS output.
	OSD output	output	Pins P52–P55 are also used as OSD output pins R, G, B and OUT respectively. The output structure is CMOS output.
FILT	Clock oscillation filter	Input	Connect a capacitor between FILT and Vss.

Notes : Port Pi (i = 0 to 3) has a port Pi direction register that can be used to program each bit for input ("0") or an output ("1"). The pins programmed as "1" in the direction register are output pins. When pins are programmed as "0," they are input pins. When pins are programmed as output pins, the output data is written into the port latch and then output. When data is read from the output pins, the data of the port latch, not the output pin level, is read. This allows a previously output value to be read correctly even if the output LOW voltage has risen due to, for example, a directly-driven light emitting diode. The input pins are in the floating state, so the values of the pins can be read. When data is written to the input pin, it is written only into the port latch, while the pin remains in the floating state.

※ LED drive ports 4 (P24–P27)

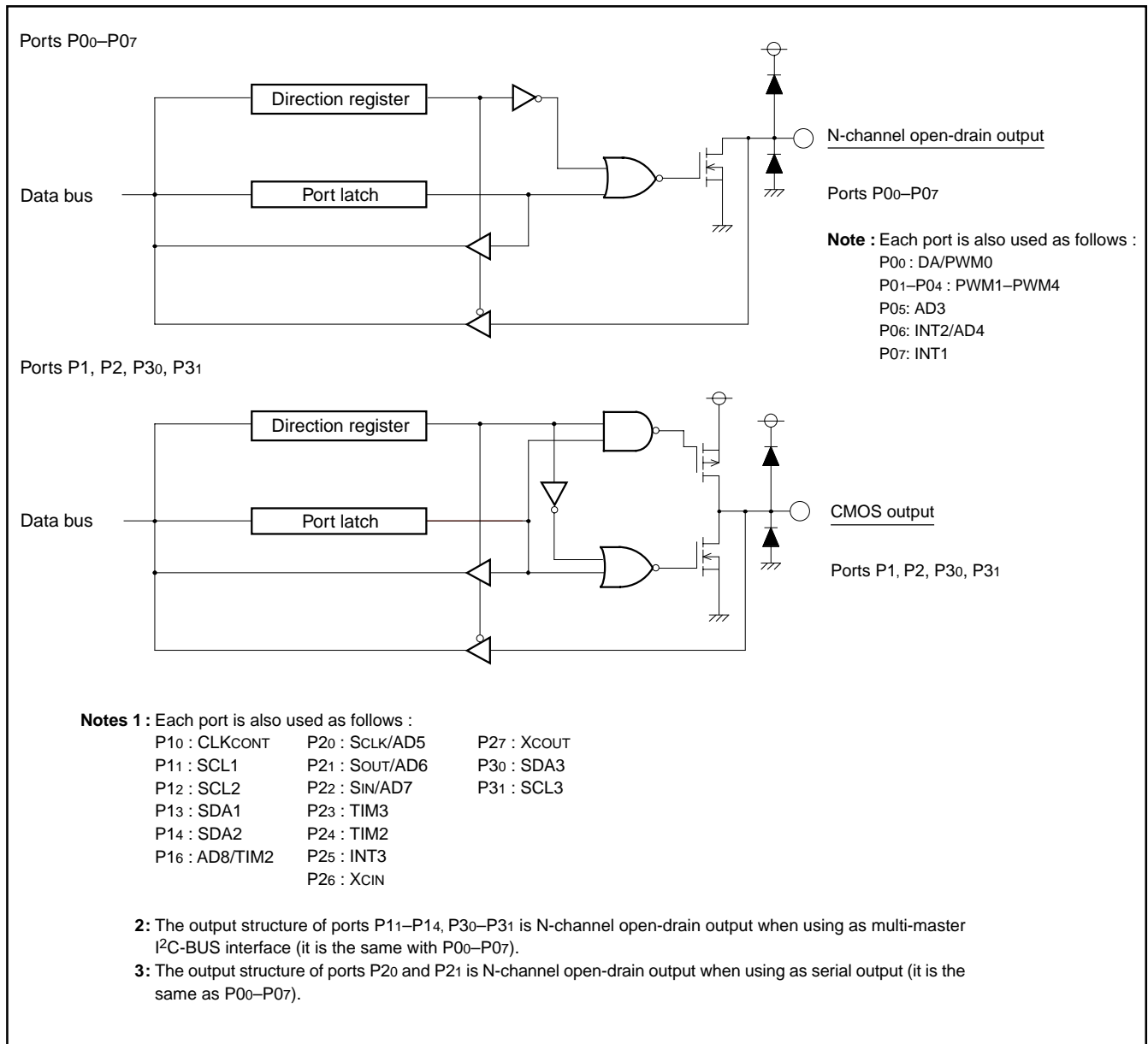

Fig. 7.1 I/O Pin Block Diagram (1)

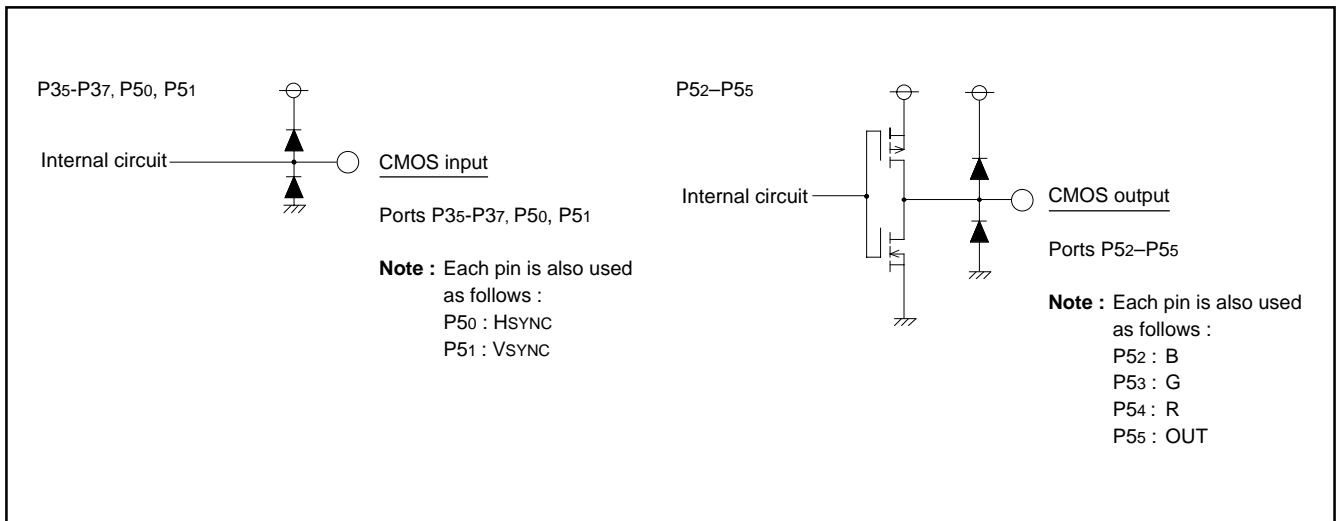

Fig. 7.2 I/O Pin Block Diagram (2)

8. FUNCTION BLOCK DESCRIPTION
8.1 CENTRAL PROCESSING UNIT (CPU)

This microcomputer uses the standard 740 Family instruction set. Refer to the table of 740 Family addressing modes and machine instructions or the SERIES 740 <Software> User's Manual for details on the instruction set.

Availability of 740 Family instructions are as follows:

The FST, SLW instruction cannot be used.

The MUL, DIV, WIT and STP instructions can be used.

8.1.1 CPU Mode Register

The CPU mode register includes a stack page selection bit and internal system clock selection bit. The CPU mode register is allocated at address 00FB16.

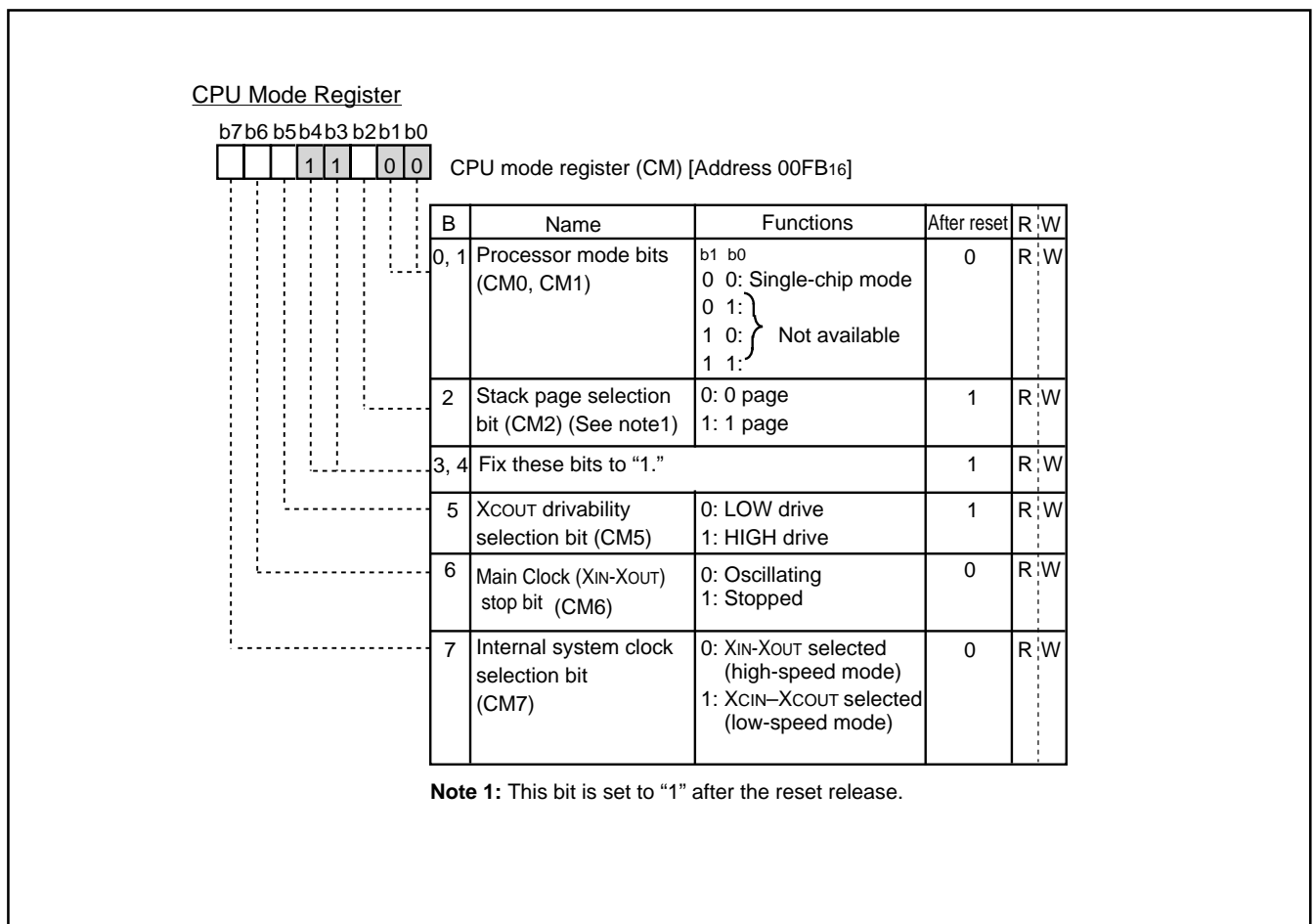

Fig. 8.1.1 CPU Mode Register

8.2 MEMORY

8.2.1 Special Function Register (SFR) Area

The special function register (SFR) area in the zero page includes control registers such as I/O ports and timers.

8.2.2 RAM

RAM is used for data storage and for stack area of subroutine calls and interrupts.

8.2.3 ROM

ROM is used for storing user programs as well as the interrupt vector area.

8.2.4 OSD RAM

RAM used for specifying the character codes and colors for display.

8.2.5 OSD ROM

ROM used for storing character data for display.

8.2.6 Interrupt Vector Area

The interrupt vector area contains reset and interrupt vectors.

8.2.7 Zero Page

The zero page addressing mode can be used to specify memory and register addresses in the zero page area. Access to this area is possible with only 2 bytes in the zero page addressing mode.

8.2.8 Special Page

The special page addressing mode can be used to specify memory addresses in the special page area. Access to this area is possible with only 2 bytes in the special page addressing mode.

8.2.9 ROM Correction Memory (RAM)

This is used as the program area for ROM correction.

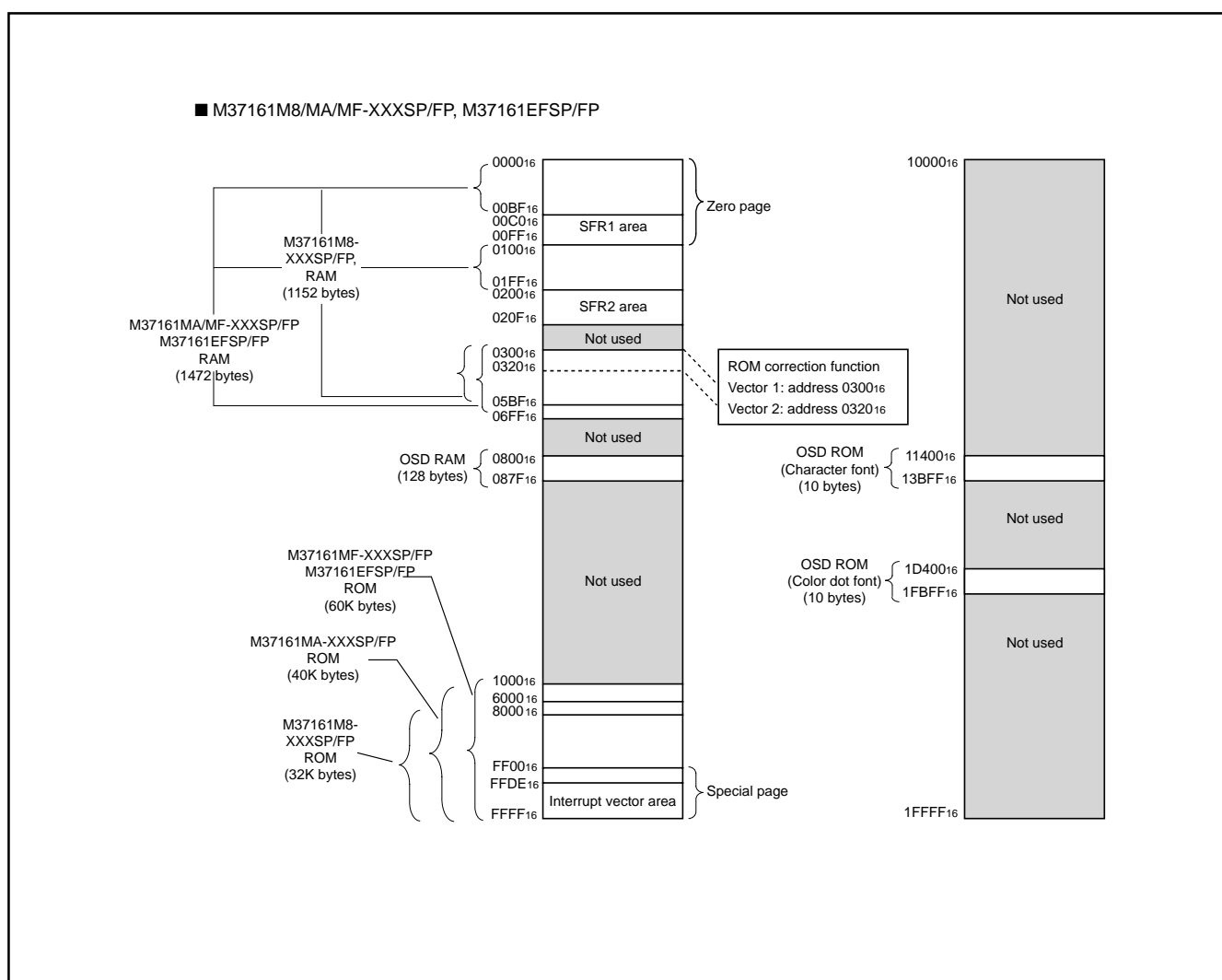

Fig. 8.2.1 Memory Map (M37160M6/M8-XXXSP/FP, M37160EFSP/FP)

■ SFR1 Area (addresses C0₁₆ to DF₁₆)

<Bit allocation>

- : } Function bit
Name
- : No function bit
- 0 : Fix this bit to "0"
(do not write "1")
- 1 : Fix this bit to "1"
(do not write "0")

<State immediately after reset>

- 0 : "0" immediately after reset
- 1 : "1" immediately after reset
- ? : Indeterminate immediately after reset

Address	Register	Bit allocation								State immediately after reset							
		b7						b0		b7						b0	
C0 ₁₆	Port P0(P0)									?							
C1 ₁₆	Port P0 direction register (D0)	00 ₁₆								?							
C2 ₁₆	Port P1(P1)	0								?	?	0	?	?	?	?	?
C3 ₁₆	Port P1 direction register (D1)	0								0	0	1	0	0	0	0	1
C4 ₁₆	Port P2(P2)									?							
C5 ₁₆	Port P2 direction register (D2)	00 ₁₆								?							
C6 ₁₆	Port P3(P3)	P37	P36	P35		BSEL21	BSEL20	P31	P30	?	?	?	0	0	0	?	?
C7 ₁₆	Port P3 direction register (D3)	T2SC	T3SC	1		0	OUTS	P31D	P30D	00 ₁₆							
C8 ₁₆		0	0	0	0	0	0	0	0	?							
C9 ₁₆		0	0	1	1	1	1	1	1	?							
CA ₁₆	Port P5(P5)	0	0					0	0	?							
CB ₁₆	OSD port control register (PF)	0	0	PF5	PF4	PF3	PF2	0	0	0	?	0	0	0	0	0	0
CC ₁₆	Timer return set register (TMS)	TMS	1	1	0	0	0	0	0	00 ₁₆							
CD ₁₆	Clock control register 1 (CC1)	1	0	0	0	0	0	0	CC10	00 ₁₆							
CE ₁₆										?							
CF ₁₆										?							
D0 ₁₆	OSD control register (OC)	OC7	0	0	1	1	OC2	OC1	OC0	00 ₁₆							
D1 ₁₆	Horizontal position register (HP)		HP6	HP5	HP4	HP3	HP2	HP1	HP0	00 ₁₆							
D2 ₁₆	Block control register 1(BC1)	BC17	BC16	BC15	BC14	BC13	BC12	BC11	BC10	?							
D3 ₁₆	Block control register 2(BC2)	BC27	BC26	BC25	BC24	BC23	BC22	BC21	BC20	?							
D4 ₁₆	Vertical position register 1(VP1)	VP17	VP16	VP15	VP14	VP13	VP12	VP11	VP10	?							
D5 ₁₆	Vertical position register 2(VP2)	VP27	VP26	VP25	VP24	VP23	VP22	VP21	VP20	?							
D6 ₁₆	Window register 1(WN1)	WN17	WN16	WN15	WN14	WN13	WN12	WN11	WN10	?							
D7 ₁₆	Window register 2(WN2)	WN27	WN26	WN25	WN24	WN23	WN22	WN21	WN20	?							
D8 ₁₆	I/O polarity control register (PC)	0	PC6	PC5	0	PC3	PC2	PC1	PC0	40 ₁₆							
D9 ₁₆	Raster color register (RC)	RC7	0	0	0	RC3	RC2	RC1	RC0	00 ₁₆							
DA ₁₆	Color dot OSD control register (CDT)							CDT1	CDT0	?							
DB ₁₆	OSD control register 2(OC2)	0	0	0			0	OC21	OC20	0	0	0	?	0	0	0	0
DC ₁₆	Interrupt input polarity control register (RE)						INT3	INT2	INT1	00 ₁₆							
DD ₁₆		00 ₁₆								00 ₁₆							
DE ₁₆		00 ₁₆								00 ₁₆							
DF ₁₆		00 ₁₆								00 ₁₆							

Fig. 8.2.2 Memory Map of Special Function Register 1 (SFR1) (1)

■ SFR1 Area (addresses E0₁₆ to FF₁₆)

<Bit allocation>

: }
Name : } Function bit

: No function bit

0 : Fix this bit to "0"
(do not write "1")

1 : Fix this bit to "1"
(do not write "0")

<State immediately after reset>

0 : "0" immediately after reset

1 : "1" immediately after reset

? : Indeterminate immediately
after reset

Address	Register	Bit allocation								State immediately after reset							
		b7							b0	b7							b0
E0 ₁₆																	?
E1 ₁₆																	?
E2 ₁₆																	?
E3 ₁₆																	?
E4 ₁₆																	?
E5 ₁₆																	?
E6 ₁₆																	?
E7 ₁₆																	?
E8 ₁₆																	?
E9 ₁₆																	?
EA ₁₆	Serial I/O register (SIO)																?
EB ₁₆	Serial I/O mode register (SM)	0	SM6	SM5	0	SM3	SM2	SM1	SM0								00 ₁₆
EC ₁₆	A-D control register 1 (AD1)				ADC14		ADC12	ADC11	ADC10	0	0	0	?	0	0	0	0
ED ₁₆	A-D control register 2 (AD2)		ADC26	ADC25	ADC24	ADC23	ADC22	ADC21	ADC20								00 ₁₆
EE ₁₆	Timer 5 (T5)																07 ₁₆
EF ₁₆	Timer 6 (T6)																FF ₁₆
F0 ₁₆	Timer 1 (T1)																FF ₁₆
F1 ₁₆	Timer 2 (T2)																07 ₁₆
F2 ₁₆	Timer 3 (T3)																FF ₁₆
F3 ₁₆	Timer 4 (T4)																07 ₁₆
F4 ₁₆	Timer mode register 1 (TM1)	TM17	TM16	TM15	TM14	TM13	TM12	TM11	TM10								00 ₁₆
F5 ₁₆	Timer mode register 2 (TM2)	TM27	TM26	TM25	TM24	TM23	TM22	TM21	TM20								00 ₁₆
F6 ₁₆	I ² C data shift register (S0)	D7	D6	D5	D4	D3	D2	D1	D0								?
F7 ₁₆	I ² C address register (S0D)	SAD6	SAD5	SAD4	SAD3	SAD2	SAD1	SAD0	RBW								00 ₁₆
F8 ₁₆	I ² C status register (S1)	MST	TRX	BB	PIN	AL	AAS	AD0	LRB	0	0	0	1	0	0	0	?
F9 ₁₆	I ² C control register (S1D)	BSEL1	BSEL0	10BIT SAD	ALS	ESO	BC2	BC1	BC0								00 ₁₆
FA ₁₆	I ² C clock control register (S2)	ACK	ACK BIT	FAST MODE	CCR4	CCR3	CCR2	CCR1	CCR0								00 ₁₆
FB ₁₆	CPU mode register (CPUM)	CM7	CM6	CM5	1	1	CM2	0	0								3C ₁₆
FC ₁₆	Interrupt request register 1 (IREQ1)		IN3R	VSCR	OSDR	TM4R	TM3R	TM2R	TM1R								00 ₁₆
FD ₁₆	Interrupt request register 2 (IREQ2)	0	TM56R	IICR	IN2R	CKR	S1R	0	IN1R								00 ₁₆
FE ₁₆	Interrupt control register 1 (ICON1)		IN3E	VSC E	OSDE	TM4E	TM3E	TM2E	TM1E								00 ₁₆
FF ₁₆	Interrupt control register 2 (ICON2)	TM56C	TM56E	IICE	IN2E	CKE	S1E	0	IN1E								00 ₁₆

Fig. 8.2.3 Memory Map of Special Function Register 1 (SFR1) (2)

■SFR2 Area (addresses 200₁₆ to 20F₁₆)

<Bit allocation>

- : } Function bit
- : } Function bit
- : No function bit
- : Fix this bit to "0"
(do not write "1")
- : Fix this bit to "1"
(do not write "0")

<State immediately after reset>

- : "0" immediately after reset
- : "1" immediately after reset
- : Indeterminate immediately after reset

Address	Register	Bit allocation								State immediately after reset							
		b7							b0	b7							b0
200 ₁₆	PWM0 register (PWM0)																
201 ₁₆	PWM1 register (PWM1)																
202 ₁₆	PWM2 register (PWM2)																
203 ₁₆	PWM3 register (PWM3)																
204 ₁₆	PWM4 register (PWM4)																
205 ₁₆		00 ₁₆															
206 ₁₆	DA-H register (DAH)																
207 ₁₆	DA-L register (DAL)									0	0	?	?	?	?	?	?
208 ₁₆	PWM mode register 1 (PM1)									?	?	?	0	0	?	?	0
209 ₁₆	PWM mode register 2 (PM2)	0	0	PM25	PM24	PM23	PM22	PM21	PM20	00 ₁₆							
20A ₁₆	ROM correction address 1 (high-order)									00 ₁₆							
20B ₁₆	ROM correction address 1 (low-order)									00 ₁₆							
20C ₁₆	ROM correction address 2 (high-order)									00 ₁₆							
20D ₁₆	ROM correction address 2 (low-order)									00 ₁₆							
20E ₁₆	ROM correction enable register (RCR)							RC1	RC0	00 ₁₆							
20F ₁₆																	
210 ₁₆	Clock frequency set register (CFS)									0	0	0	0	1	1	1	0
211 ₁₆	Clock control register 2(CC2)	0	1	0	0	0	1	0	0	00 ₁₆							
212 ₁₆	Clock control register 3(CC3)	CC37	0	CC35	0	0	0	0	0	00 ₁₆							
213 ₁₆	Test register	0	0	0	0	0	0	0	0	00 ₁₆							

Fig. 8.2.4 Memory Map of Special Function Register 2 (SFR2)

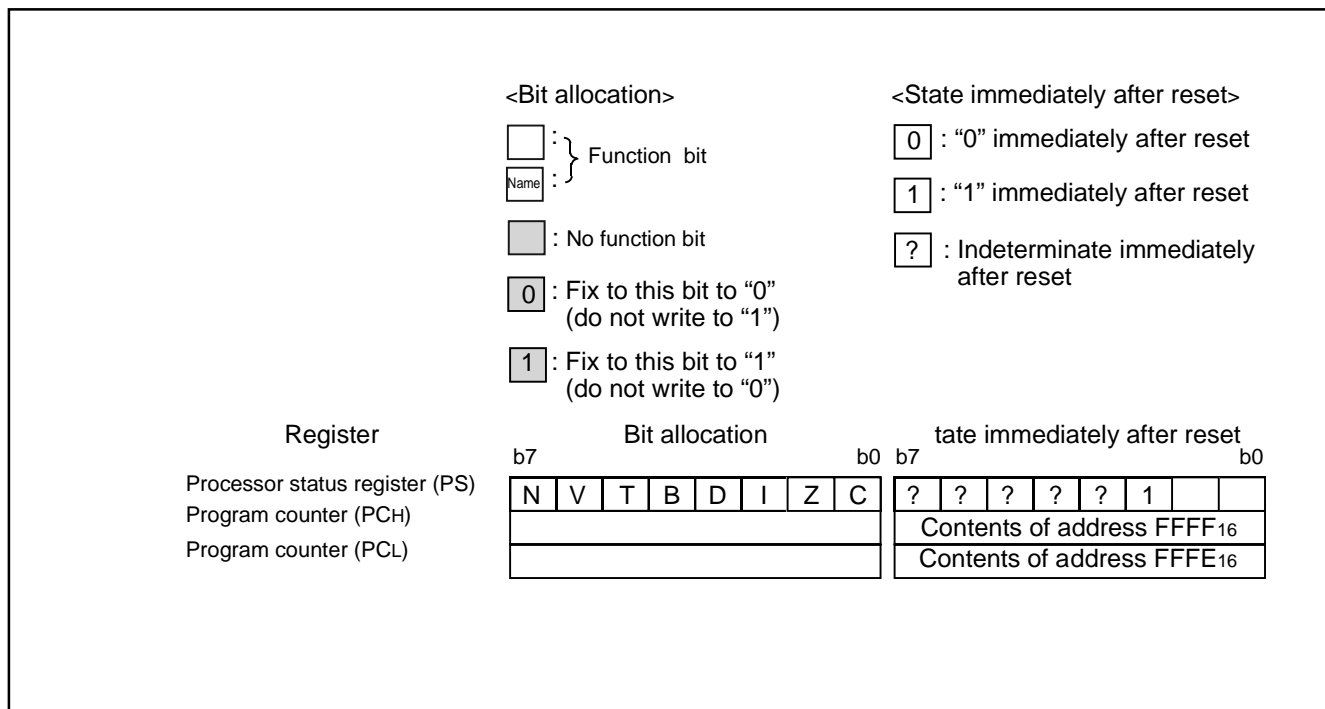

Fig. 8.2.5 Internal State of Processor Status Register and Program Counter at Reset

8.3 INTERRUPTS

Interrupts can be caused by 16 different sources comprising 4 external, 10 internal, 1 software, and reset. Interrupts are vectored interrupts with priorities as shown in Table 8.3.1. Reset is also included in the table because its operation is similar to an interrupt.

When an interrupt is accepted,

- ① The contents of the program counter and processor status register are automatically stored into the stack.
- ② The interrupt disable flag I is set to "1" and the corresponding interrupt request bit is set to "0."
- ③ The jump destination address stored in the vector address enters the program counter.

Other interrupts are disabled when the interrupt disable flag is set to "1."

All interrupts except the BRK instruction interrupt have an interrupt request bit and an interrupt enable bit. The interrupt request bits are in interrupt request registers 1 and 2 and the interrupt enable bits are in interrupt control registers 1 and 2. Figures 8.3.2 to 8.3.6 show the interrupt-related registers.

Interrupts other than the BRK instruction interrupt and reset are accepted when the interrupt enable bit is "1," interrupt request bit is "1," and the interrupt disable flag is "0." The interrupt request bit can be set to "0" by a program, but not set to "1." The interrupt enable bit can be set to "0" and "1" by a program.

Reset is treated as a non-maskable interrupt with the highest priority.

Figure 8.3.1 shows interrupt control.

8.3.1 Interrupt Sources

(1) VSYNC, OSD interrupts

The VSYNC interrupt is an interrupt request synchronized with the vertical sync signal.

The OSD interrupt occurs after character block display to the CRT is completed.

(2) INT1 to INT3 external interrupts

The INT1 to INT3 interrupts are external interrupt inputs, the system detects that the level of a pin changes from LOW to HIGH or from HIGH to LOW, and generates an interrupt request. The input active edge can be selected by bits 3 to 5 of the interrupt input polarity register (address 00DC₁₆): when this bit is "0," a change from LOW to HIGH is detected; when it is "1," a change from HIGH to LOW is detected. Note that both bits are cleared to "0" at reset.

(3) Timers 1 to 4 interrupts

An interrupt is generated by an overflow of timers 1 to 4.

Table 8.3.1 Interrupt Vector Addresses and Priority

Priority	Interrupt Source	Vector Addresses	Remarks
1	Reset	FFFF ₁₆ , FFFE ₁₆	Non-maskable
2	OSD interrupt	FFFD ₁₆ , FFFC ₁₆	
3	INT1 external interrupt	FFFB ₁₆ , FFFA ₁₆	Active edge selectable
4	Serial I/O interrupt	FFF7 ₁₆ , FFF6 ₁₆	
5	Timer 4 interrupt	FFF5 ₁₆ , FFF4 ₁₆	
6	f(XIN)/4096 interrupt	FFF3 ₁₆ , FFF2 ₁₆	
7	VSYNC interrupt	FFF1 ₁₆ , FFF0 ₁₆	
8	Timer 3 interrupt	FFEF ₁₆ , FFEE ₁₆	
9	Timer 2 interrupt	FFED ₁₆ , FFEC ₁₆	
10	Timer 1 interrupt	FFEB ₁₆ , FFEA ₁₆	
11	INT3 external interrupt	FFE9 ₁₆ , FFE8 ₁₆	Active edge selectable
12	INT2 external interrupt	FFE7 ₁₆ , FFE6 ₁₆	Active edge selectable
13	Multi-master I ² C-BUS interface interrupt	FFE5 ₁₆ , FFE4 ₁₆	
14	Timer 5 • 6 interrupt	FFE3 ₁₆ , FFE2 ₁₆	Source switch by software (see note)
15	BRK instruction interrupt	FFDF ₁₆ , FFDE ₁₆	Non-maskable

Note: Switching a source during a program causes an unnecessary interrupt. Therefore, set a source at initializing of program.

(4) Serial I/O interrupt

This is an interrupt request from the clock synchronous serial I/O function.

(5) $f(X_{IN})/4096$ interrupt

The $f(X_{IN})/4096$ interrupt occurs regularly with a $f(X_{IN})/4096$ period. Set bit 0 of the PWM mode register 1 to "0."

(6) Multi-master I²C-BUS interface interrupt

This is an interrupt request related to the multi-master I²C-BUS interface.

(7) Timer 5 • 6 interrupt

An interrupt is generated by an overflow of timer 5 or 6. Their priorities are same, and can be switched by software.

(8) BRK instruction interrupt

This software interrupt has the least significant priority. It does not have a corresponding interrupt enable bit, and it is not affected by the interrupt disable flag I (non-maskable).

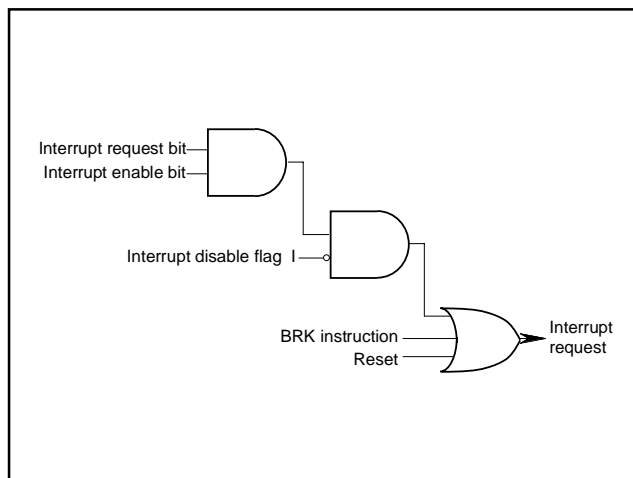

Fig. 8.3.1 Interrupt Control

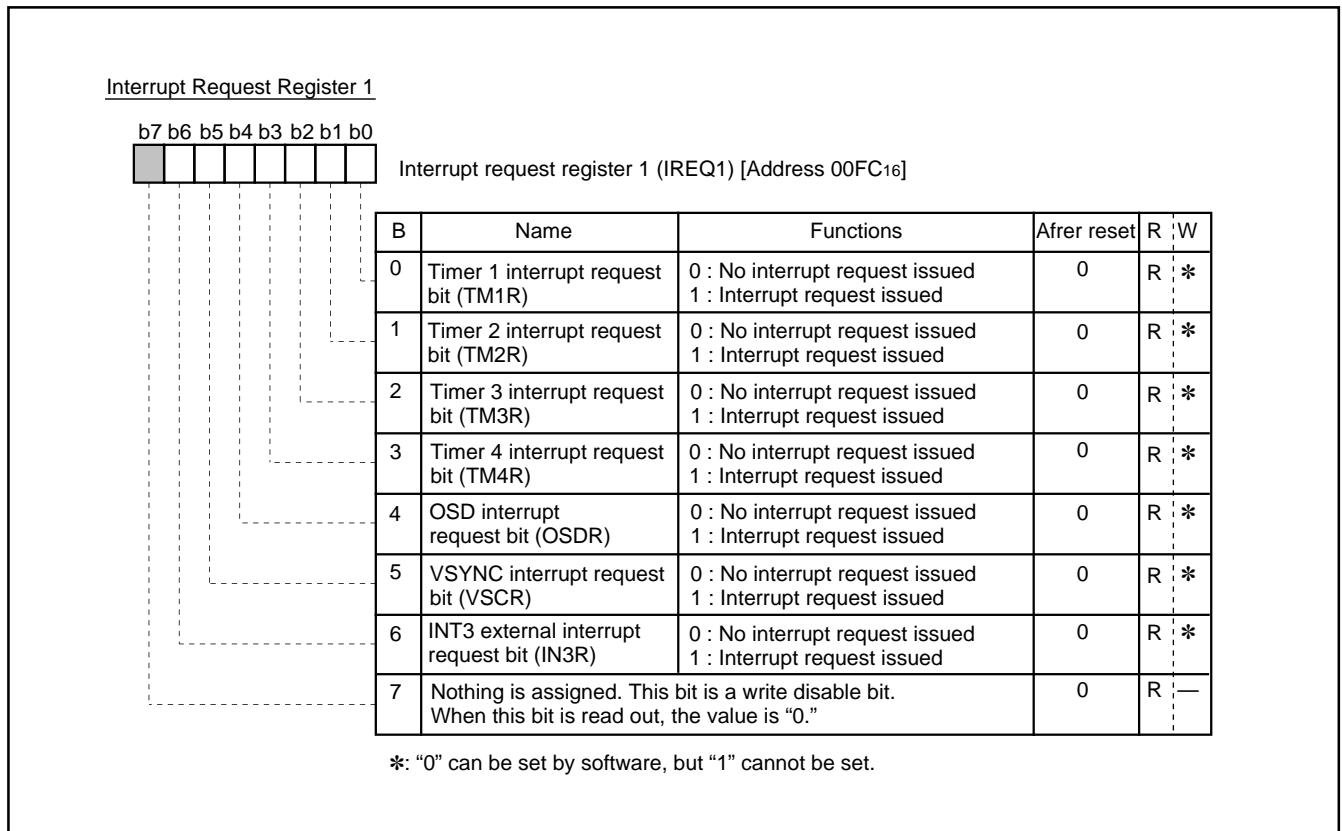

Fig. 8.3.2 Interrupt Request Register 1

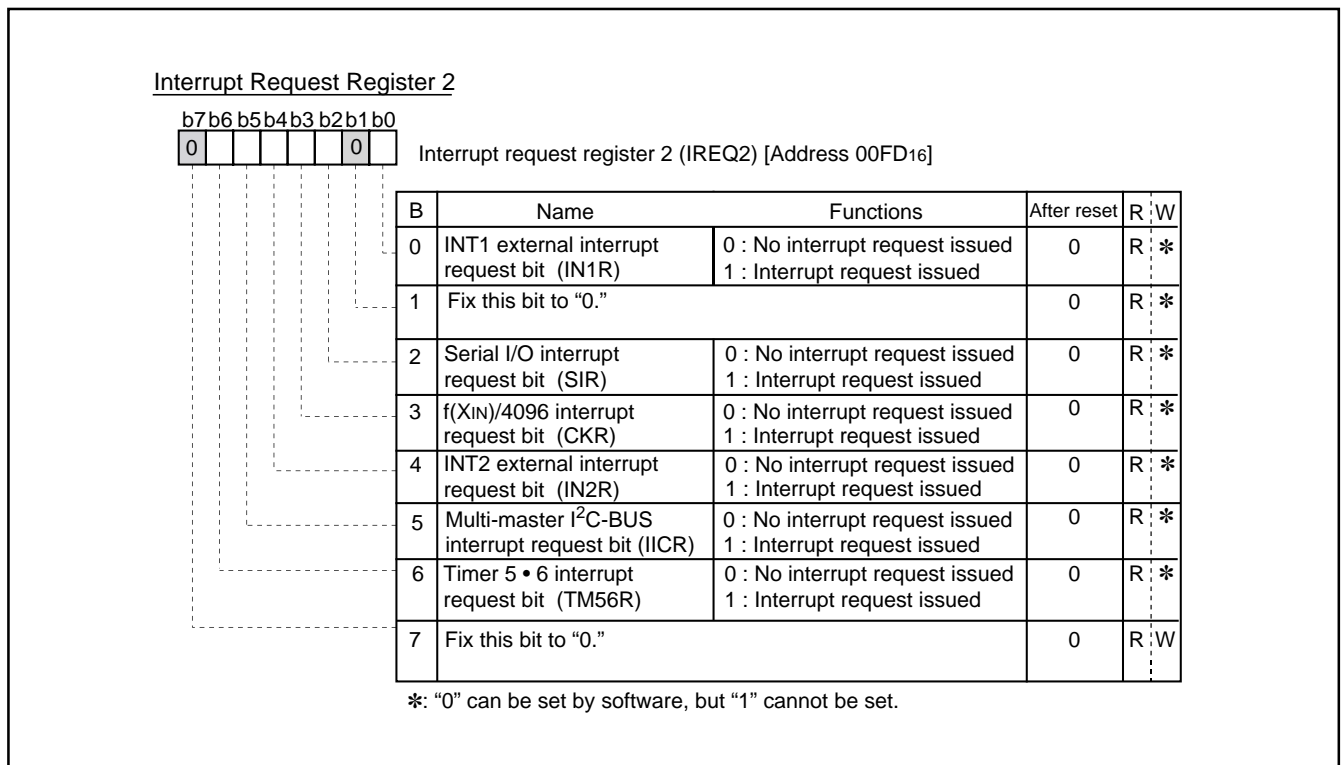
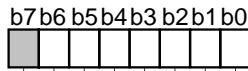

Fig. 8.3.3 Interrupt Request Register 2

Interrupt Control Register 1

Interrupt control register 1 (ICON1) [Address 00FE₁₆]

B	Name	Functions	After reset	R : W
0	Timer 1 interrupt enable bit (TM1E)	0 : Interrupt disabled 1 : Interrupt enabled	0	R : W
1	Timer 2 interrupt enable bit (TM2E)	0 : Interrupt disabled 1 : Interrupt enabled	0	R : W
2	Timer 3 interrupt enable bit (TM3E)	0 : Interrupt disabled 1 : Interrupt enabled	0	R : W
3	Timer 4 interrupt enable bit (TM4E)	0 : Interrupt disabled 1 : Interrupt enabled	0	R : W
4	OSD interrupt enable bit (OSDE)	0 : Interrupt disabled 1 : Interrupt enabled	0	R : W
5	VSYNC interrupt enable bit (VSCE)	0 : Interrupt disabled 1 : Interrupt enabled	0	R : W
6	INT3 external interrupt enable bit (IN3E)	0 : Interrupt disabled 1 : Interrupt enabled	0	R : W
7	Nothing is assigned. This bit is a write disable bit. When this bit is read out, the value is "0."		0	R : —

Fig. 8.3.4 Interrupt Control Register 1

Interrupt Control Register 2

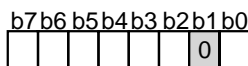
Interrupt control register 2 (ICON2) [Address 00FF₁₆]

B	Name	Functions	After reset	R : W
0	INT1 external interrupt enable bit (IN1E)	0 : Interrupt disabled 1 : Interrupt enabled	0	R : W
1	Fix this bit to "0."		0	R : W
2	Serial I/O interrupt enable bit (SIE)	0 : Interrupt disabled 1 : Interrupt enabled	0	R : W
3	f(XIN)/4096 interrupt enable bit (CKE)	0 : Interrupt disabled 1 : Interrupt enabled	0	R : W
4	INT2 external interrupt enable bit (IN2E)	0 : Interrupt disabled 1 : Interrupt enabled	0	R : W
5	Multi-master I ² C-BUS interface interrupt enable bit (IICE)	0 : Interrupt disabled 1 : Interrupt enabled	0	R : W
6	Timer 5 • 6 interrupt enable bit (TM56E)	0 : Interrupt disabled 1 : Interrupt enabled	0	R : W
7	Timer 5 • 6 interrupt switch bit (TM56C)	0 : Timer 5 1 : Timer 6	0	R : W

Fig. 8.3.5 Interrupt Control Register 2

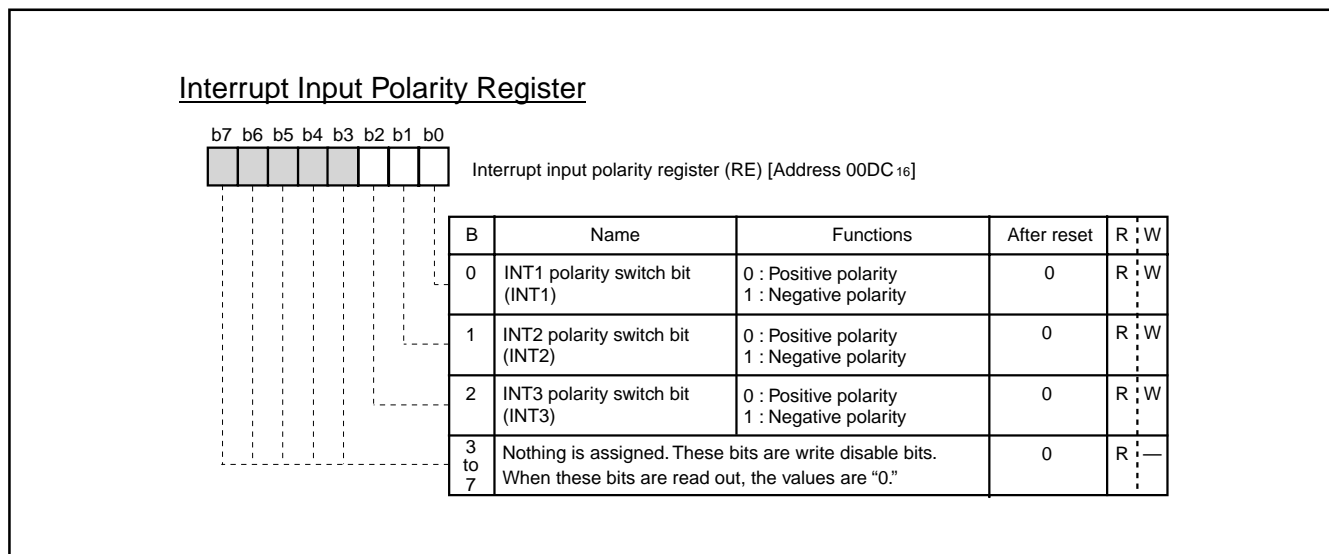

Fig. 8.3.6 Interrupt Input Polarity Register

8.4 TIMERS

This microcomputer has 6 timers: timer 1, timer 2, timer 3, timer 4, timer 5, and timer 6. All timers are 8-bit timers with the 8-bit timer latch. The timer block diagram is shown in Figure 8.4.3.

All of the timers count down and their divide ratio is $1/(n+1)$, where n is the value of timer latch. By writing a count value to the corresponding timer latch (addresses 00F0₁₆ to 00F3₁₆: timers 1 to 4, addresses 00EE₁₆ and 00EF₁₆: timers 5 and 6), the value is also set to a timer, simultaneously.

The count value is decremented by 1. The timer interrupt request bit is set to "1" by a timer overflow at the next count pulse, after the count value reaches "00₁₆".

8.4.1 Timer 1

Timer 1 can select one of the following count sources:

- $f(X_{IN})/16$ or $f(X_{CIN})/16$
- $f(X_{IN})/4096$ or $f(X_{CIN})/4096$
- External clock from the TIM2 pin

The count source of timer 1 is selected by setting bits 5 and 0 of timer mode register 1 (address 00F4₁₆). Either $f(X_{IN})$ or $f(X_{CIN})$ is selected by bit 7 of the CPU mode register.

Timer 1 interrupt request occurs at timer 1 overflow.

8.4.2 Timer 2

Timer 2 can select one of the following count sources:

- $f(X_{IN})/16$ or $f(X_{CIN})/16$
- Timer 1 overflow signal
- External clock from the TIM2 pin

The count source of timer 2 is selected by setting bits 4 and 1 of timer mode register 1 (address 00F4₁₆). Either $f(X_{IN})$ or $f(X_{CIN})$ is selected by bit 7 of the CPU mode register. When timer 1 overflow signal is a count source for the timer 2, the timer 1 functions as an 8-bit prescaler.

Timer 2 interrupt request occurs at timer 2 overflow.

8.4.3 Timer 3

Timer 3 can select one of the following count sources:

- $f(X_{IN})/16$ or $f(X_{CIN})/16$
- $f(X_{CIN})$
- External clock from the TIM3 pin

The count source of timer 3 is selected by setting bit 0 of timer mode register 2 (address 00F5₁₆) and bit 6 at address 00C7₁₆. Either $f(X_{IN})$ or $f(X_{CIN})$ is selected by bit 7 of the CPU mode register.

Timer 3 interrupt request occurs at timer 3 overflow.

8.4.4 Timer 4

Timer 4 can select one of the following count sources:

- $f(X_{IN})/16$ or $f(X_{CIN})/16$
- $f(X_{IN})/2$ or $f(X_{CIN})/2$
- $f(X_{CIN})$

The count source of timer 3 is selected by setting bits 1 and 4 of the timer mode register 2 (address 00F5₁₆). Either $f(X_{IN})$ or $f(X_{CIN})$ is selected by bit 7 of the CPU mode register. When timer 3 overflow signal is a count source for the timer 4, the timer 3 functions as an 8-bit prescaler.

Timer 4 interrupt request occurs at timer 4 overflow.

8.4.5 Timer 5

Timer 5 can select one of the following count sources:

- $f(X_{IN})/16$ or $f(X_{CIN})/16$
- Timer 2 overflow signal
- Timer 4 overflow signal

The count source of timer 3 is selected by setting bit 6 of timer mode register 1 (address 00F4₁₆) and bit 7 of the timer mode register 2 (address 00F5₁₆). When overflow of timer 2 or 4 is a count source for timer 5, either timer 2 or 4 functions as an 8-bit prescaler. Either $f(X_{IN})$ or $f(X_{CIN})$ is selected by bit 7 of the CPU mode register.

Timer 5 interrupt request occurs at timer 5 overflow.

8.4.6 Timer 6

Timer 6 can select one of the following count sources:

- $f(X_{IN})/16$ or $f(X_{CIN})/16$
- Timer 5 overflow signal

The count source of timer 6 is selected by setting bit 7 of the timer mode register 1 (address 00F4₁₆). Either $f(X_{IN})$ or $f(X_{CIN})$ is selected by bit 7 of the CPU mode register. When timer 5 overflow signal is a count source for timer 6, the timer 5 functions as an 8-bit prescaler. Timer 6 interrupt request occurs at timer 6 overflow.

At reset, timers 3 and 4 are connected by hardware and "FF₁₆" is automatically set in timer 3; "07₁₆" in timer 4. The $f(X_{IN})^*/16$ is selected as the timer 3 count source. The internal reset is released by timer 4 overflow in this state and the internal clock is connected.

At execution of the STP instruction, timers 3 and 4 are connected by hardware and "FF₁₆" is automatically set in timer 3; "07₁₆" in timer 4. However, the $f(X_{IN})^*/16$ is not selected as the timer 3 count source. So set both bit 0 of timer mode register 2 (address 00F5₁₆) and bit 6 at address 00C7₁₆ to "0" before the execution of the STP instruction ($f(X_{IN})^*/16$ is selected as timer 3 count source). The internal STP state is released by timer 4 overflow in this state and the internal clock is connected.

As a result of the above procedure, the program can start under a stable clock.

*: When CPU Mode Register bit 7 (CM7) = 1, $f(X_{IN})$ becomes $f(X_{CIN})$.

The timer-related registers is shown in Figures 8.4.1 and 8.4.2.

The input path for the TIM2 pin can be selected between ports P16 or P24. Use Port P3 Direction Register (address 00C7₁₆) bit 7 to select either port.

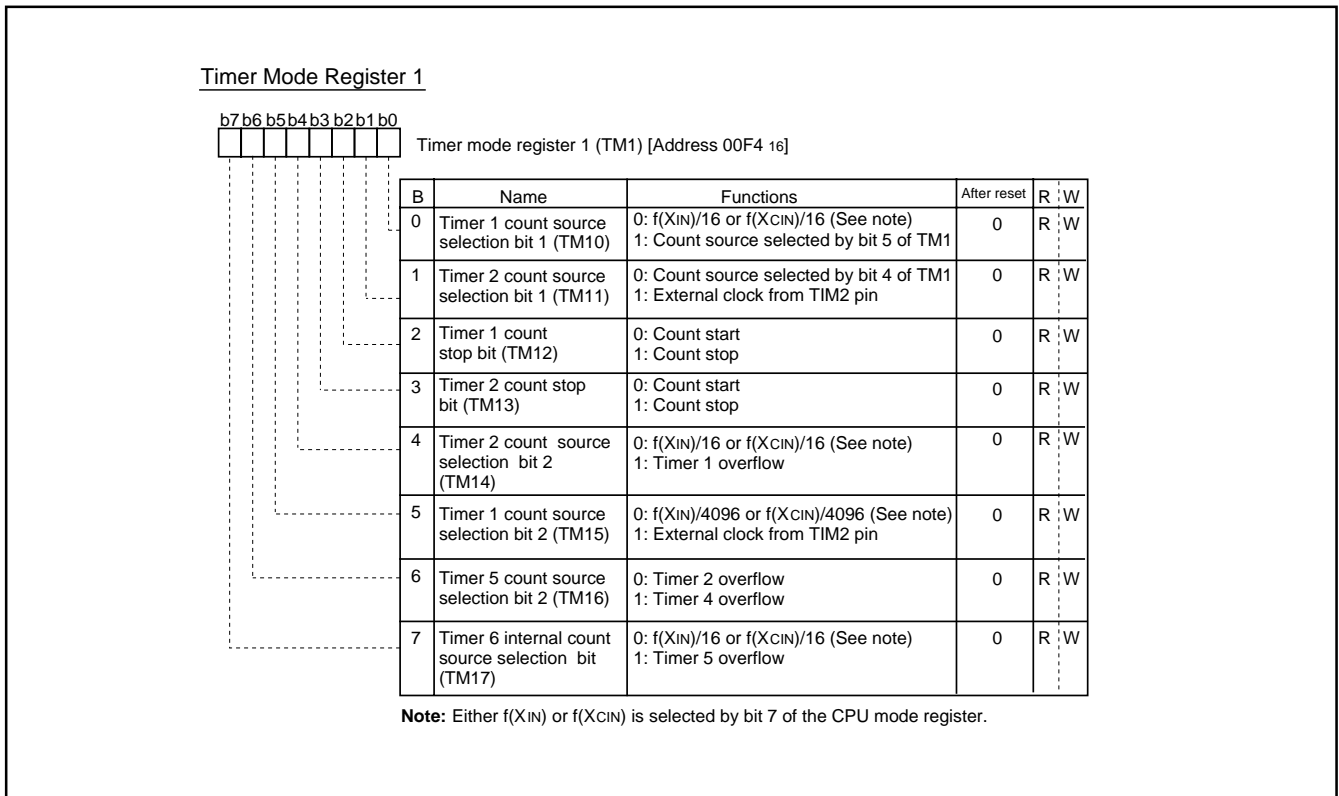

Fig. 8.4.1 Timer Mode Register 1

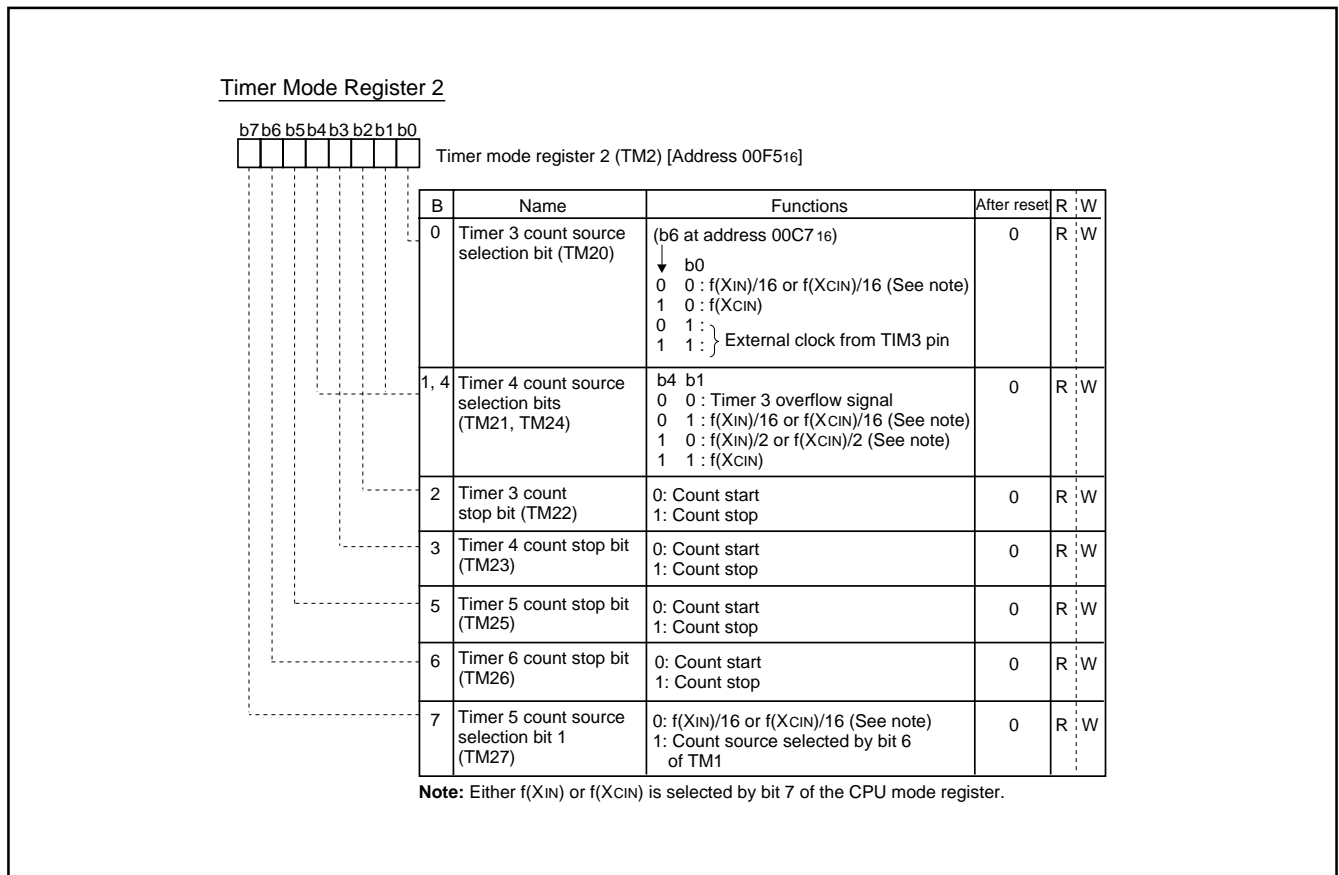
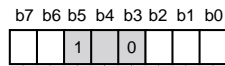

Fig. 8.4.2 Timer Mode Register 2

Port P3 direction register



Port P3 direction register (D3) [Address 00C716]

B	Name	Functions	After reset	R	W
0	Port P3 direction register (See note 1)	0 : Port P3o input 1 : Port P3o output	0	R	W
1		0 : Port P3i input 1 : Port P3i output	0	R	W
2	OUT Output selection bit (OUTS) (See note 2)	0 : 2 value output 1 : 3 value output	0	R	W
3	Fix this bit to "0."		0	R	W
4	Nothing is assigned fix this bits. When this bit are read out, the value are "0."		0	R	-
5	Fix this bit to "1."		0	R	-
6	Timer 3 (T3SC)	Refer to explanation of a timer	0	R	W
7	Timer 2 (T2SC)	0 : P2+ input 1 : P16 input	0	R	W

Notes 1: When using the port as the I²C-BUS interface, set the Port P3 Direction Register to 1.
 2: Use the Clock Control Register 3 (address 021216) bit 5 to select the binary output level of OUT.

Fig. 8.4.3 Port P3 direction register

Timer return setting register

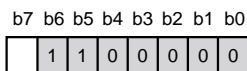

Timer return setting register (TMS) [Address 00CC16]

B	Name	Functions	After reset	R	W
0 to 4	Fix these bits to "0."		0	R	W
5,6	Fix this bit to "1."		0	R	W
7	STOP mode return selection bit (TMS)	0: Timer Count "07FF16" 1: Timer Count Variable	0	R	W

Fig. 8.4.4 Timer return setting register

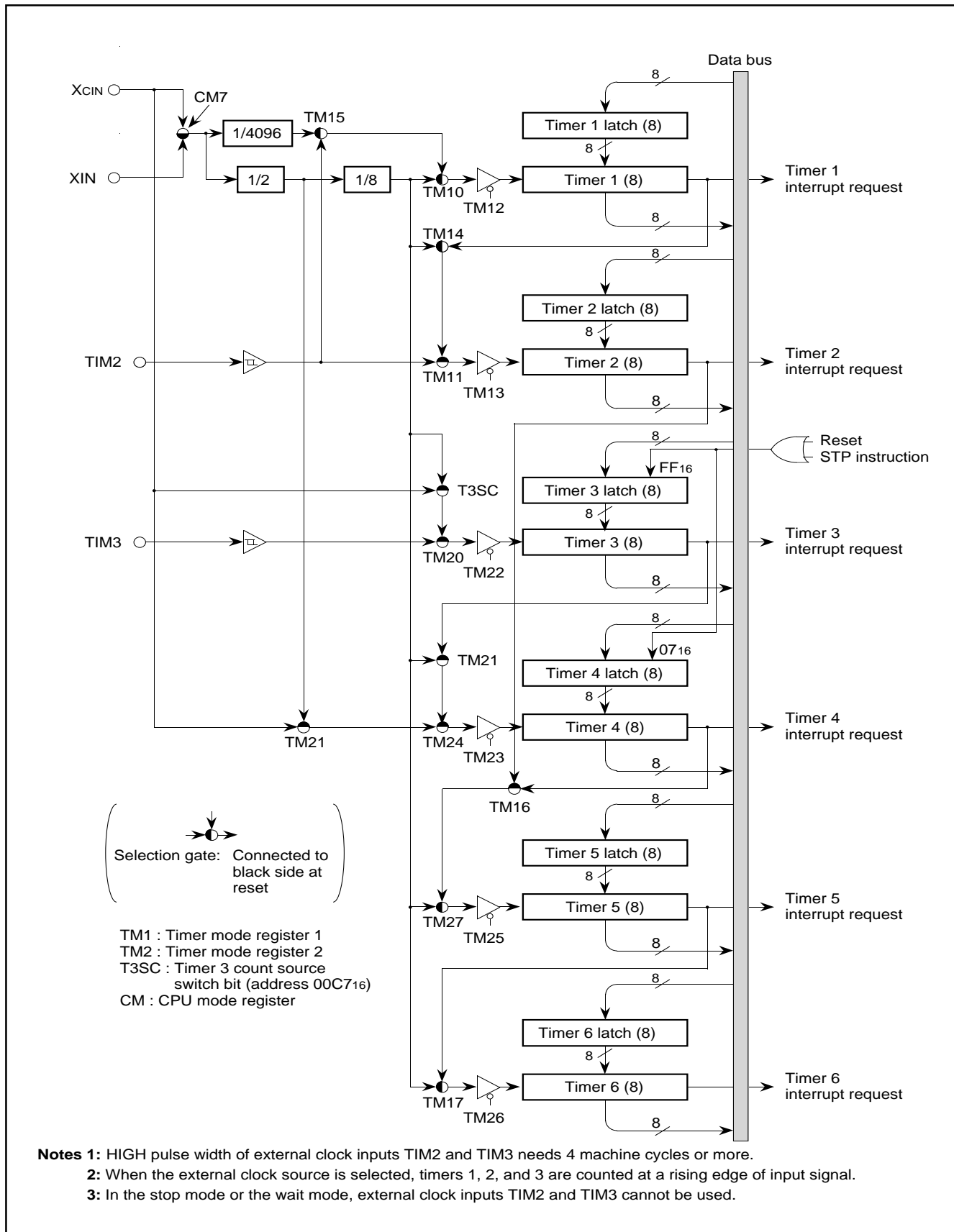

Fig. 8.4.5 Timer Block Diagram

8.5 SERIAL I/O

This microcomputer has a built-in serial I/O which can either transmit or receive 8-bit data serially in the clock synchronous mode.

The serial I/O block diagram is shown in Figure 8.5.1. The synchronous clock I/O pin (SCLK), and data output pin (SOUT) also function as port P4, data input pin (SIN) also functions as port P20–P22.

Bit 3 of the serial I/O mode register (address 00EB16) selects whether the synchronous clock is supplied internally or externally (from the SCLK pin). When an internal clock is selected, bits 1 and 0 select whether f(XIN) or f(XCIN) is divided by 8, 16, 32, or 64. To use the SIN pin for serial I/O, set the corresponding bit of the port P2 direction register (address 00C516) to “0.”

The operation of the serial I/O is described below. The operation of the serial I/O differs depending on the clock source; external clock or internal clock.

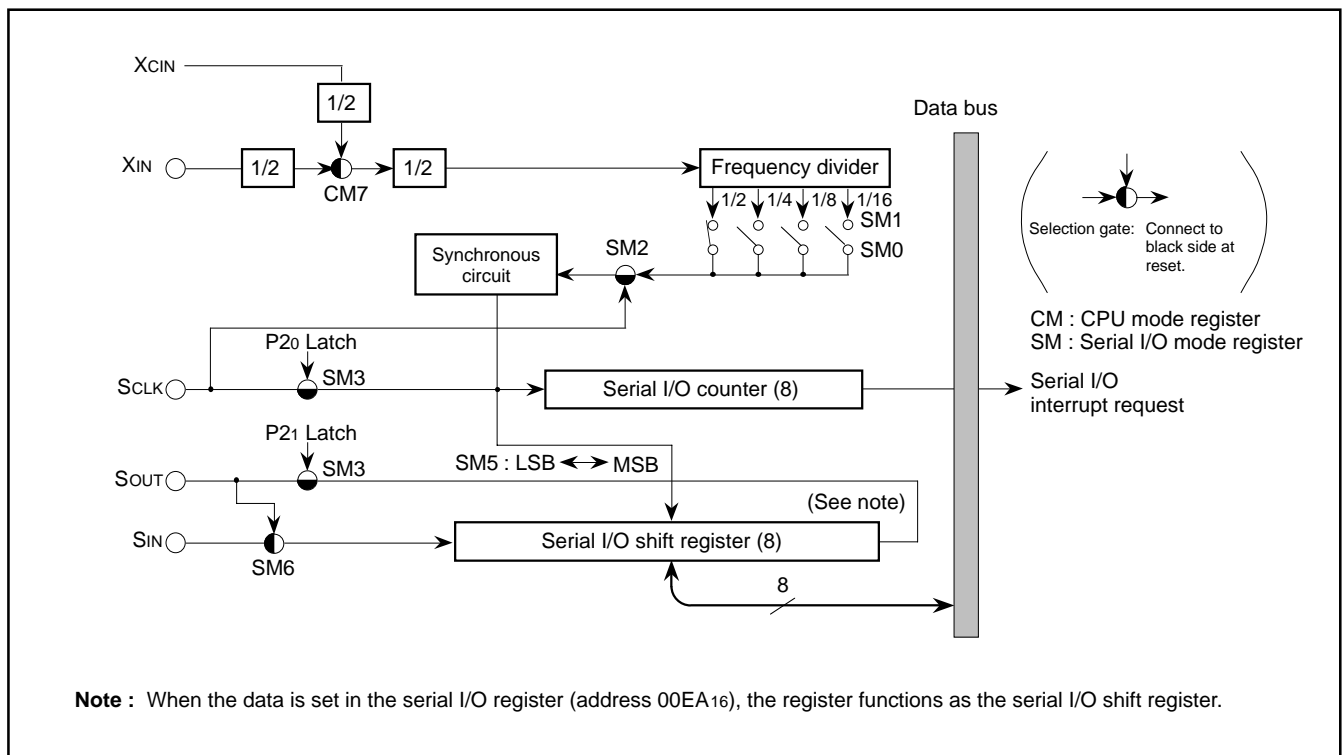

Fig. 8.5.1 Serial I/O Block Diagram

Internal clock : The serial I/O counter is set to "7" during the write cycle into the serial I/O register (address 00EA16), and the transfer clock goes HIGH forcibly. At each falling edge of the transfer clock after the write cycle, serial data is output from the SOUT pin. Transfer direction can be selected by bit 5 of the serial I/O mode register. At each rising edge of the transfer clock, data is input from the SIN pin and data in the serial I/O register is shifted 1 bit. After the transfer clock has counted 8 times, the serial I/O counter becomes "0" and the transfer clock stops at HIGH. At this time the interrupt request bit is set to "1."

External clock : The an external clock is selected as the clock source, the interrupt request is set to "1" after the transfer clock has been counted 8 counts. However, transfer operation does not stop, so the clock should be controlled externally. Use the external clock of 1 MHz or less with a duty cycle of 50%. The serial I/O timing is shown in Figure 8.5.2. When using an external clock for transfer, the external clock must be held at HIGH for initializing the serial I/O counter. When switching between an internal clock and an external clock, do not switch during transfer. Also, be sure to initialize the serial I/O counter after switching.

- Notes 1:** On programming, note that the serial I/O counter is set by writing to the serial I/O register with the bit managing instructions, such as SEB and CLB.
- 2:** When an external clock is used as the synchronous clock, write transmit data to the serial I/O register when the transfer clock input level is HIGH.

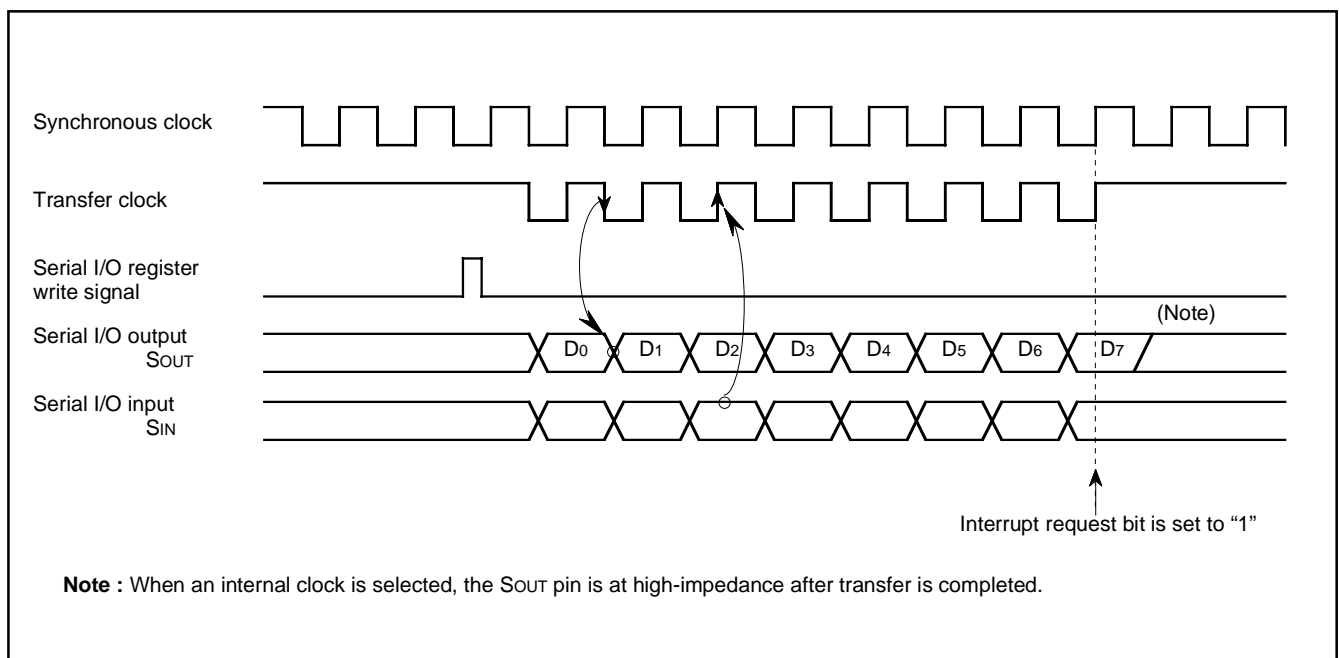
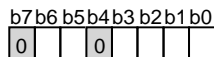

Fig. 8.5.2 Serial I/O Timing (for LSB first)

Serial I/O Mode Register



Serial I/O mode register (SM) [Address 00EB16]

B	Name	Functions	After reset	R	W
0, 1	Internal synchronous clock selection bits (SM0, SM1)	b1 b0 0 0: f(XIN)/8 or f(XCIN)/8 0 1: f(XIN)/16 or f(XCIN)/16 1 0: f(XIN)/32 or f(XCIN)/32 1 1: f(XIN)/64 or f(XCIN)/64	0	R	W
2	Synchronous clock selection bit (SM2)	0: External clock 1: Internal clock	0	R	W
3	Port function selection bit (SM3)	0: P20, P21 1: SCLK, SOUT	0	R	W
4	Fix this bit to "0."		0	R	W
5	Transfer direction selection bit (SM5)	0: LSB first 1: MSB first	0	R	W
6	Transfer clock input pin selection bit (SM6)	0: Input signal from SIN pin 1: Input signal from SOUT pin	0	R	W
7	Fix this bit to "0."		0	R	W

Fig. 8.5.3 Serial I/O Mode Register

8.6 MULTI-MASTER I²C-BUS INTERFACE

The multi-master I²C-BUS interface is a serial communications circuit, conforming to the Philips I²C-BUS data transfer format. This interface, offering both arbitration lost detection and synchronous functions, is useful for multi-master serial communications.

Figure 8.6.1 shows a block diagram of the multi-master I²C-BUS interface and Table 8.6.1 shows multi-master I²C-BUS interface functions.

This multi-master I²C-BUS interface consists of the address register, the data shift register, the clock control register, the control register, the status register and other control circuits.

Table 8.6.1 Multi-master I²C-BUS Interface Functions

Item	Function
Format	In conformity with Philips I ² C-BUS standard: 10-bit addressing format 7-bit addressing format High-speed clock mode Standard clock mode
Communication mode	In conformity with Philips I ² C-BUS standard: Master transmission Master reception Slave transmission Slave reception
SCL clock frequency	16.1 kHz to 400 kHz ($\phi =$ at 4 MHz)

ϕ : System clock = $f(XIN)/2$

Note : We are not responsible for any third party's infringement of patent rights or other rights attributable to the use of the control function (bits 6 and 7 of the I²C control register at address 00F916) for connections between the I²C-BUS interface and ports (SCL1, SCL2, SDA1, SDA2).

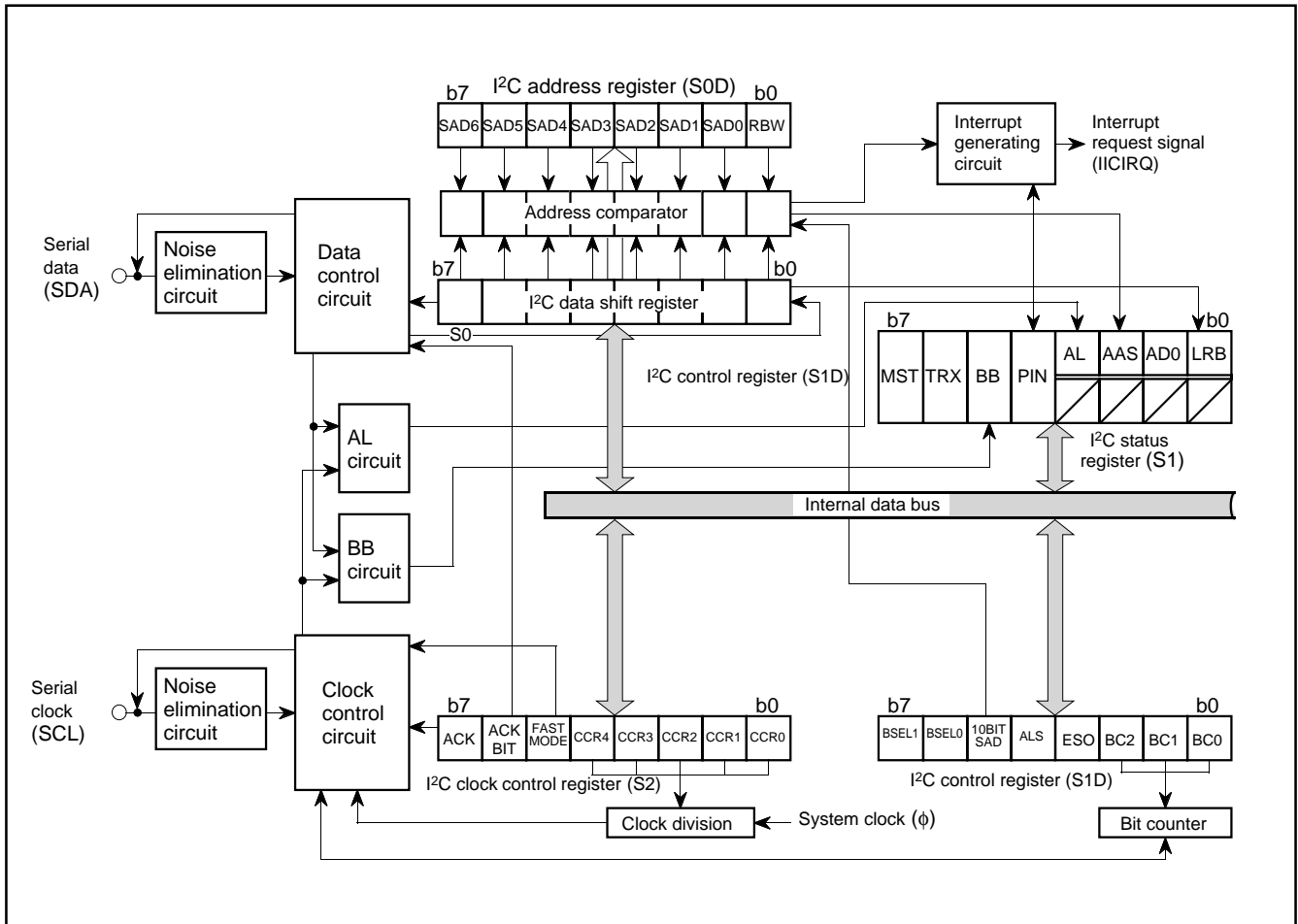

Fig. 8.6.1 Block Diagram of Multi-master I²C-BUS Interface

8.6.1 I²C Data Shift Register

The I²C data shift register (S0 : address 00F6₁₆) is an 8-bit shift register to store receive data and write transmit data.

When transmit data is written into this register, it is transferred to the outside from bit 7 in synchronization with the SCL clock, and each time one-bit data is output, the data of this register are shifted one bit to the left. When data is received, it is input to this register from bit 0 in synchronization with the SCL clock, and each time one-bit data is input, the data of this register are shifted one bit to the left.

The I²C data shift register is in a write enable status only when the ESO bit of the I²C control register (address 00F9₁₆) is "1." The bit counter is reset by a write instruction to the I²C data shift register. When both the ESO bit and the MST bit of the I²C status register (address 00F8₁₆) are "1," the SCL is output by a write instruction to the I²C data shift register. Reading data from the I²C data shift register is always enabled regardless of the ESO bit value.

Note: To write data into the I²C data shift register after setting the MST bit to "0" (slave mode), keep an interval of 8 machine cycles or more.

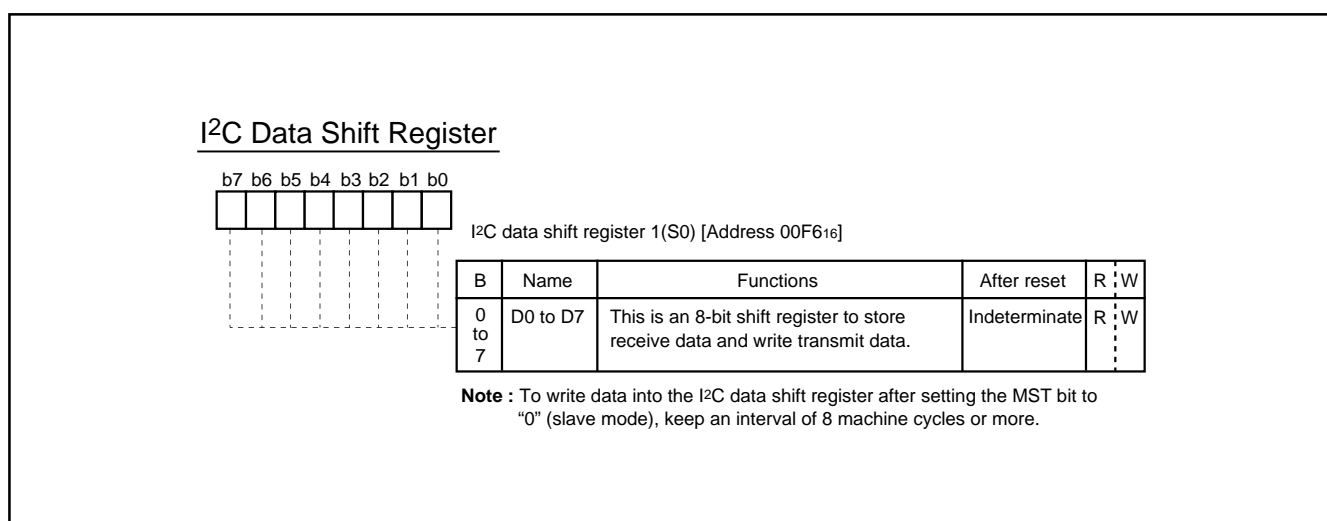

Fig. 8.6.2 I²C Data Shift Register

8.6.2 I²C Address Register

The I²C address register (address 00F7₁₆) consists of a 7-bit slave address and a read/write bit. In the addressing mode, the slave address written in this register is compared with the address data to be received immediately after the START condition is detected.

(1) Bit 0: read/write bit (RBW)

Not used when comparing addresses in the 7-bit addressing mode. In the 10-bit addressing mode, the first address data to be received is compared with the contents (SAD₆ to SAD₀ + RBW) of the I²C address register.

The RBW bit is cleared to "0" automatically when the stop condition is detected.

(2) Bits 1 to 7: slave address (SAD₀–SAD₆)

These bits store slave addresses. Regardless of the 7-bit addressing mode and the 10-bit addressing mode, the address data transmitted from the master is compared with the contents of these bits.

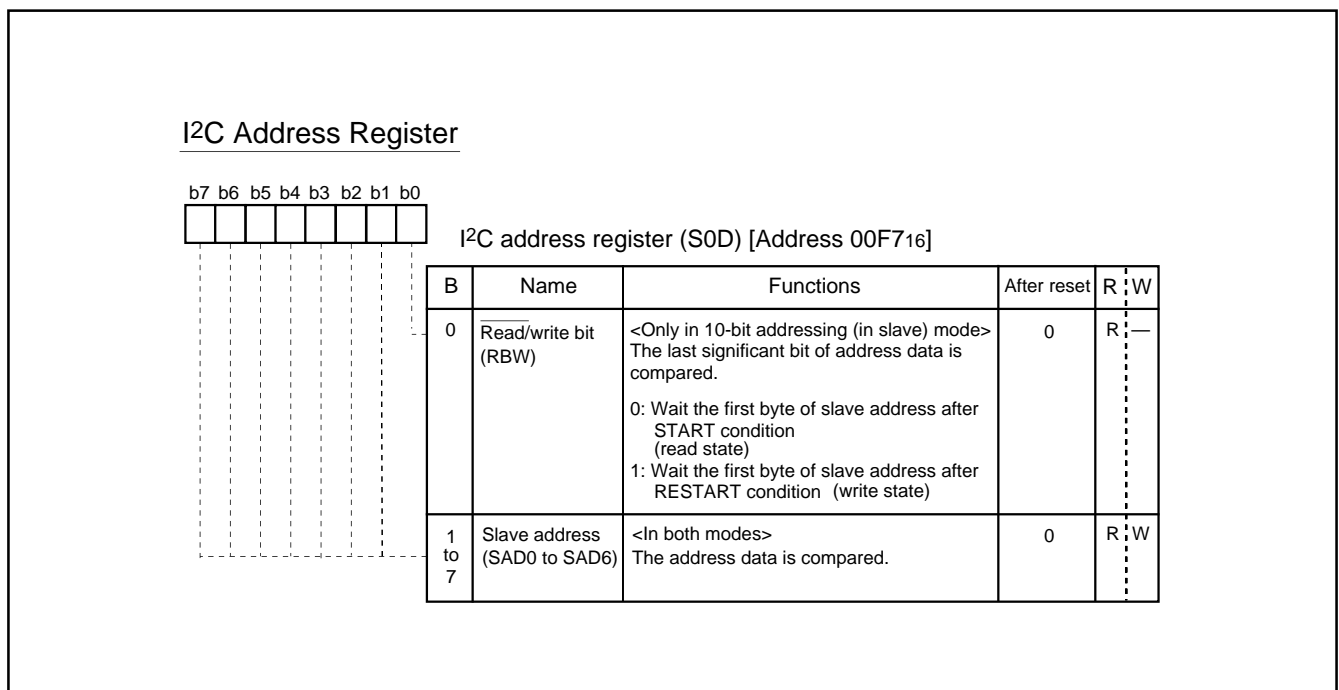

Fig. 8.6.3 I²C Address Register

8.6.3 I²C Clock Control Register

The I²C clock control register (address 00FA16) is used to set ACK control, SCL mode and SCL frequency.

(1) Bits 0 to 4: SCL frequency control bits (CCR0–CCR4)

These bits control the SCL frequency.

(2) Bit 5: SCL mode specification bit (FAST MODE)

This bit specifies the SCL mode. When this bit is set to “0,” the standard clock mode is set. When the bit is set to “1,” the high-speed clock mode is set.

(3) Bit 6: ACK bit (ACK BIT)

This bit sets the SDA status when an ACK clock* is generated. When this bit is set to “0,” the ACK return mode is set and SDA goes to LOW at the occurrence of an ACK clock. When the bit is set to “1,” the ACK non-return mode is set. The SDA is held in the HIGH status at the occurrence of an ACK clock.

However, when the slave address matches the address data in the reception of address data at ACK BIT = “0,” the SDA is automatically goes to LOW (ACK is returned). If there is a mismatch between the slave address and the address data, the SDA is automatically goes to HIGH (ACK is not returned).

*ACK clock: Clock for acknowledgement

(4) Bit 7: ACK clock bit (ACK)

This bit specifies a mode of acknowledgment which is an acknowledgment response of data transmission. When this bit is set to “0,” the no ACK clock mode is set. In this case, no ACK clock occurs after data transmission. When the bit is set to “1,” the ACK clock mode is set and the master generates an ACK clock upon completion of each 1-byte data transmission. The device for transmitting address data and control data releases the SDA at the occurrence of an ACK clock (make SDA HIGH) and receives the ACK bit generated by the data receiving device.

Note: Do not write data into the I²C clock control register during transmission. If data is written during transmission, the I²C clock generator is reset, so that data cannot be transmitted normally.

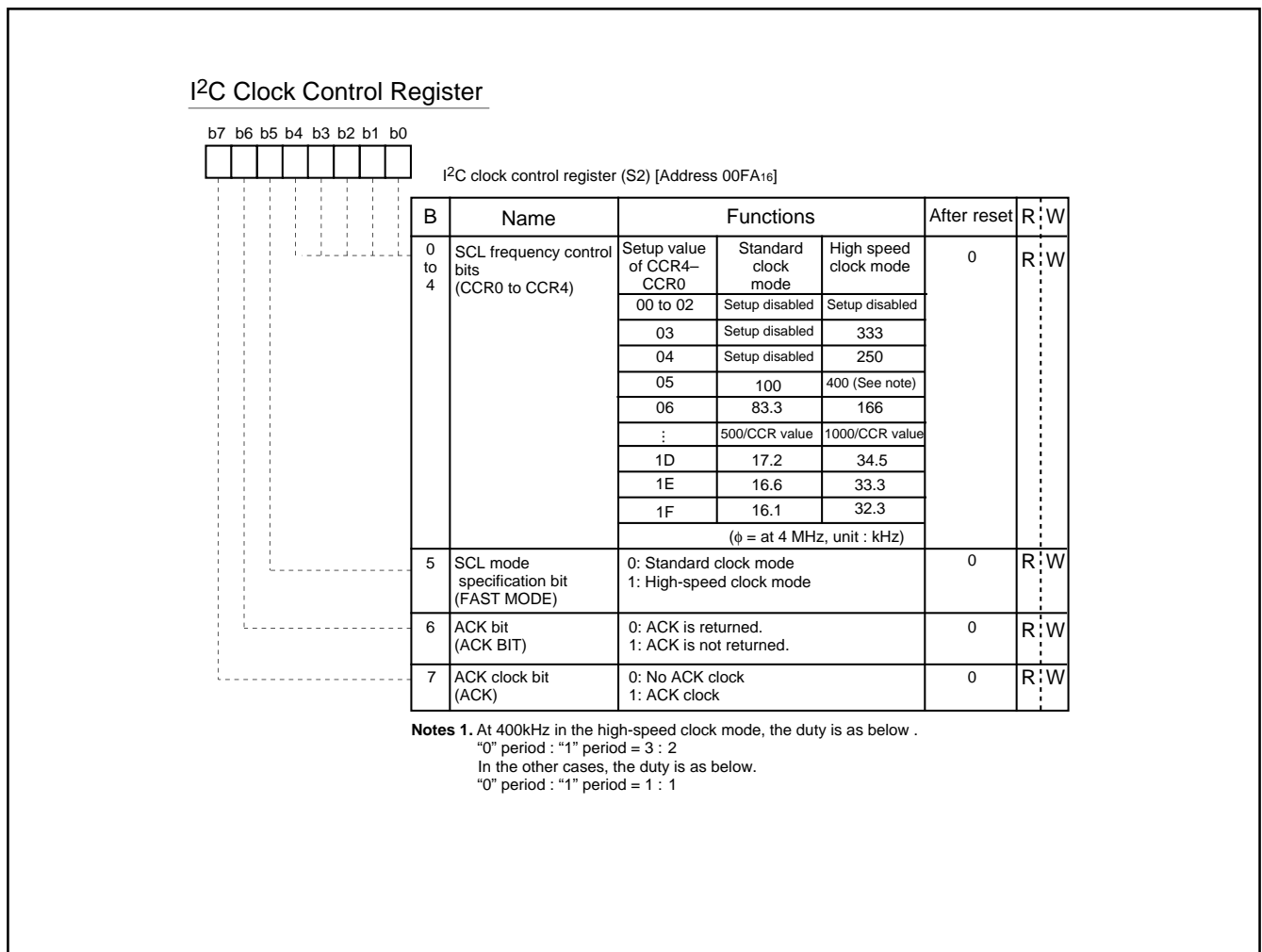

Fig. 8.6.4 I²C Clock Control Register

8.6.4 I²C Control Register

The I²C control register (address 00F9₁₆) controls the data communication format.

(1) Bits 0 to 2: bit counter (BC0–BC2)

These bits decide the number of bits for the next 1-byte data to be transmitted. An interrupt request signal occurs immediately after the number of bits specified with these bits are transmitted.

When a START condition is received, these bits become "000₂" and the address data is always transmitted and received in 8 bits.

(2) Bit 3: I²C interface use enable bit (ESO)

This bit enables usage of the multimaster I²C BUS interface. When this bit is set to "0," interface is in the disabled status, so the SDA and the SCL become high-impedance. When the bit is set to "1," use of the interface is enabled.

When ESO = "0," the following is performed.

- PIN = "1," BB = "0" and AL = "0" are set (they are bits of the I²C status register at address 00F8₁₆).
- Writing data to the I²C data shift register (address 00F6₁₆) is disabled.

(3) Bit 4: data format selection bit (ALS)

This bit decides whether or not to recognize slave addresses. When this bit is set to "0," the addressing format is selected, so that address data is recognized. When a match is found between a slave

address and address data as a result of comparison or when a general call (refer to "8.6.5 I²C Status Register," bit 1) is received, transmission processing can be performed. When this bit is set to "1," the free data format is selected, so that slave addresses are not recognized.

(4) Bit 5: addressing format selection bit (10BIT SAD)

This bit selects a slave address specification format. When this bit is set to "0," the 7-bit addressing format is selected. In this case, only the high-order 7 bits (slave address) of the I²C address register (address 00F7₁₆) are compared with address data. When this bit is set to "1," the 10-bit addressing format is selected and all the bits of the I²C address register are compared with the address data.

(5) Bits 6 and 7: connection control bits between I²C-BUS interface and ports (BSEL0, BSEL1)

These bits control the connection between SCL and ports or SDA and ports (refer to Figure 8.6.5).

Note: To connect with SCL3 and SDA3, set bits 2 and 3 of the port P3 register (00C6₁₆).

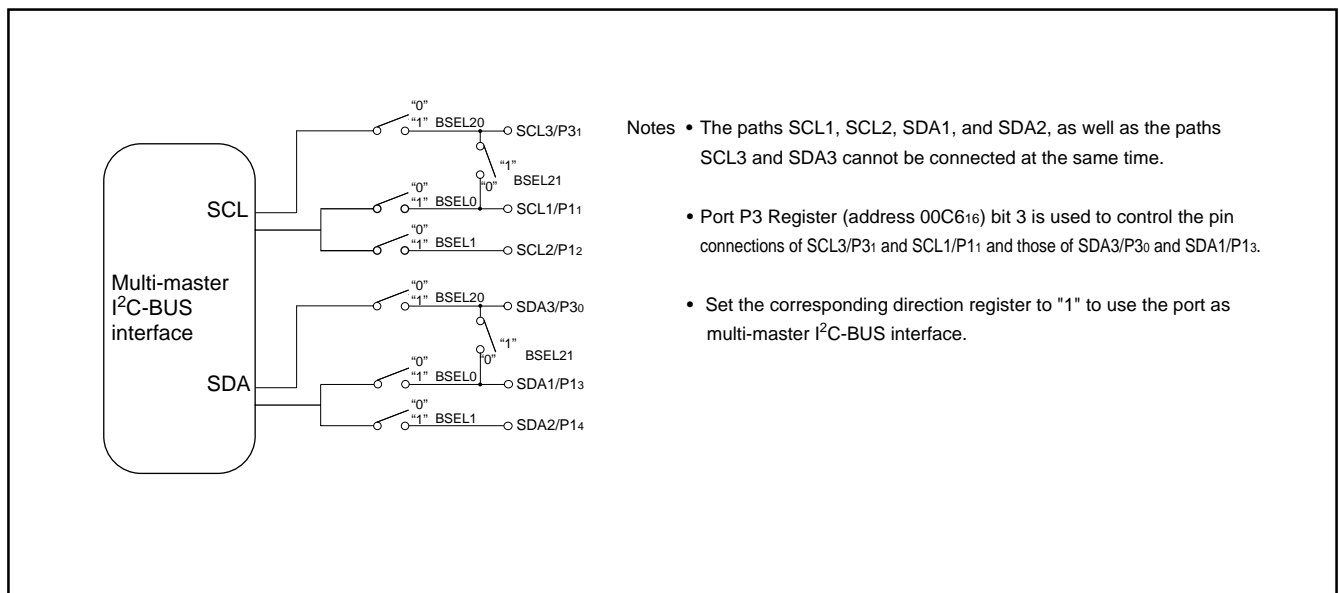

- Notes**
- The paths SCL1, SCL2, SDA1, and SDA2, as well as the paths SCL3 and SDA3 cannot be connected at the same time.
 - Port P3 Register (address 00C6₁₆) bit 3 is used to control the pin connections of SCL3/P3₁ and SCL1/P1₁ and those of SDA3/P3₀ and SDA1/P1₃.
 - Set the corresponding direction register to "1" to use the port as multi-master I²C-BUS interface.

Fig. 8.6.5 Connection Port Control by BSEL0 and BSEL1

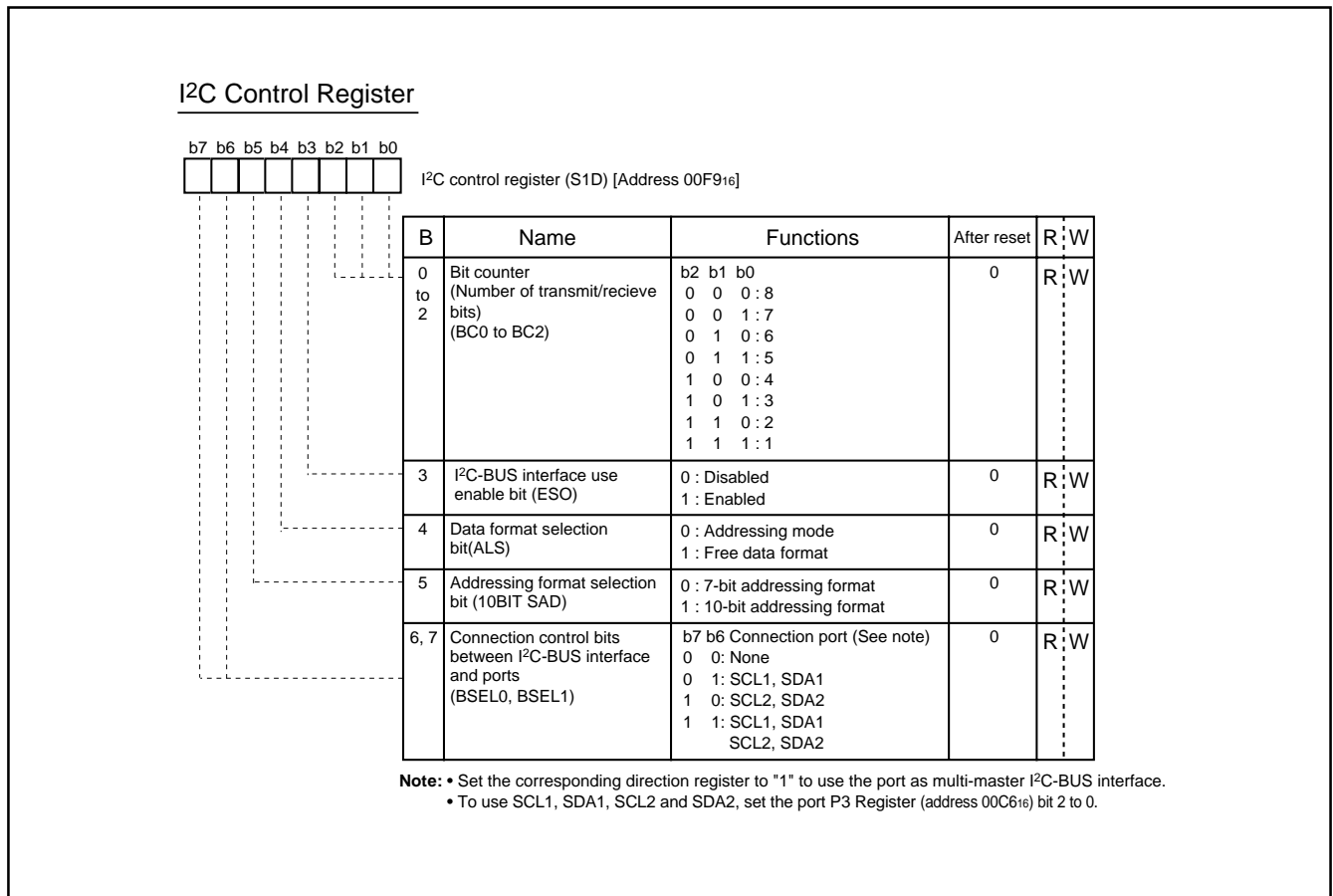

Fig. 8.6.6 I²C Control Register

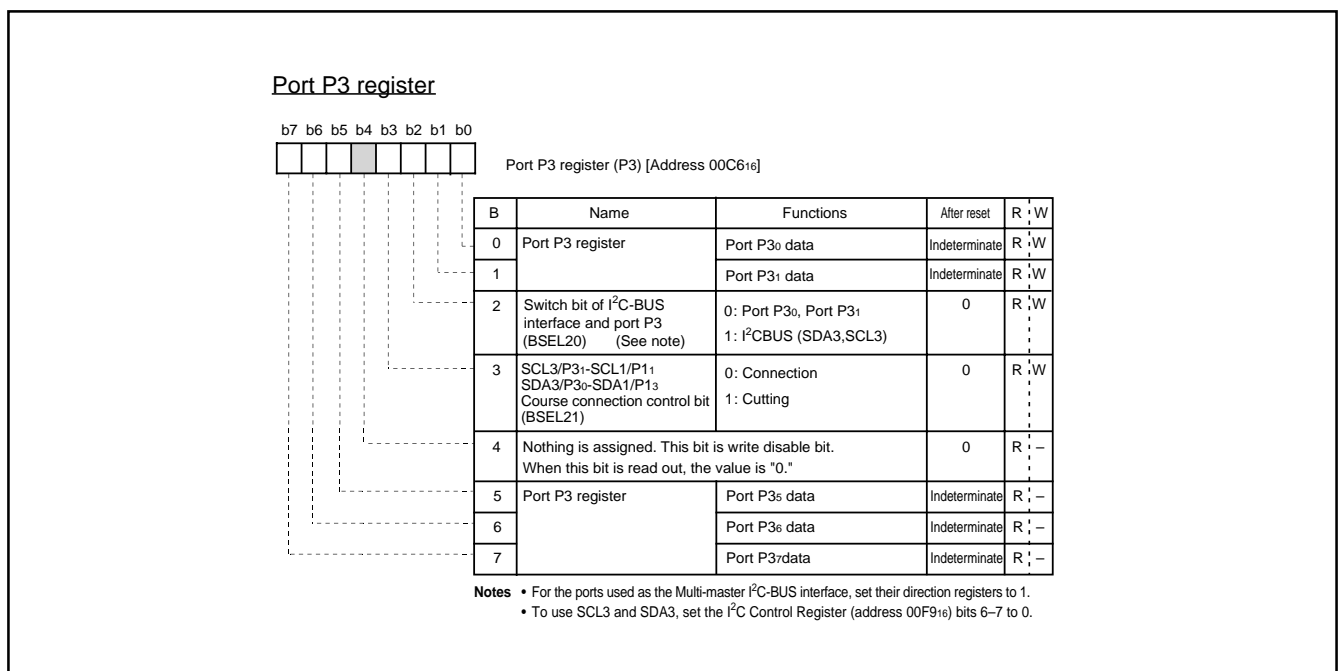

Fig. 8.6.7 Port P3 Register

8.6.5 I²C Status Register

The I²C status register (address 00F816) controls the I²C-BUS interface status. The low-order 4 bits are read-only bits and the high-order 4 bits can be read out and written to.

(1) Bit 0: last receive bit (LRB)

This bit stores the last bit value of received data and can also be used for ACK receive confirmation. If ACK is returned when an ACK clock occurs, the LRB bit is set to "0." If ACK is not returned, this bit is set to "1." Except in the ACK mode, the last bit value of received data is input. The state of this bit is changed from "1" to "0" by executing a write instruction to the I²C data shift register (address 00F616).

(2) Bit 1: general call detecting flag (AD0)

This bit is set to "1" when a general call* whose address data is all "0" is received in the slave mode. By a general call of the master device, every slave device receives control data after the general call. The AD0 bit is set to "0" by detecting the STOP condition or START condition.

*General call: The master transmits the general call address "0016" to all slaves.

(3) Bit 2: slave address comparison flag (AAS)

This flag indicates a comparison result of address data.

- In the slave receive mode, when the 7-bit addressing format is selected, this bit is set to "1" in either of the following conditions.
 - The address data immediately after occurrence of a START condition matches the slave address stored in the high-order 7 bits of the I²C address register (address 00F716).
 - A general call is received.
- In the slave reception mode, when the 10-bit addressing format is selected, this bit is set to "1" in the following condition.
 - When the address data is compared with the I²C address register (8 bits consisting of slave address and RBW), the first bytes match.
- The state of this bit is changed from "1" to "0" by executing a write instruction to the I²C data shift register (address 00F616).

(4) Bit 3: arbitration lost* detecting flag (AL)

In the master transmission mode, when a device other than the microcomputer sets the SDA to "L," arbitration is judged to have been lost, so that this bit is set to "1." At the same time, the TRX bit is set to "0," so that immediately after transmission of the byte whose arbitration was lost is completed, the MST bit is set to "0." When arbitration is lost during slave address transmission, the TRX bit is set to "0" and the reception mode is set. Consequently, it becomes possible to receive and recognize its own slave address transmitted by another master device.

*Arbitration lost: The status in which communication as a master is disabled.

(5) Bit 4: I²C-BUS interface interrupt request bit (PIN)

This bit generates an interrupt request signal. Each time 1-byte data is transmitted, the state of the PIN bit changes from "1" to "0." At the same time, an interrupt request signal is sent to the CPU. The PIN bit is set to "0" in synchronization with a falling edge of the last clock (including the ACK clock) of an internal clock and an interrupt request signal occurs in synchronization with a falling edge of the PIN bit. When the PIN bit is "0," the SCL is kept in the "0" state and clock generation is disabled. Figure 8.6.9 shows an interrupt request signal generating timing chart.

The PIN bit is set to "1" in any one of the following conditions.

- Executing a write instruction to the I²C data shift register (address 00F616).
- When the ESO bit is "0"
- At reset

The conditions in which the PIN bit is set to "0" are shown below:

- Immediately after completion of 1-byte data transmission (including when arbitration lost is detected)
- Immediately after completion of 1-byte data reception
- In the slave reception mode, with ALS = "0" and immediately after completion of slave address or general call address reception
- In the slave reception mode, with ALS = "1" and immediately after completion of address data reception

(6) Bit 5: bus busy flag (BB)

This bit indicates the status of the bus system. When this bit is set to "0," this bus system is not busy and a START condition can be generated. When this bit is set to "1," this bus system is busy and the occurrence of a START condition is disabled by the START condition duplication prevention function (See note).

This flag can be written by software only in the master transmission mode. In the other modes, this bit is set to "1" by detecting a START condition and set to "0" by detecting a STOP condition. When the ESO bit of the I²C control register (address 00F916) is "0" at reset, the BB flag is kept in the "0" state.

(7) Bit 6: communication mode specification bit (transfer direction specification bit: TRX)

This bit decides the direction of transfer for data communication. When this bit is "0," the reception mode is selected and the data of a transmitting device is received. When the bit is "1," the transmission mode is selected and address data and control data are output into the SDA in synchronization with the clock generated on the SCL.

When the ALS bit of the I²C control register (address 00F916) is "0" in the slave reception mode, the TRX bit is set to "1" (transmit) if the least significant bit (R/W bit) of the address data transmitted by the master is "1." When the ALS bit is "0" and the R/W bit is "0," the TRX bit is cleared to "0" (receive).

The TRX bit is cleared to "0" in one of the following conditions.

- When arbitration lost is detected.
- When a STOP condition is detected.
- When occurrence of a START condition is disabled by the START condition duplication prevention function (Note).
- When MST = "0" and a START condition is detected.
- When MST = "0" and ACK non-return is detected.
- At reset

(8) Bit 7: Communication mode specification bit (master/slave specification bit: MST)

This bit is used for master/slave specification in data communications. When this bit is “0,” the slave is specified, so that a START condition and a STOP condition generated by the master are received, and data communication is performed in synchronization with the clock generated by the master. When this bit is “1,” the master is specified and a START condition and a STOP condition are generated, and also the clocks required for data communication are generated on the SCL.

The MST bit is cleared to “0” in any of the following conditions.

- Immediately after completion of 1-byte data transmission when arbitration lost is detected
- When a STOP condition is detected.
- When occurrence of a START condition is disabled by the START condition duplication prevention function (Note).
- At reset

Note: The START condition duplication prevention function disables the START condition generation, bit counter reset, and SCL output, when the following condition is satisfied:
a START condition is set by another master device.

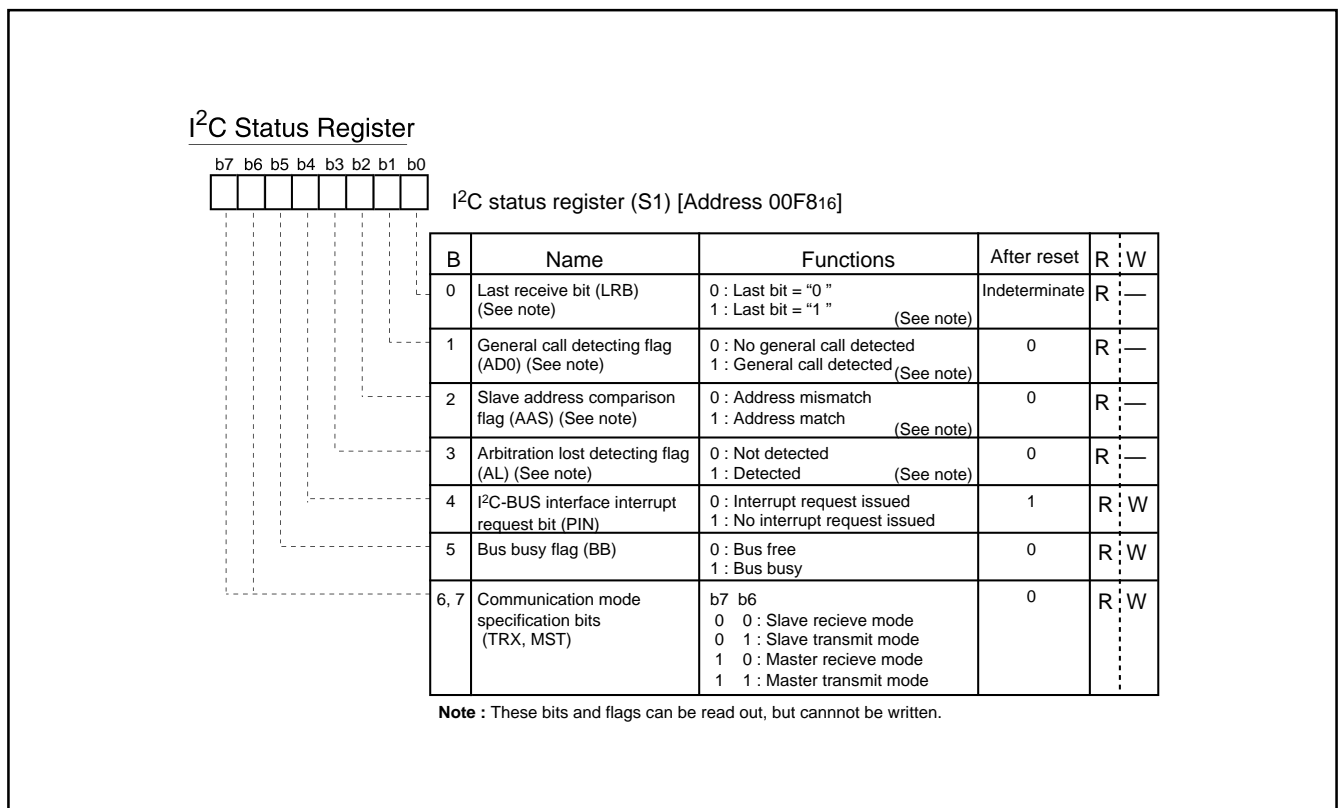

Fig. 8.6.8 I²C Status Register

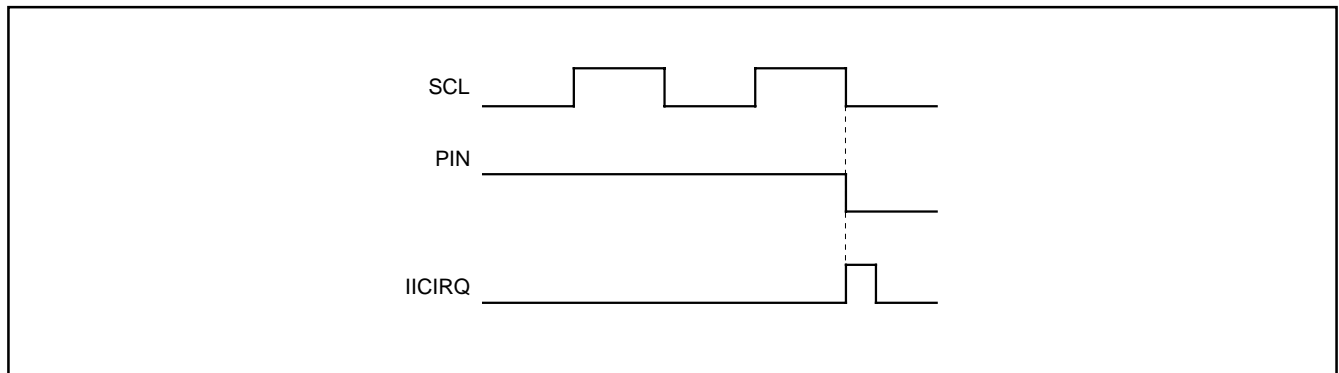

Fig. 8.6.9 Interrupt Request Signal Generation Timing

8.6.6 START Condition Generation Method

When the ESO bit of the I²C control register (address 00F9₁₆) is “1,” execute a write instruction to the I²C status register (address 00F8₁₆) to set the MST, TRX and BB bits to “1.” A START condition will then be generated. After that, the bit counter becomes “000₂” and an SCL is output for 1 byte. The START condition generation timing and BB bit set timing are different in the standard clock mode and the high-speed clock mode. Refer to Figure 8.6.10 for the START condition generation timing diagram, and Table 8.6.2 for the START condition/STOP condition generation timing table.

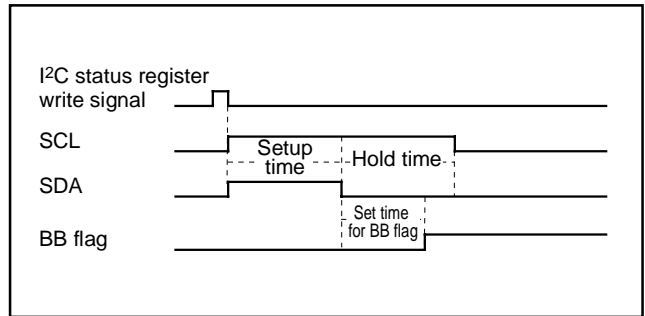

Fig. 8.6.10 START Condition Generation Timing Diagram

8.6.7 STOP Condition Generation Method

When the ESO bit of the I²C control register (address 00F9₁₆) is “1,” execute a write instruction to the I²C status register (address 00F8₁₆) to set the MST bit and the TRX bit to “1” and the BB bit to “0”. A STOP condition will then be generated. The STOP condition generation timing and the BB flag reset timing are different in the standard clock mode and the high-speed clock mode. Refer to Figure 8.6.11 for the STOP condition generation timing diagram, and Table 8.6.2 for the START condition/STOP condition generation timing table.

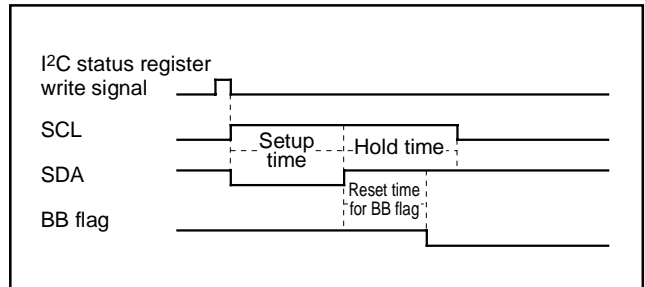

Fig. 8.6.11 STOP Condition Generation Timing Diagram

Table 8.6.2 START Condition/STOP Condition Generation Timing Table

Item	Standard Clock Mode	High-speed Clock Mode
Setup time (START condition)	5.0 μs (20 cycles)	2.5 μs (10 cycles)
Setup time (STOP condition)	4.25 μs (17 cycles)	1.75 μs (7 cycles)
Hold time	5.0 μs (20 cycles)	2.5 μs (10 cycles)
Set/reset time for BB flag	3.0 μs (12 cycles)	1.5 μs (6 cycles)

Note: Absolute time at $\phi = 4$ MHz. The value in parentheses denotes the number of ϕ cycles.

$\phi = 8.86/2$ MHz at FSCIN = 4.43 MHz

8.6.8 START/STOP Condition Detect Conditions

The START/STOP condition detect conditions are shown in Figure 8.6.12 and Table 8.6.3. Only when the 3 conditions of Table 8.6.3 are satisfied, a START/STOP condition can be detected.

Note: When a STOP condition is detected in the slave mode (MST = 0), an interrupt request signal "IICIRQ" is generated to the CPU.

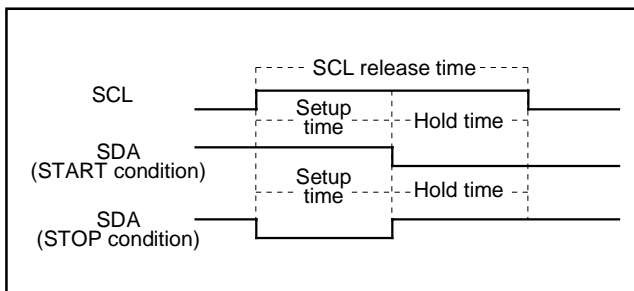

Fig. 8.6.12 START Condition/STOP Condition Detect Timing Diagram

Table 8.6.3 START Condition/STOP Condition Detect Conditions

Standard Clock Mode	High-speed Clock Mode
6.5 μ s (26 cycles) < SCL release time	1.0 μ s (4 cycles) < SCL release time
3.25 μ s (13 cycles) < Setup time	0.5 μ s (2 cycles) < Setup time
3.25 μ s (13 cycles) < Hold time	0.5 μ s (2 cycles) < Hold time

Note: Absolute time at $\phi = 4$ MHz. The value in parentheses denotes the number of ϕ cycles.

8.6.9 Address Data Communication

There are two address data communication formats, namely, 7-bit addressing format and 10-bit addressing format. The respective address communication formats are described below.

(1) 7-bit addressing format

To support the 7-bit addressing format, set the 10BIT SAD bit of the I²C control register (address 00F916) to "0." The first 7-bit address data transmitted from the master is compared with the high-order 7-bit slave address stored in the I²C address register (address 00F716). At the time of this comparison, address comparison of the RBW bit of the I²C address register (address 00F716) is not made. For the data transmission format when the 7-bit addressing format is selected, refer to Figure 8.6.13, (1) and (2).

(2) 10-bit addressing format

To support the 10-bit addressing format, set the 10BIT SAD bit of the I²C control register (address 00F916) to "1." An address comparison is made between the first-byte address data transmitted from the master and the 7-bit slave address stored in the I²C address register (address 00F716). At the time of this comparison, an address comparison is performed between the RBW bit of the I²C address register (address 00F716) and the R/W bit, which is the last bit of the address data transmitted from the master. In the 10-bit addressing mode, the R/W bit not only specifies the direction of communication for control data but is also processed as an address data bit.

When the first-byte address data matches the slave address, the AAS bit of the I²C status register (address 00F816) is set to "1." After the second-byte address data is stored into the I²C data shift register (address 00F616), perform an address comparison between the second-byte data and the slave address by software. When the address data of the 2nd byte matches the slave address, set the RBW bit of the I²C address register (address 00F716) to "1" by software. This processing can match the 7-bit slave address and R/W data, which are received after a RESTART condition is detected, with the value of the I²C address register (address 00F716). For the data transmission format when the 10-bit addressing format is selected, refer to Figure 8.6.13, (3) and (4).

8.6.10 Example of Master Transmission

An example of master transmission in the standard clock mode, at the SCL frequency of 100 kHz with the ACK return mode enabled, is shown below.

- ① Set a slave address in the high-order 7 bits of the I²C address register (address 00F7₁₆) and "0" in the RBW bit.
- ② Set the ACK return mode and SCL = 100 kHz by setting "85₁₆" in the I²C clock control register (address 00FA₁₆).
- ③ Set "10₁₆" in the I²C status register (address 00F8₁₆) and hold the SCL at HIGH.
- ④ Set a communication enable status by setting "48₁₆" in the I²C control register (address 00F9₁₆).
- ⑤ Set the address data of the destination of transmission in the high-order 7 bits of the I²C data shift register (address 00F6₁₆) and set "0" in the least significant bit.
- ⑥ Set "F0₁₆" in the I²C status register (address 00F8₁₆) to generate a START condition. At this time, an SCL for 1 byte and an ACK clock automatically occurs.
- ⑦ Set transmit data in the I²C data shift register (address 00F6₁₆). At this time, an SCL and an ACK clock automatically occurs.
- ⑧ When transmitting control data of more than 1 byte, repeat step ⑦.
- ⑨ Set "D0₁₆" in the I²C status register (address 00F8₁₆). After this, if ACK is not returned or transmission ends, a STOP condition will be generated.

8.6.11 Example of Slave Reception

An example of slave reception in the high-speed clock mode, at the SCL frequency of 400 kHz with the ACK non-return mode enabled while using the addressing format, is shown below.

- ① Set a slave address in the high-order 7 bits of the I²C address register (address 00F7₁₆) and "0" in the RBW bit.
- ② Set the ACK non-return mode and SCL = 400 kHz by setting "25₁₆" in the I²C clock control register (address 00FA₁₆).
- ③ Set "10₁₆" in the I²C status register (address 00F8₁₆) and hold the SCL at HIGH.
- ④ Set a communication enable status by setting "48₁₆" in the I²C control register (address 00F9₁₆).
- ⑤ When a START condition is received, an address comparison is executed.
- ⑥ •When all transmitted address are "0" (general call):
AD0 of the I²C status register (address 00F8₁₆) is set to "1" and an interrupt request signal occurs.
•When the transmitted addresses match the address set in ①:
ASS of the I²C status register (address 00F8₁₆) is set to "1" and an interrupt request signal occurs.
•In the cases other than the above:
AD0 and AAS of the I²C status register (address 00F8₁₆) are set to "0" and no interrupt request signal occurs.
- ⑦ Set dummy data in the I²C data shift register (address 00F6₁₆).
- ⑧ When receiving control data of more than 1 byte, repeat step ⑦.
- ⑨ When a STOP condition is detected, the communication ends.

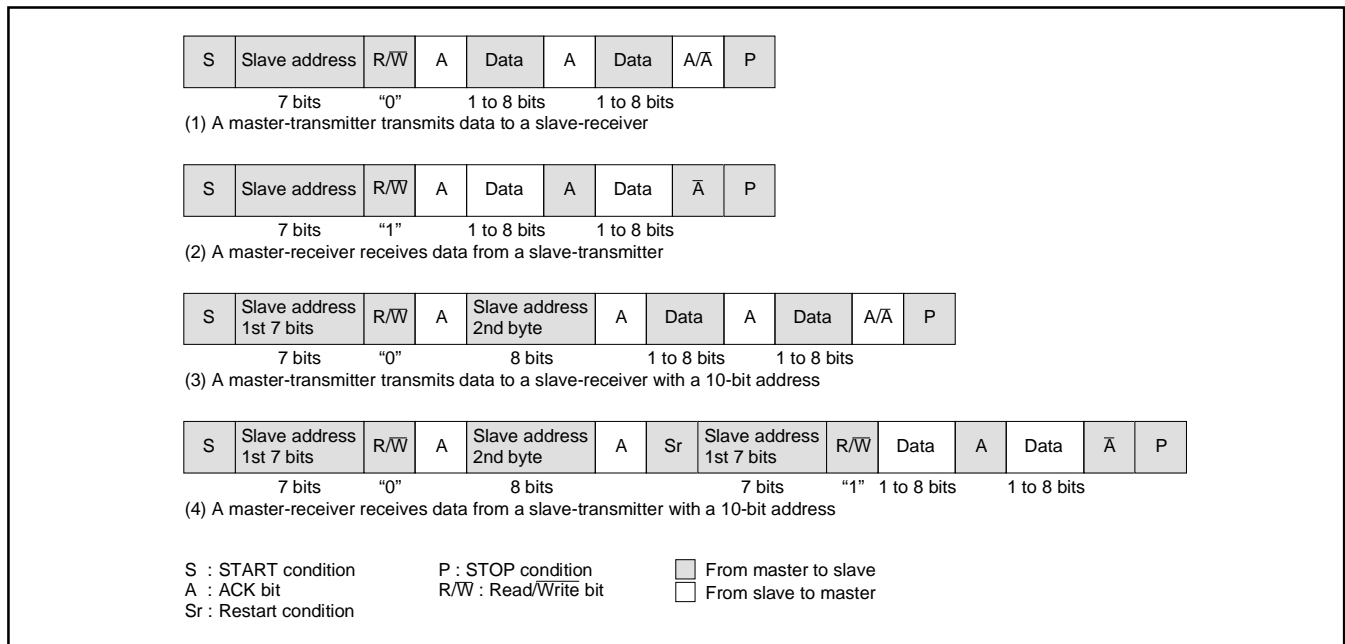

Fig. 8.6.13 Address Data Communication Format

8.6.12 Precautions when using multi-master I²C-BUS interface

(1) Read-modify-write instruction

Precautions for executing the read-modify-write instructions such as SEB and CLB, is executed for each register of the multi-master I²C-BUS interface are described below.

•I²C data shift register (S0)

When executing the read-modify-write instruction for this register during transfer, data may become an arbitrary value.

•I²C address register (S0D)

When the read-modify-write instruction is executed for this register at detection of the STOP condition, data may become an arbitrary value because hardware changes the read/write bit (RBW) at the above timing.

•I²C status register (S1)

Do not execute the read-modify-write instruction for this register because all bits of this register are changed by hardware.

•I²C control register (S1D)

When the read-modify-write instruction is executed for this register at detection of the START condition of the byte transfer, data may become an arbitrary value because hardware changes the bit counter (BC0–BC2) at the above timing.

•I²C clock control register (S2)

The read-modify-write instruction can be executed for this register.

(2) START condition generation procedure using multi-master

① Procedure example (The necessary conditions for the procedure are described in ② to ⑤ below).

```

•
•
LDA    —                (Take out of slave address value)
SEI                    (Interrupt disabled)
BBS    5,S1,BUSBUSY    (BB flag confirmation and branch process)
BUSFREE:
STA    S0                (Write slave address value)
LDM    #$F0, S1         (Trigger START condition generation)
CLI                    (Interrupt enabled)
•
•
BUSBUSY:
CLI                    (Interrupt enabled)
•
•

```

② Use "STA," "STX" or "STY" of the zero page addressing instruction for writing the slave address value to the I²C data shift register.

③ Use "LDM" instruction for setting trigger of START condition generation.

④ Write the slave address value of ② and set trigger of START condition generation as in ③ continuously, as shown in the procedure example.

⑤ Disable interrupts during the following three process steps:

- BB flag confirmation
- Write slave address value
- Trigger of START condition generation

When the condition of the BB flag is bus busy, enable interrupts immediately.

(3) RESTART condition generation procedure

① Procedure example (The necessary conditions for the procedure are described in ② to ⑥ below.)

Execute the following procedure when the PIN bit is "0."

```

      •
      •
LDM  #$00, S1    (Select slave receive mode)
LDA  —           (Take out slave address value)
SEI  —           (Interrupt disabled)
STA  S0          (Write slave address value)
LDM  #$F0, S1    (Trigger RESTART condition generating)
CLI  —           (Interrupt enabled)
      •
      •

```

② Select the slave receive mode when the PIN bit is "0." Do not write "1" to the PIN bit. Neither "0" nor "1" is specified for the writing to the BB bit.

The TRX bit becomes "0" and the SDA pin is released.

③ The SCL pin is released by writing the slave address value to the I²C data shift register. Use "STA," "STX" or "STY" of the zero page addressing instruction for writing.

④ Use "LDM" instruction for setting trigger of RESTART condition generation.

⑤ Write the slave address value of ③ and set trigger of RESTART condition generation of ④ continuously, as shown in the above procedure example.

⑥ Disable interrupts during the following two process steps:

- Write of slave address value
- Trigger RESTART condition generation

(4) STOP condition generation procedure

① Procedure example (The necessary conditions for the procedure are described in ② to ④ below.)

```

      •
      •
SEI  —           (Interrupt disabled)
LDM  #$C0, S1    (Select master transmit mode)
NOP  —           (Set NOP)
LDM  #$D0, S1    (Trigger STOP condition generation)
CLI  —           (Interrupt enabled)
      •
      •

```

② Write "0" to the PIN bit when master transmit mode is selected.

③ Execute "NOP" instruction after master transmit mode is set. Also, set trigger of STOP condition generation within 10 cycles after selecting the master transmit mode.

④ Disable interrupts during the following two process steps:

- Select master transmit mode
- Trigger STOP condition generation

(5) Writing to I²C status register

Do not execute an instruction to set the PIN bit to "1" from "0" and an instruction to set the MST and TRX bits to "0" from "1" simultaneously as it may cause the SCL pin the SDA pin to be released after about one machine cycle. Also, do not execute an instruction to set the MST and TRX bits to "0" from "1" when the PIN bit is "1," as it may cause the same problem.

(6) Process of after STOP condition generation

Do not write data in the I²C data shift register S0 and the I²C status register S1 until the bus busy flag BB becomes "0" after generation the STOP condition in the master mode. Doing so may cause the STOP condition waveform from being generated normally. Reading the registers does not cause the same problem.

8.7 PWM OUTPUT FUNCTION

This microcomputer is equipped with five 8-bit PWMs (PWM0–PWM4). PWM0–PWM4 have the same circuit structure, an 8-bit resolution with minimum resolution bit width of $4\ \mu\text{s}$ and repeat period of $1024\ \mu\text{s}$.

Figure 8.7.1 shows the PWM block diagram. The PWM timing generating circuit applies individual control signals to PWM0–PWM4 using $f(\text{XIN})$ divided by 2 as a reference signal.

8.7.1 Data Setting

When outputting DA, first set the high-order 8 bits to the DA-H register (address 0206₁₆), then the low-order 6 bits to the DA-L register (address 0207₁₆). When outputting PWM0–PWM4, set 8-bit output data to the PWM_i register (i means 0 to 4; addresses 0200₁₆ to 0204₁₆).

8.7.2 Transmitting Data from Register to PWM circuit

Data transfer from the 8-bit PWM register to the 8-bit PWM circuit is executed when writing data to the register.

The signal output from the 8-bit PWM output pin corresponds to the contents of this register.

Also, data transfer from the DA register (addresses 0206₁₆ and 0207₁₆) to the 14-bit PWM circuit is executed at writing data to the DA-L register (address 0207₁₆). Reading from the DA-H register (address 0206₁₆) means reading this transferred data. Accordingly, it is possible to confirm the data being output from the D-A output pin by reading the DA register.

8.7.3 Operating of PWM

The following explains the PWM operation.

• 8bit PWM Operation

First, set bit 0 of PWM mode register 1 (address 0208₁₆) to "0" (at reset, bit 0 is already set to "0" automatically), so that the PWM count source is supplied.

PWM0–PWM4 are also used as pins P00–P04. Set the corresponding bits of the port P0 direction register to "1" (output mode). And select each output polarity by bit 3 of PWM mode register 1 (address 0208₁₆). Then, set bits 4 to 0 of PWM mode register 2 (address 0209₁₆) to "1" (PWM output).

The PWM waveform is output from the PWM output pins by setting these registers.

Figure 8.7.2 shows the 8-bit PWM timing. One cycle (T) is composed of 256 (2^8) segments. 8 kinds of pulses, relative to the weight of each bit (bits 0 to 7), are output inside the circuit during 1 cycle. Refer to Figure 8.7.2 (a). The 8-bit PWM outputs a waveform which is the logical sum (OR) of pulses corresponding to the contents of bits 0 to 7 of the 8-bit PWM register. Several examples are shown in Figure 8.7.2 (b). 256 kinds of output (HIGH area: 0/256 to 255/256) are selected by changing the contents of the PWM register. An entirely HIGH selection cannot be output, i.e. 256/256.

• 14bit PWM operation

As with 8-bit PWM, set the bit 0 of the PWM mode register 1 (address 0208₁₆) to "0" (at reset, bit 0 is already set to "0" automatically), so that the PWM count source is supplied. Pin DA is also used as port P00. Select output mode by setting bit 0 of the port P0 direction register. Next, select the output polarity by bit 4 of the PWM mode register 1. Then, the 14-bit PWM outputs from the D-A output pin by setting bit 5 of the PWM mode register 2 (address 0209₁₆) to "1" (at reset, this bit already set to "0" automatically) to select the DA output.

The output example of the 14-bit PWM is shown in Figure 19. The 14-bit PWM divides the data of the DA latch into the low-order 6 bits and the high-order 8 bits.

The fundamental waveform is determined with the high-order 8-bit data "DH." A "H" level area with a length $\tau \times \text{DH}$ ("H" level area of fundamental waveform) is output every short area of " t " = 256τ = $64\ \mu\text{s}$ (τ is the minimum resolution bit width of $0.25\ \mu\text{s}$). The "H" level area increase interval (t_m) is determined with the low-order 6-bit data "DL." The "H" level area of smaller intervals " t_m " shown in Table.8.7.1 is longer by τ than that of other smaller intervals in PWM repeat period "T" = $64t$. Thus, a rectangular waveform with the different "H" width is output from the D-A pin. Accordingly, the PWM output changes by τ unit pulse width by changing the contents of the DA-H and DA-L registers. A length of entirely "H" output cannot be output, i. e. 256/256.

Table 8.7.1 Relation Between Low-order 6-bit Data and High-level Area Increase Interval

Low-order 6 bits of Data	Area Longer by t Than That of Other t_m ($m = 0$ to 63)
0 0 0 0 0 0	Nothing
0 0 0 0 0 1	$m = 32$
0 0 0 0 1 0	$m = 16, 48$
0 0 0 1 0 0	$m = 8, 24, 40, 56$
0 0 1 0 0 0	$m = 4, 12, 20, 28, 36, 44, 52, 60$
0 1 0 0 0 0	$m = 2, 6, 10, 14, 18, 22, 26, 30, 34, 38, 42, 46, 50, 54, 58, 62$
1 0 0 0 0 0	$m = 1, 3, 5, 7, \dots, 57, 59, 61, 63$

8.7.4 Output after Reset

At reset, the output of ports P00–P04 is in the high-impedance state, and the contents of the PWM register and the PWM circuit are undefined. Note that after reset, the PWM output is undefined until setting the PWM register.

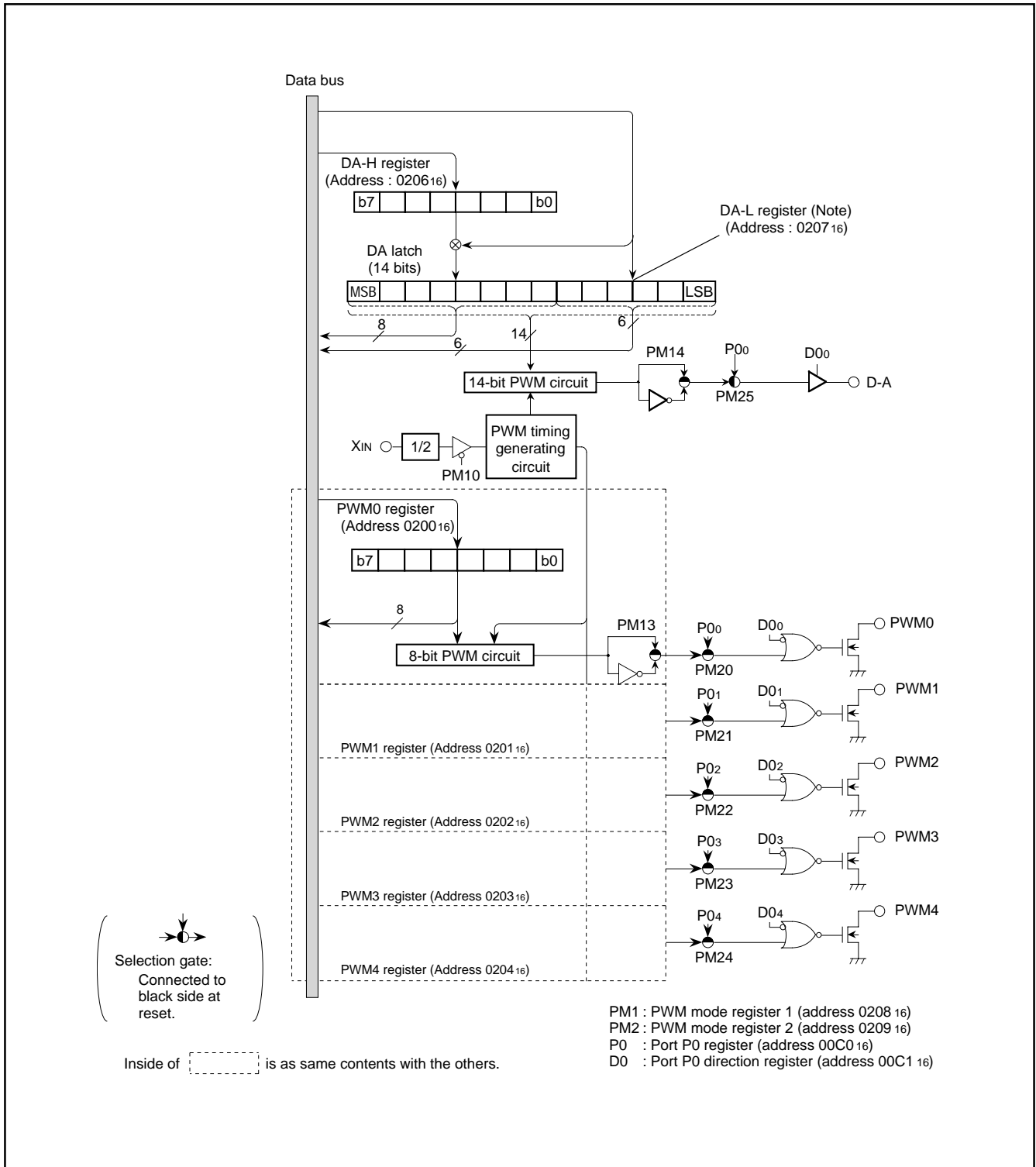

Fig. 8.7.1 PWM Block Diagram

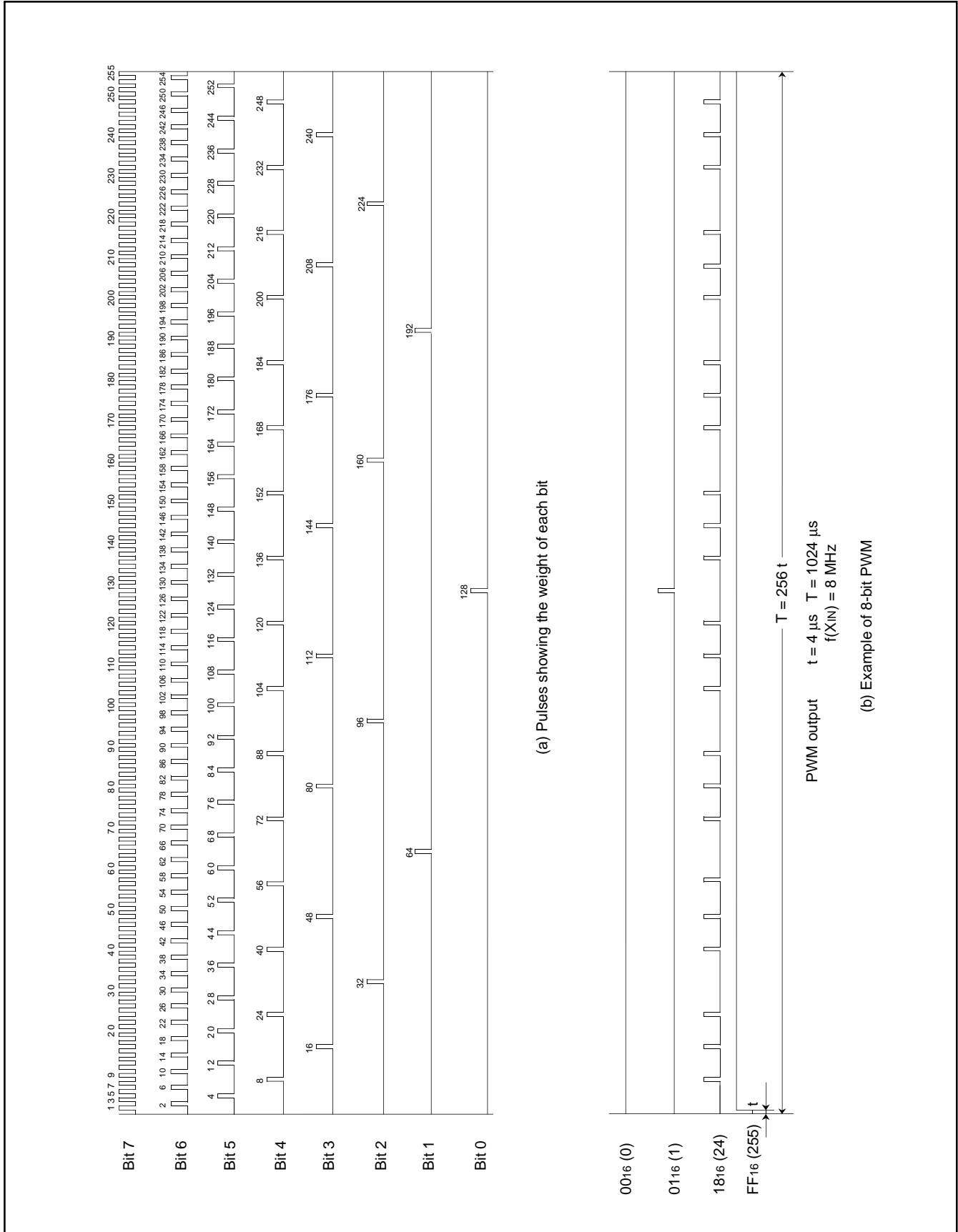

Fig. 8.7.2 PWM Timing

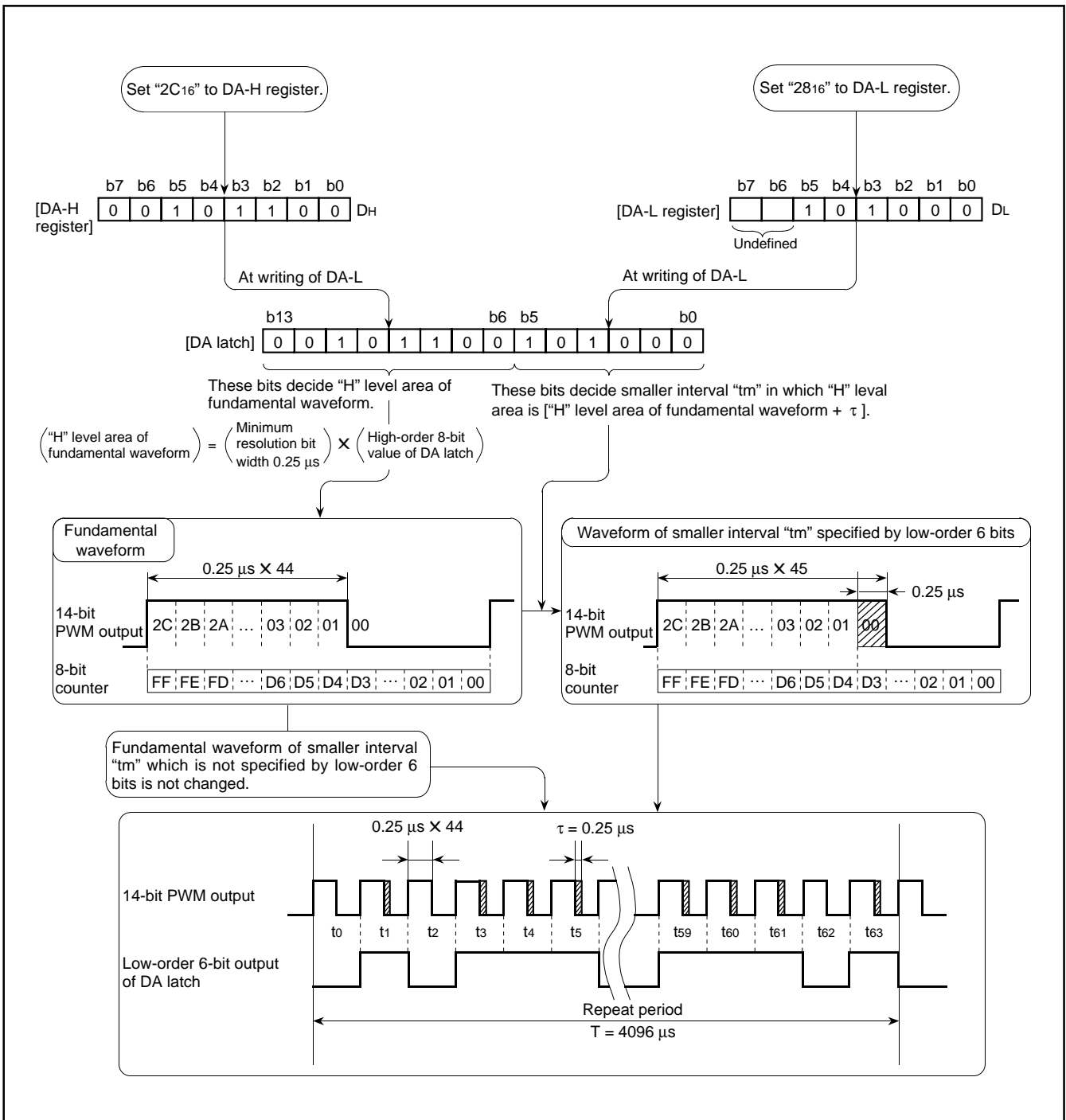

Fig. 8.7.3 14-bit PWM Output Example (f(XIN) = 8MHz)

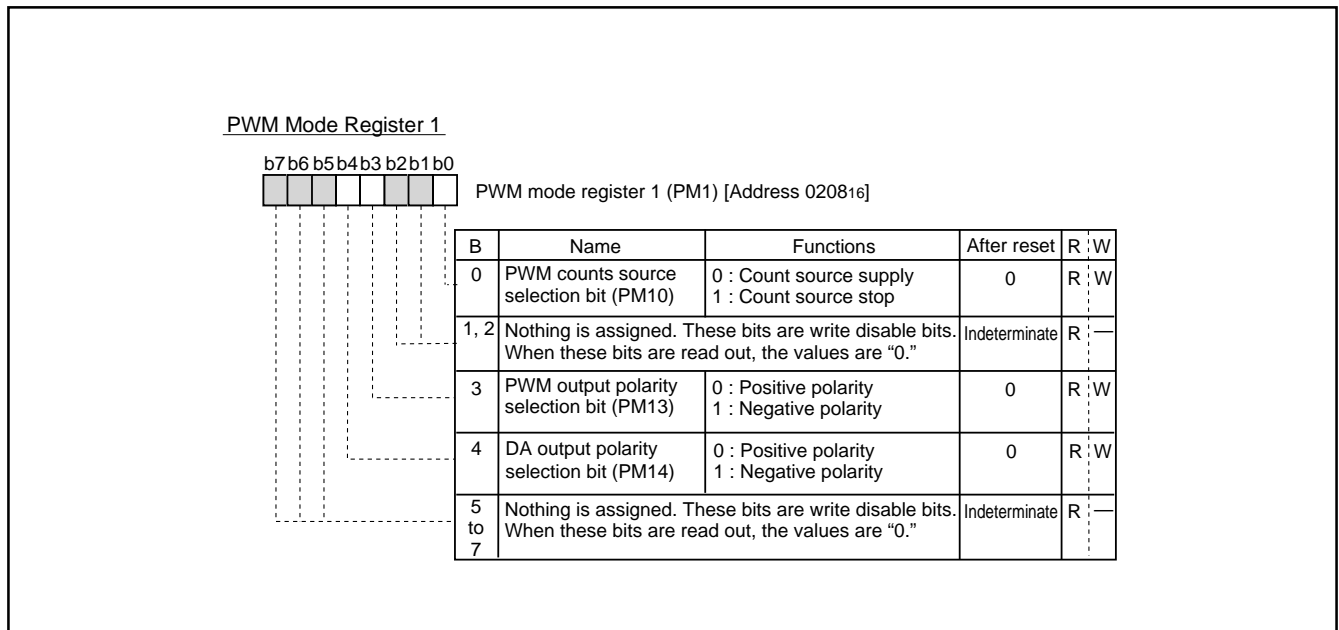

Fig. 8.7.3 PWM Mode Register 1

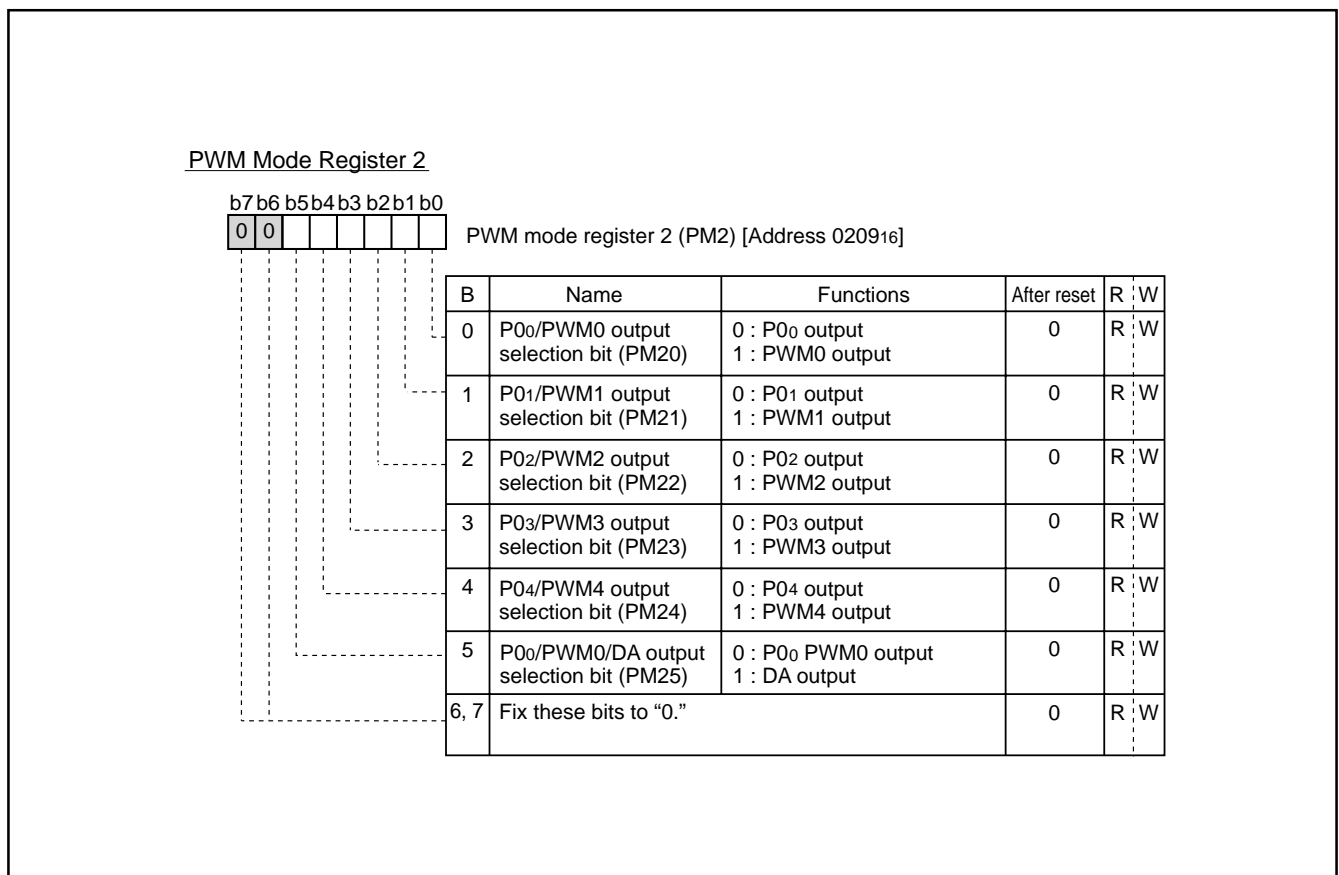

Fig. 8.7.4 PWM Mode Register 2

8.8 A-D COMPARATOR

The A-D comparator consists of a 7-bit D-A converter and a comparator. The A-D comparator block diagram is shown in Figure 8.8.1.

The reference voltage "V_{ref}" for D-A conversion is set by bits 0 to 6 of A-D control register 2 (address 00ED16).

The comparison result of the analog input voltage and the reference voltage "V_{ref}" is stored in bit 4 of A-D control register 1 (address 00EC16).

For A-D comparison, set "0" to corresponding bits of the direction register to use ports as analog input pins. Write the data to select analog input pins for bits 0 to 2 of A-D control register 1 and write the digital value corresponding to V_{ref} to be compared to bits 0 to 4 of A-D control register 2. The voltage comparison is started by writing to A-D control register 2, and it is completed after 16 machine cycles (NOP instruction X 8).

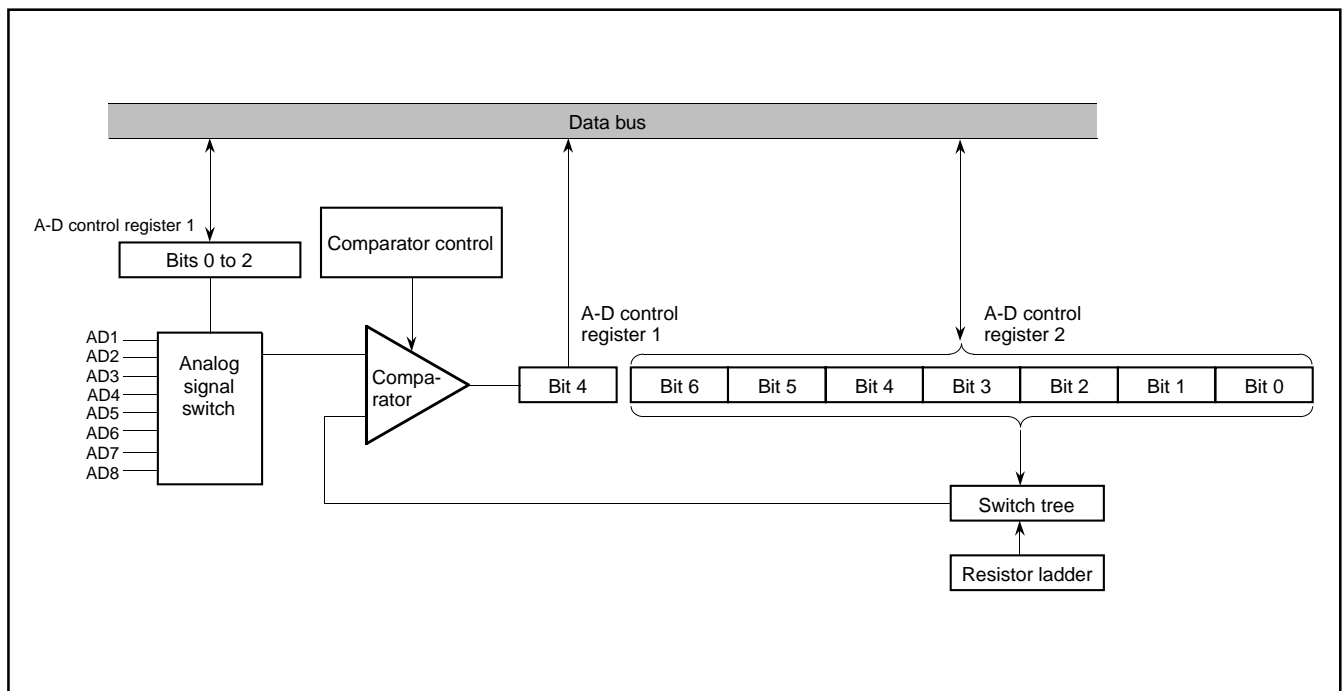

Fig. 8.8.1 A-D Comparator Block Diagram

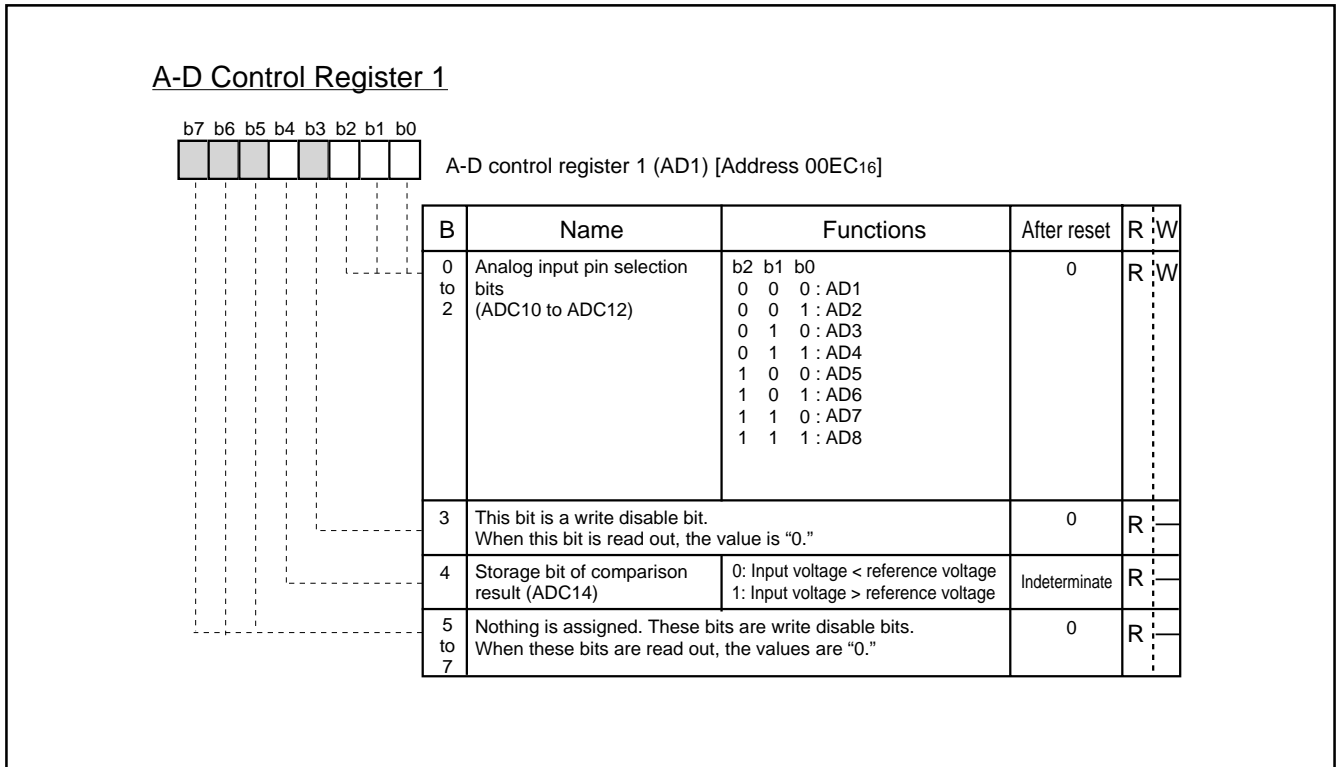

Fig. 8.8.2 A-D Control Register 1

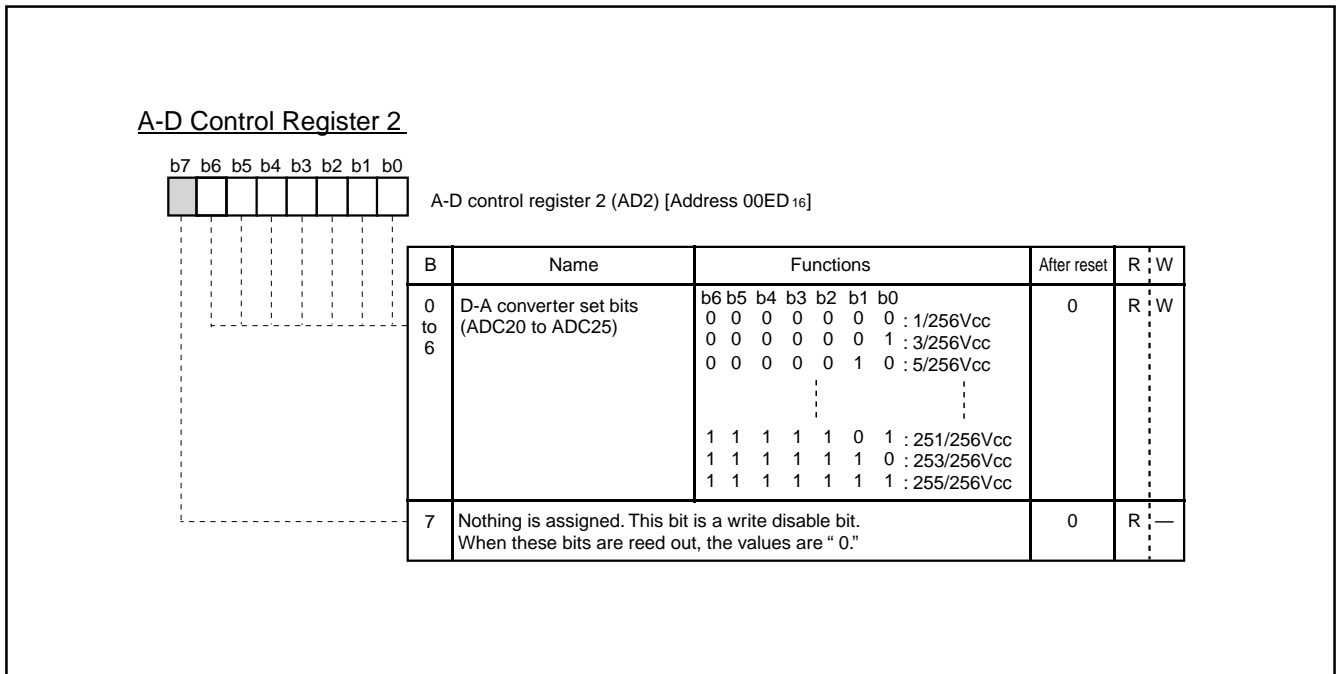

Fig. 8.8.3 A-D Control Register 2

8.9 ROM CORRECTION FUNCTION

This can correct program data in the ROM. Up to 2 addresses can be corrected; a program for correction is stored in the ROM correction vector in the RAM as the top address. There are 2 vectors for ROM correction :

Vector 1 : address 0300₁₆

Vector 2 : address 0320₁₆

Set the address of the ROM data to be corrected into the ROM correction address register. When the value of the counter matches the ROM data address in the top address of the ROM correction vector, the main program branches to the correction program stored in the ROM memory. To return from the correction program to the main program, the op code and operand of the JMP instruction (total of 3 bytes) are necessary at the end of the correction program.

The ROM correction function is controlled by the ROM correction enable register.

- Notes 1:** Specify the first address (op code address) of each instruction as the ROM correction address.
2: Use the JMP instruction (total of 3 bytes) to return from the correction program to the main program.
3: Do not set the same ROM correction address to both vectors 1 and 2.

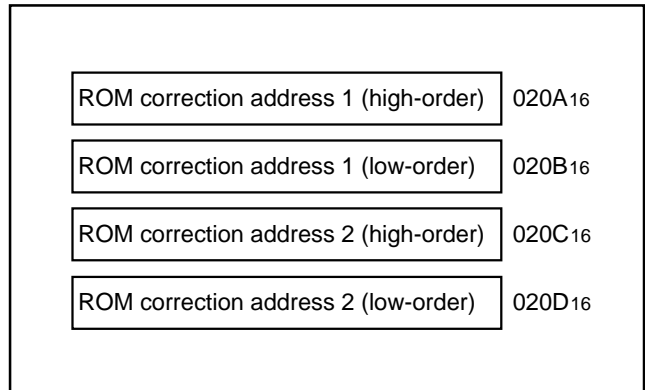

Fig. 8.9.1 ROM Correction Address Registers

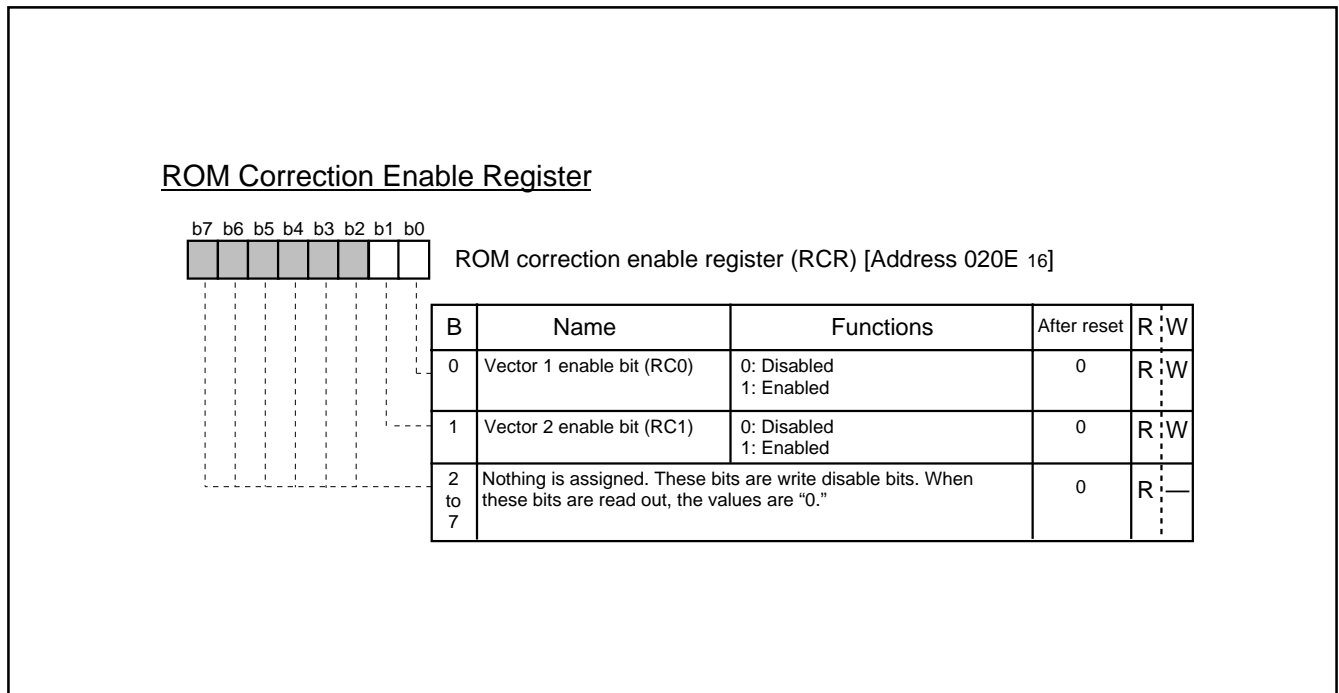

Fig. 8.9.2 ROM Correction Enable Register

8.10 OSD FUNCTIONS

Table 8.10.1 outlines the OSD functions.

This microcomputer incorporates an OSD circuit of 32 characters X 2 lines. There are also 3 display modes which are selected in block units. The display modes are selected by bits 0 and 1 of block control register i (i = 1 and 2).

The features of each mode are described below.

Table 8.10.1 Features of Each Display Mode

Parameter	Display mode		
	OSD1 mode (On-screen display 1 mode)	OSD2 mode (On-screen display 2 mode)	CD OSD mode (Color dot on screen display mode)
Number of display characters	32 characters X 2 lines		
Dot structure	16 X 26 dots (Character display area : 16 X 20 dots)	16 X 20 dots	16 X 20 dots
Kinds of characters	254 kinds		62 kinds
Kinds of character sizes	1 kinds	8 kinds	8 kinds
Pre-divide ratio (See note)	X 2 (fixed)	X 2, X 3	X 2, X 3
Dot size	1Tc X 1/2H	1TC X 1/2H, 1TC X 1H, 2TC X 2H, 3TC X 3H	1TC X 1/2H, 1TC X 1H, 2TC X 2H, 3TC X 3H
Attribute	Smooth italic, under line, flash	Border (black)	Dot coloring
Character font coloring	1 screen : 8 kinds (per character unit)		1 screen : 8 kinds (per dot unit)
Character background coloring	_____	1 screen : 8 kinds (per character unit)	1 screen : 8 kinds (per character unit)
OSD output	R, G, B		
Raster coloring	Possible (per character unit)		
Function	Auto solid space function Window function	_____	_____
Display position	Horizontal: 128 levels, Vertical: 512 levels		
Display expansion (multiline display)	Possible		

Note : The character size is specified with dot size and pre-divide ratio (refer to 8.10.2 Dot Size).

The OSD circuit has an extended display mode. This mode allows multiple lines (3 lines or more) to be displayed on the screen by interrupting the display each time one line is displayed and rewriting data in the block for which display has been terminated by software.

Figure 8.10.1 shows the configuration of an OSD character. Figure 8.10.2 shows the block diagram of the OSD circuit. Figure 8.10.3 shows the OSD control register. Figure 8.10.4 shows block control register i.

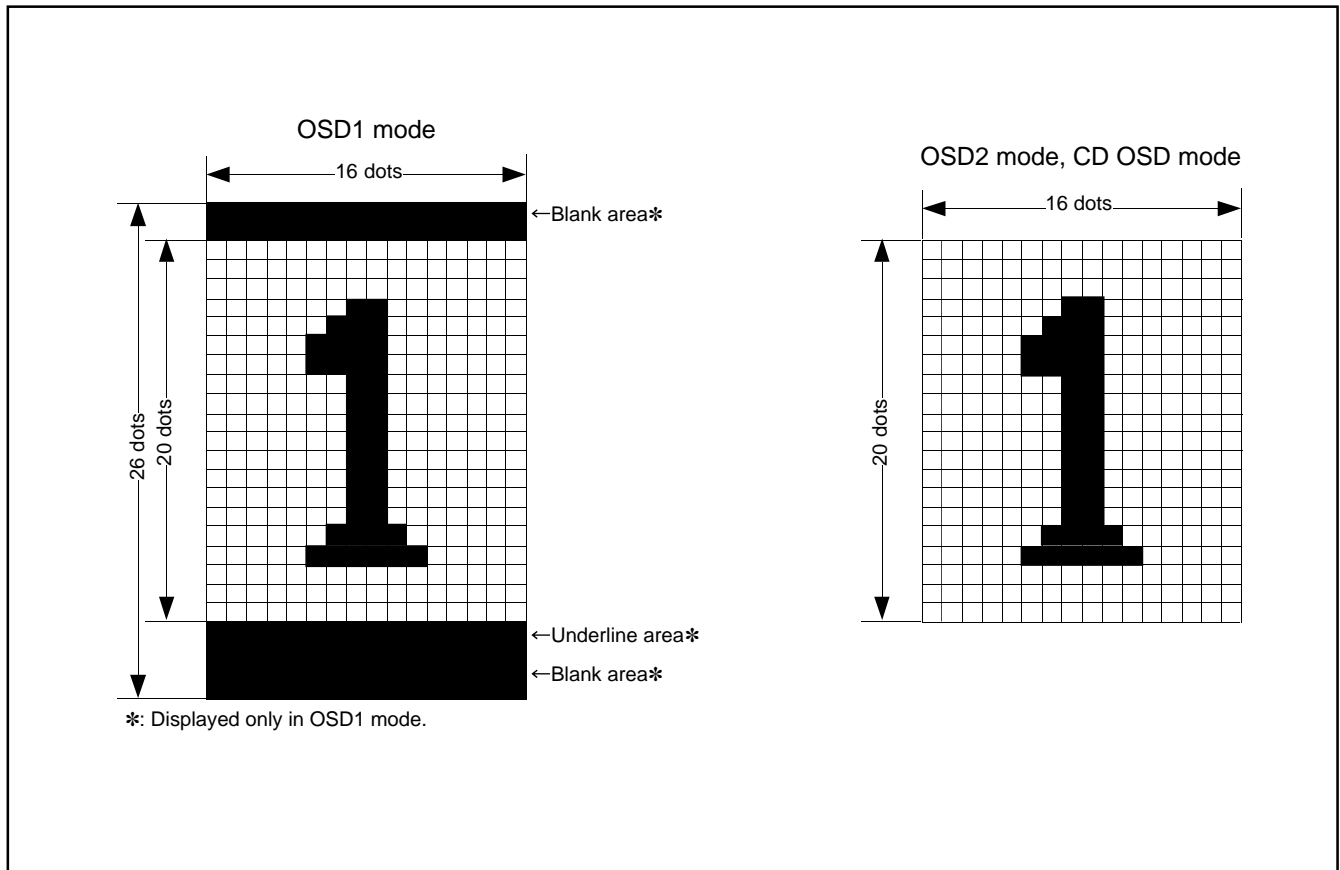

Fig. 8.10.1 Configuration of OSD Character Display Area

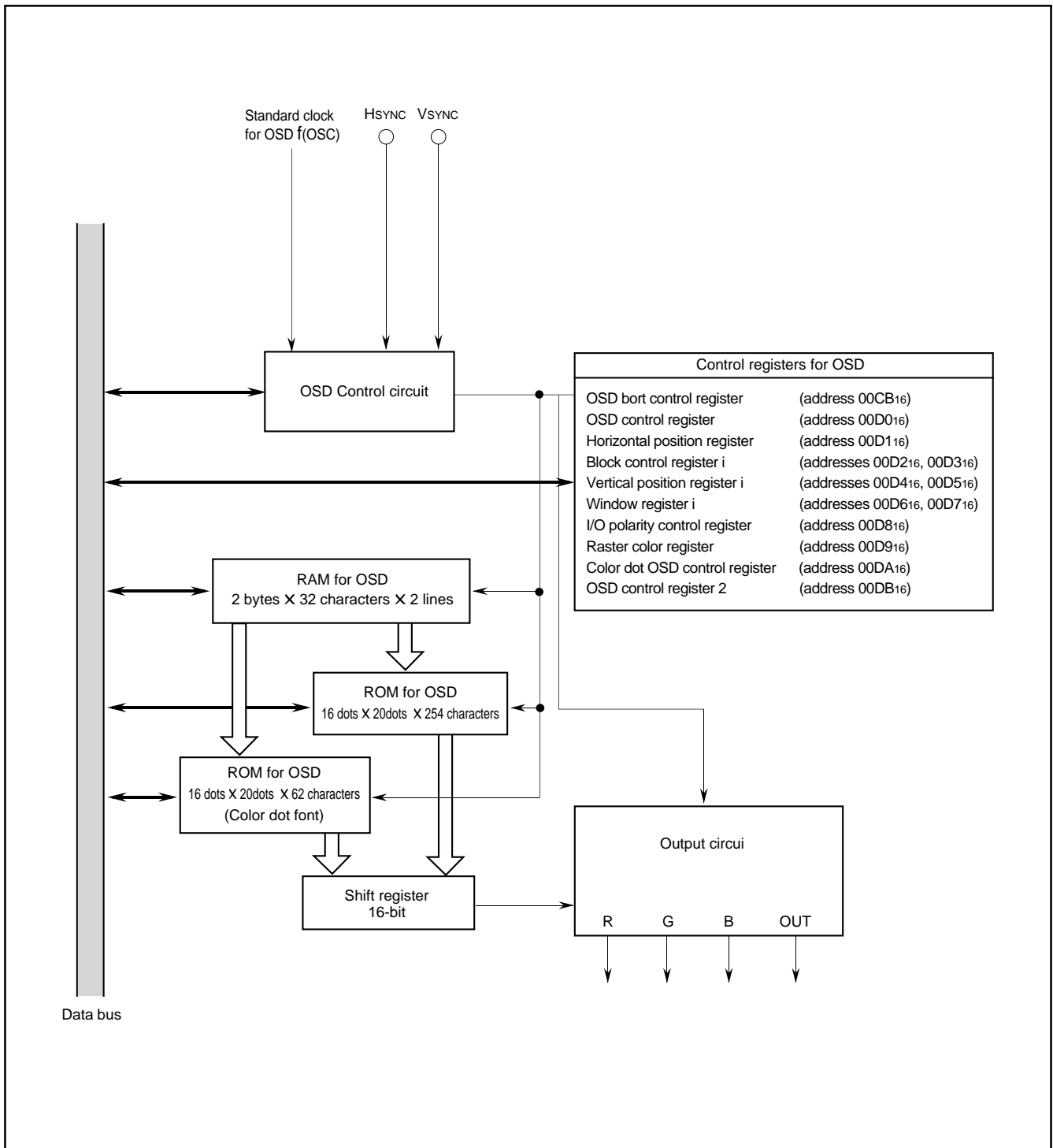
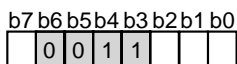

Fig. 8.10.2 Block Diagram of OSD Circuit

OSD Control Register



OSD control register (OC) [Address 00D016]

B	Name	Functions	After reset	R:W
0	OSD control bit (OC0) (See note 1)	0 : All-blocks display off 1 : All-blocks display on	0	R:W
1	Automatic solid space control bit (OC1)	0 : OFF 1 : ON	0	R:W
2	Window control bit (OC2)	0 : OFF 1 : ON	0	R:W
3,4	Fix these bits to "1."		0	R:W
5,6	Fix these bits to "0."		0	R:W
7	Pre-divide ratio selection bit (OC7) (See note 2)	0 : Divide ratio by the block control register 1 : Pre-divide ratios = X 1 for blocks 1 and 2	0	R:W

- Notes 1:** Even this bit is switched during display, the display screen remains unchanged until a rising (falling) of the next VSYNC
- 2:** This bit's priority is higher than BCi4 of Block Control Register i setting.
The pre-divide ratio 1 cannot be used in CD OSD mode.

Fig. 8.10.3 OSD Control Register

Block Control register i

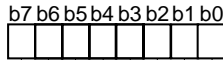

Block control register i (BCi) (i=1, 2) [Addresses 00D2₁₆ and 00D3₁₆]

B	Name	Functions	After reset	R	W
0, 1	Display mode selection bits (BCi0, BCi1) (See note 4)	b1 b0 0 0: Display OFF 0 1: OSD1 mode 1 0: OSD2 mode (Border OFF) 1 1: OSD2 mode (Border ON) /CD OSD mode (Border OFF)	Indeterminate	R	W
2, 3	Dot size selection bits (BCi2, BCi3) (See note 1)	b4 b3 b2 Pre-divide Ratio Dot Size 0 0 0 1Tc × 1/2H 0 0 1 1Tc × 1H 0 1 0 2Tc × 2H 0 1 1 3Tc × 3H × 2	Indeterminate	R	W
4	Pre-divide ratio selection bit (BCi4)	0 0 0 1Tc × 1/2H 0 0 1 1Tc × 1H 1 0 0 2Tc × 2H 1 0 1 3Tc × 3H × 3	Indeterminate	R	W
5	OUToutput control bit (BCi5)	0: 2 value output control 1: 3 value output control (See note 3)	Indeterminate	R	W
6	Vertical display start position control bit (BCi6)	BC16: Block 1 BC26: Block 1	Indeterminate	R	W
7	Window top/bottom boundary control bit (BCi7)	BC17: Window top boundary BC27: Window bottom boundary	Indeterminate	R	W

- Notes 1:** Tc is OSD clock cycle divided in pre-divide circuit.
2: H is HSYNC.
3: Refer to the corresponding figure 8.10.18.
4: Selection in OSD2 mode / CD OSD mode is performed in the bits 0 and 1 of color dot OSD control registration.

Fig. 8.10.4 Block Control Register i

Color dot OSD control register

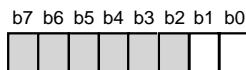

Color dot OSD control register (CDT) [Address 00DA₁₆]

B	Name	Functions	After reset	R	W
0	Color dot Block 1 Setting bit (CDT0)	0 : OSD2 mode 1 : CD OSD mode	Indeterminate	R	W
1	Color dot Block 2 Setting bit (CDT1)	0 : OSD2 mode 1 : CD OSD mode	Indeterminate	R	W
2 to 7	Nothing is assigned. This bit is write disable bit. When this bit is read out, the value is "Indeterminate."		Indeterminate	R	—

Fig. 8.10.5 Color dot OSD Control Register

8.10.1 Display Position

The display positions of characters are specified in units called "blocks." There are 2 blocks : blocks 1 and 2. Up to 32 characters can be displayed in each block (refer to "8.10.5 Memory for OSD"). The display position of each block can be set in both horizontal and vertical directions by software.

The display start position in the horizontal direction can be selected for all blocks from 128-step display positions in units of 4TOSC (TOSC = OSD oscillation cycle).

The display start position in the vertical direction for each block can be selected from 512-step display positions in units of 1 TH (in bi-scan mode : 2 TH) (TH = HSYNC cycle).

Blocks are displayed in conformance with the following rules:

- When the display position of block 1 is overlapped with that of block 2 (Figure 8.10.6 (b)), the block 1 is displayed on the front.
- When another block display position appears while one block is displayed (Figure 8.10.6 (c)), the block with a larger set value as the vertical display start position is displayed.

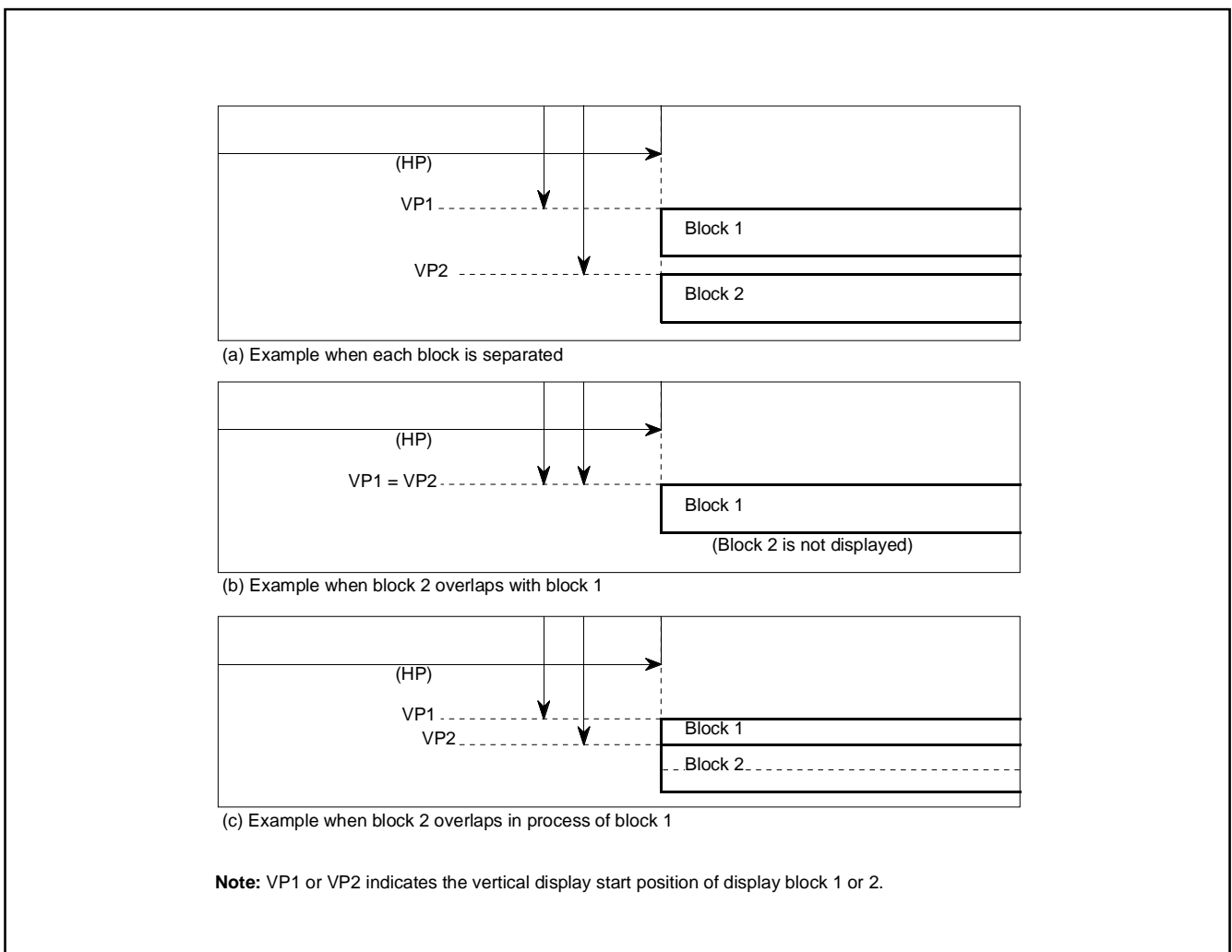

Fig. 8.10.6 Display Position

The vertical display start position is determined by counting the horizontal sync signal (HSYNC). At this time, when VSYNC and HSYNC are positive polarity (negative polarity), the count starts at the rising edge (falling edge) of HSYNC signal after the fixed cycle of the rising edge (falling edge) of VSYNC signal. So the interval from the rising edge (falling edge) of VSYNC signal to the rising edge (falling edge) of HSYNC signal needs enough time (2 machine cycles or more) to avoid jitter. The polarity of HSYNC and VSYNC signals can select with the I/O polarity control register (address 00D816).

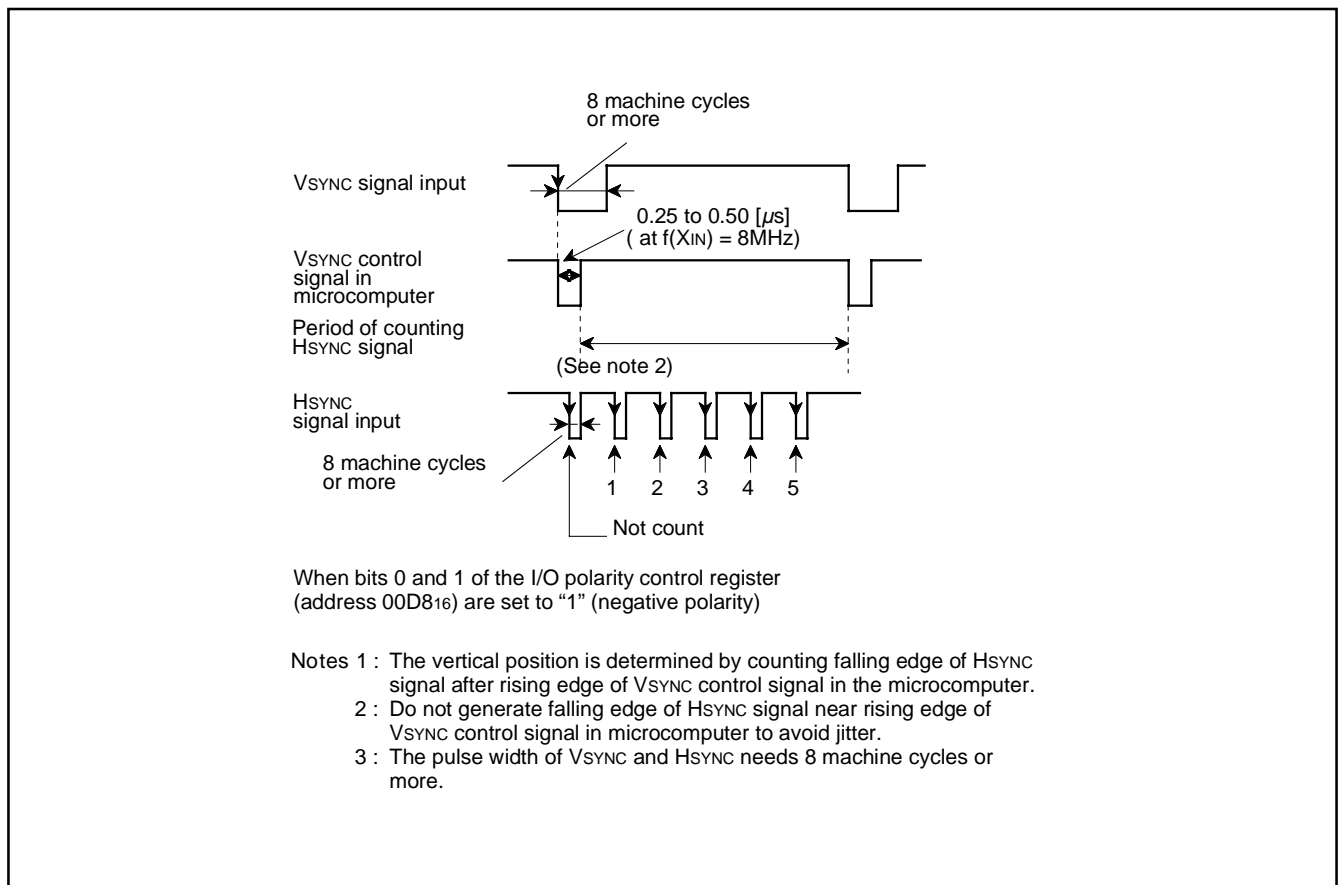

Fig. 8.10.7 Supplement Explanation for Display Position

The vertical display start position for each block can be set in 512 steps (where each step is 1TH (TH: HSYNC cycle)) as values "0016" to "FF16" in vertical position register i (i = 1 and 2) (addresses 00D416 and 00D516) and values "0" or "1" in bit 6 of block control register i (i = 1 and 2) (addresses 00D216 and 00D316). The vertical position register is shown in Figure 8.10.8.

The vertical display start position of both blocks can be switched in each step to 1TH or 2TH by setting values "0" or "1" in bit 1 of OSD control register 2 (address 00DB16).

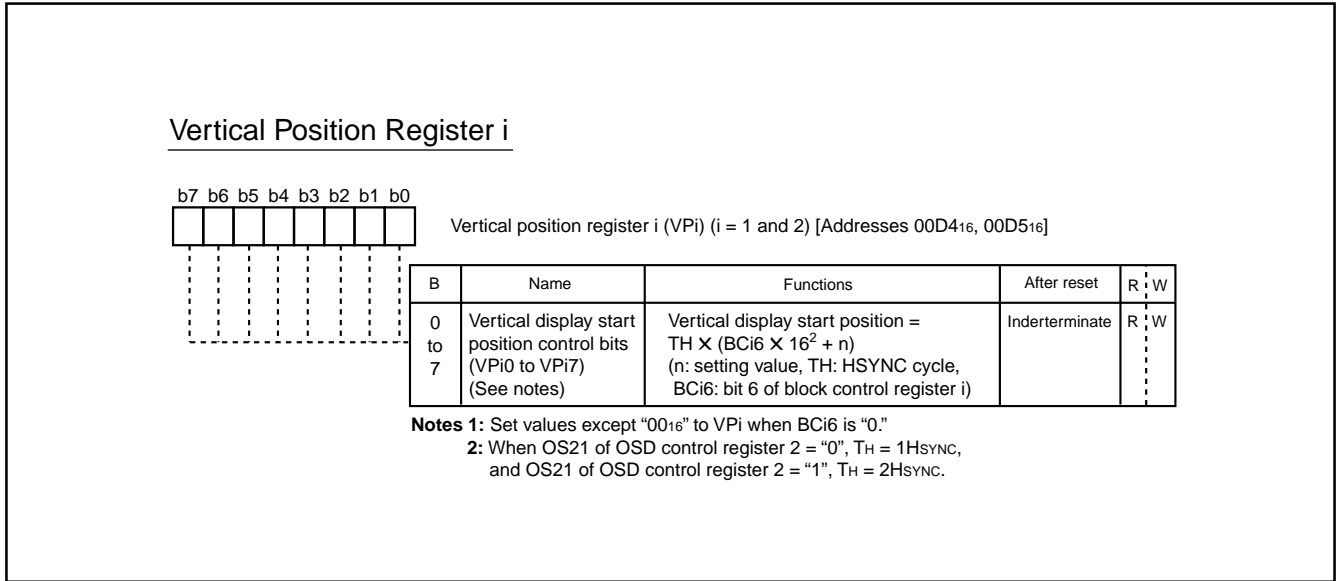

Fig. 8.10.8 Vertical Position Register i (i = 1 and 2)

The horizontal display start position is common to all blocks, and can be set in 128 steps (where 1 step is 4Tosc, TOSC being the OSD oscillation cycle) as values "0016" to "FF16" in bits 0 to 6 of the horizontal position register (address 00D116). The horizontal position register is shown in Figure 8.10.9.

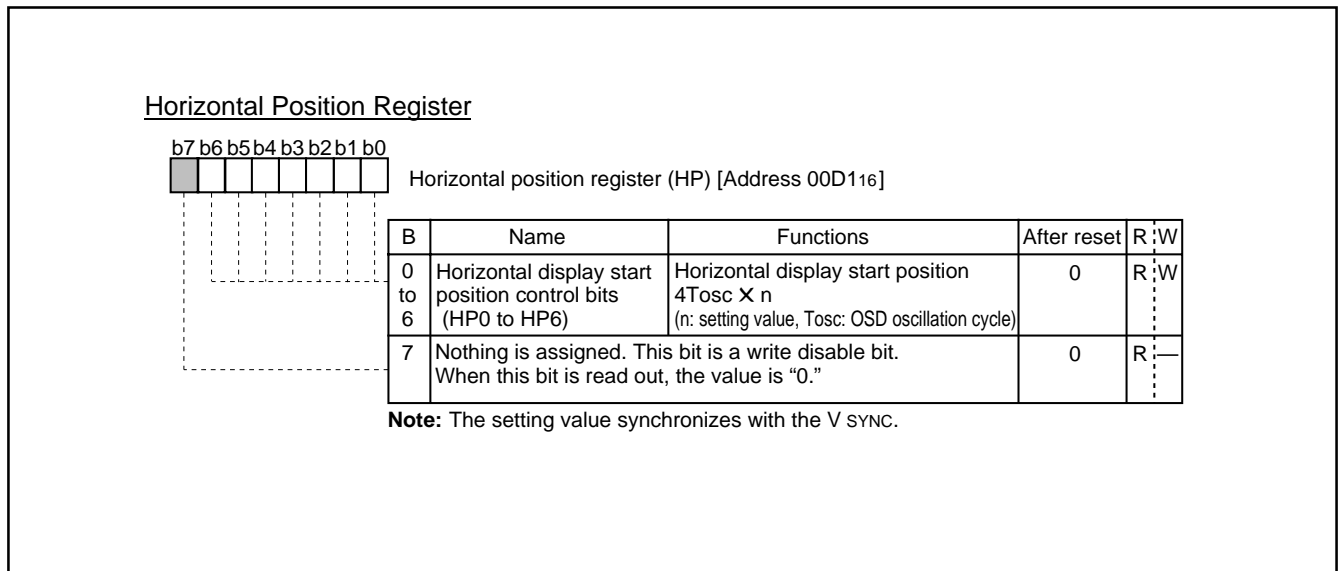

Fig. 8.10.9 Horizontal Position Register

- Notes 1 :** 1Tc (Tc : OSD clock cycle divided in pre-divide circuit) gap occurs between the horizontal display start position set by the horizontal position register and the most left dot of the 1st block. Accordingly, when 2 blocks have different pre-divide ratios, their horizontal display start position will not match.
- 2 :** When setting "0016" to the horizontal position register, it needs an approximately 62Tosc (= Tdef) interval from a rising edge (when negative polarity is selected) of HSYNC signal to the horizontal display start position.

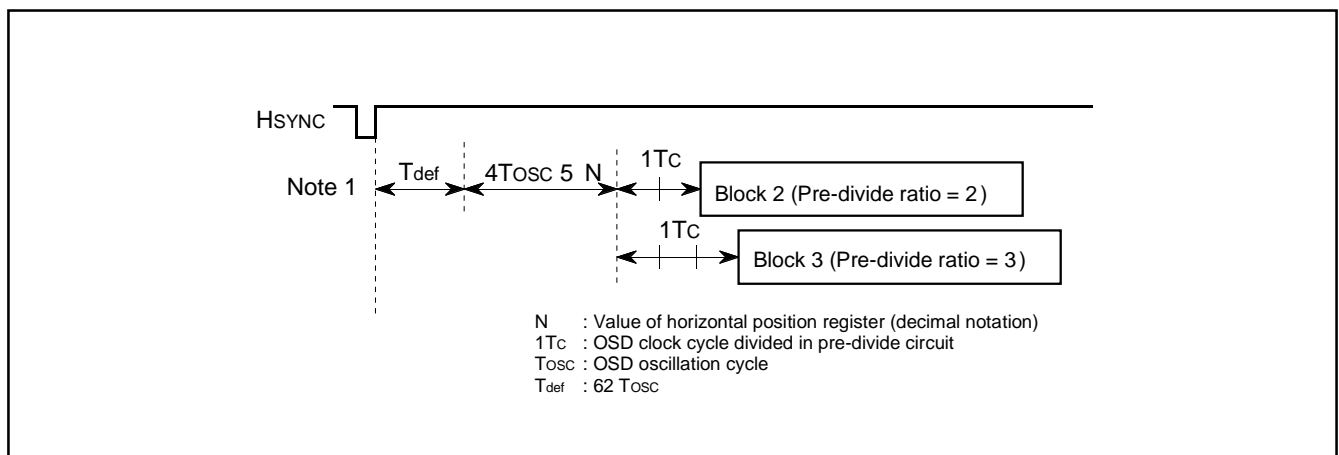

Fig. 8.10.10 Notes on Horizontal Display Start Position

8.10.2 Dot Size

The dot size can be selected in block units. The vertical dot size is determined by dividing HSYNC in the vertical dot size control circuit. The horizontal dot size in is determined by dividing the following clock in the horizontal dot size control circuit : the clock gained by dividing the f(OSC) in the pre-divide circuit. The clock cycle divided in the pre-divide circuit is defined as 1Tc.

The dot size of each block is specified by bits 2 to 4 of block control register i.

Refer to Figure 8.10.4 for the structure of the block control register. The block diagram of the dot size control circuit is shown in Figure 8.10.11.

The pre-divide ratio is specified by bit 7 of the OSD control register (address 00D016) and bit 4 of block control register i (addresses 00D216 and 00D316) .

When bit 7 of the OSD control register (address 00D016) is set to "0," the double or triple pre-divide ratio can be chosen per block unit by bit 4 of block control register i. And then, when it is set to "1", the pre-divide ratio increases 1 time (both blocks 1 and 2). The pre-divided dot size can be specified per block unit by bits 2 and 3 of block control register i.

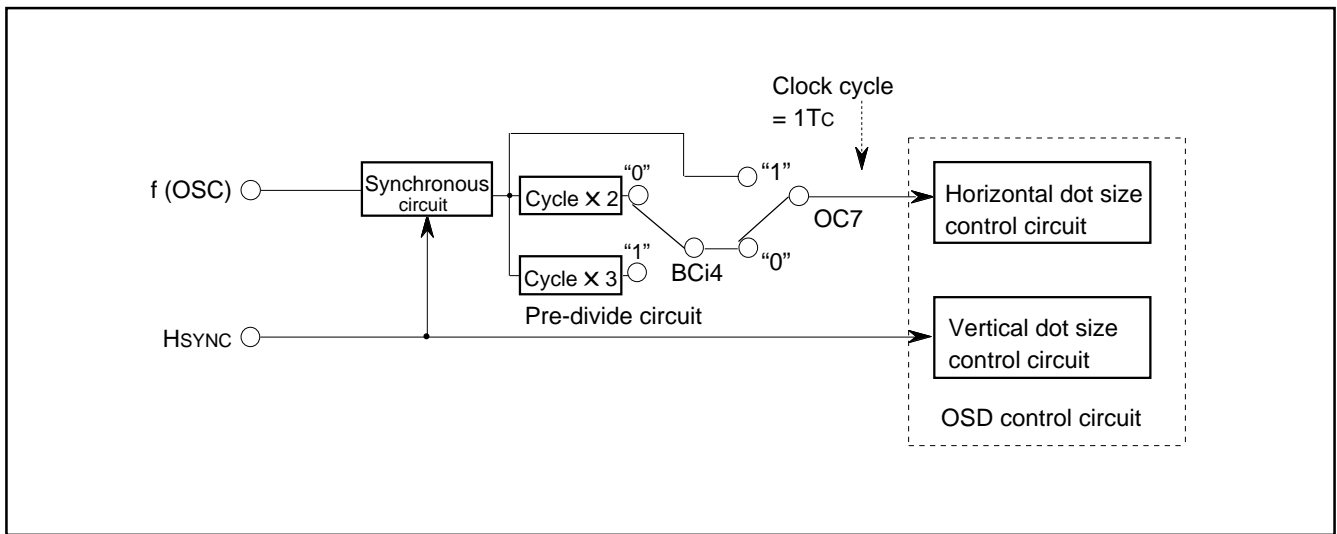

Fig. 8.10.11. Block Diagram of Dot Size Control Circuit

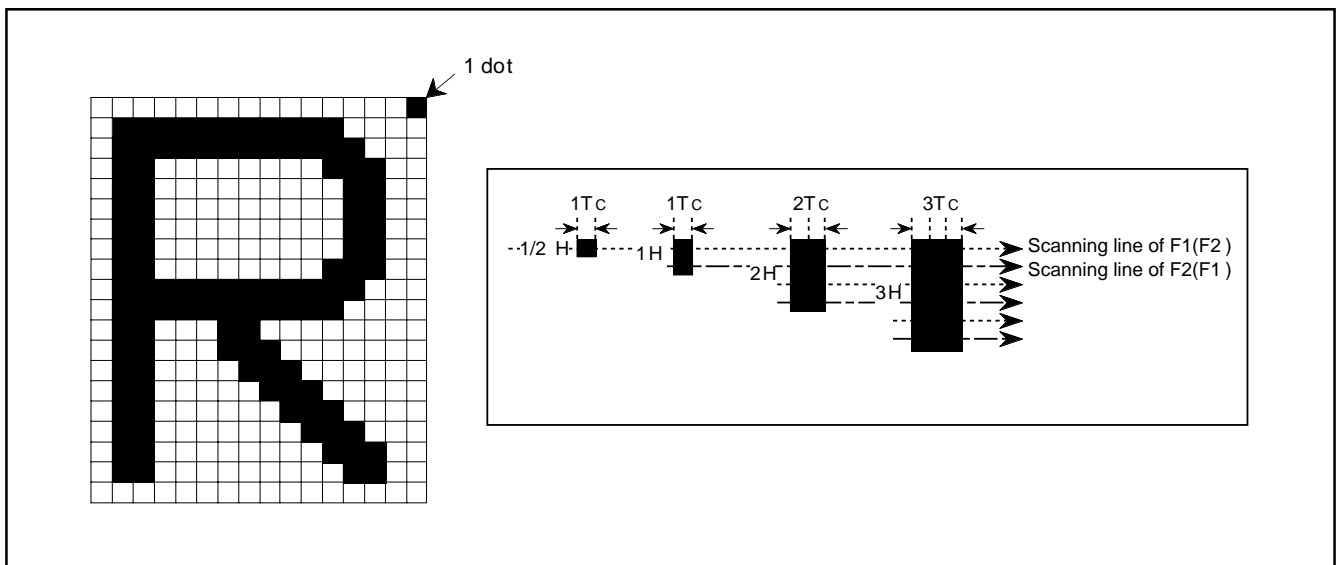

Fig. 8.10.12 Definition of Dot Sizes

8.10.3 Clock for OSD

OSD clock f (osc) generated based on the reference clock from the pin XIN.(refer to 8.14)

8.10.4 Field Determination Display

When displaying a block with vertical dot size of 1/2H, the differences in the synchronizing signal waveform of the interlacing system determine whether the field is odd or even. The dot lines 0 or 1, corresponding to each field, are displayed alternately (refer to Figure 8.10.14.)

In the following, the field determination standard for the case where both the horizontal sync signal and the vertical sync signal are negative-polarity inputs will be explained. A field determination is determined by detecting the time from a falling edge of the horizontal sync signal until a falling edge of the VSYNC control signal (refer to Figure 8.10.7) in the microcomputer and then comparing this time with the time of the previous field. When the time is longer than the previous time, it is regarded as even field. When the time is shorter, it is regarded as odd field

The contents of this field can be read out by the field determination flag (bit 6 of the I/O polarity control register at address 00D816). A dot line is specified by bit 5 of the I/O polarity control register (refer to Figure 8.10.14).

However, the field determination flag read out from the CPU is fixed to "0" for even fields or "1" for odd fields, regardless of bit 5.

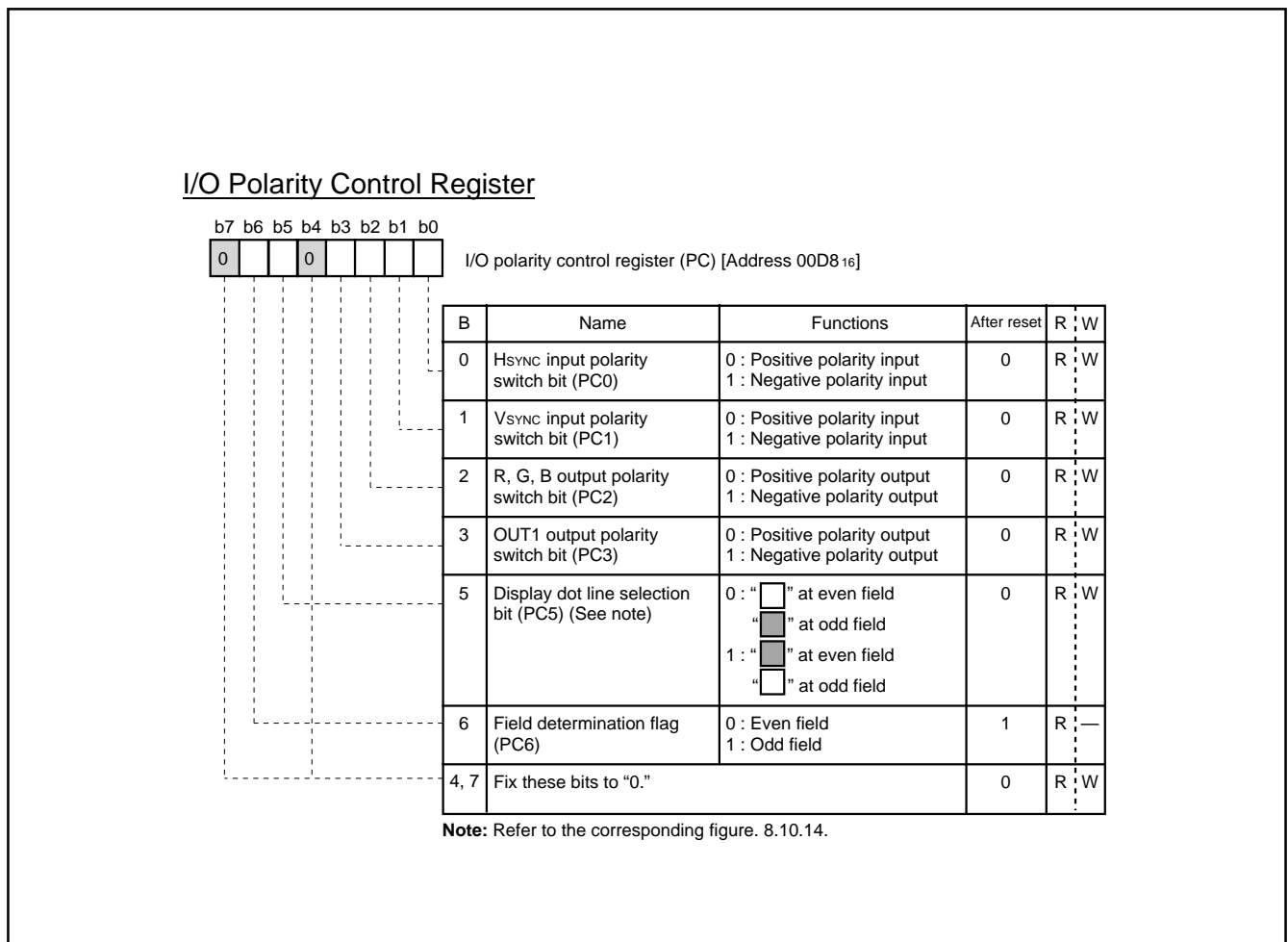
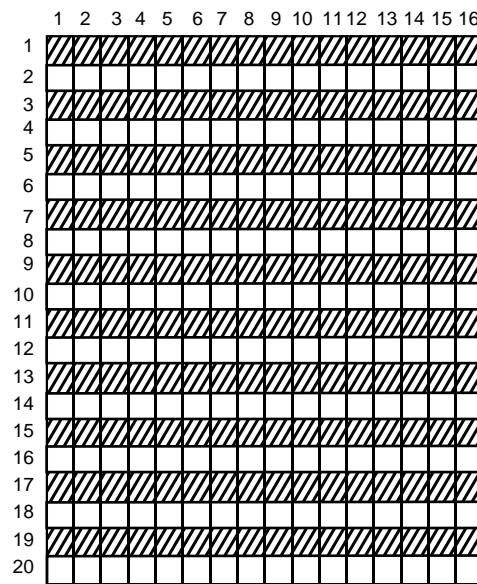
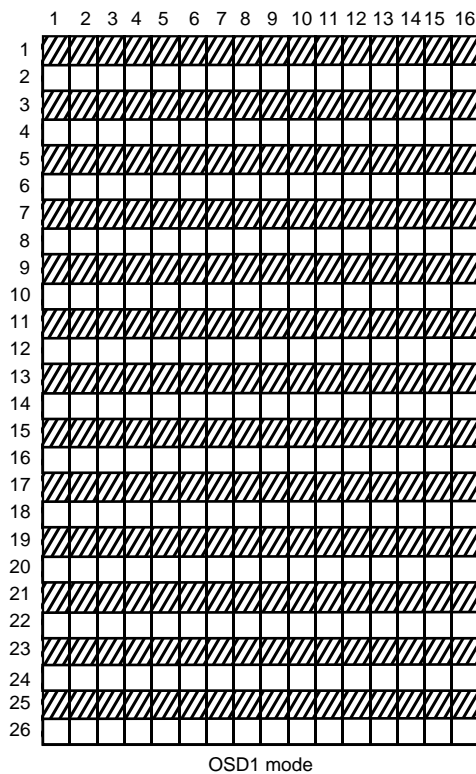

Fig. 8.10.13 I/O Polarity Control Register

Both Hsync signal and Vsync signal are negative-polarity input

Hsync		Field	Field determination flag(Note)	Display dot line selection bit	Display dot line
	(n - 1) field (Odd-numbered)	Odd			
	Upper : Vsync signal	Even	0 (T2 > T1)	0	Dot line 1 <input type="checkbox"/>
	Lower : Vsync control signal in micro-computer	Odd	1 (T3 < T2)	0	Dot line 0 <input checked="" type="checkbox"/>
				1	Dot line 1 <input type="checkbox"/>

When using the field determination flag, be sure to set bit 0 of the PWM mode register 1 (address 0208 16) to "0."



When the display dot line selection bit is "0," the "□" font is displayed at even field, the "▨" font is displayed at odd field. Bit 6 of the I/O polarity control register can be read as the field determination flag : "1" is read at odd field, "0" is read at even field.

OSD ROM font configuration diagram

Note : The field determination flag changes at a rising edge of the V sync control signal (negative-polarity input) in the microcomputer.

Fig. 8.10.14 Relation between Field Determination Flag and Display Font

8.10.5 Memory for OSD

There are 2 types of memory for OSD: OSD ROM used to store character dot data and OSD RAM used to specify the characters and colors to be displayed.

OSD ROM : addresses 11400₁₆ to 13BFF₁₆,
 addresses 1D400₁₆ to 1FBFF₁₆
 OSD RAM : addresses 0800₁₆ to 087F₁₆

(1) OSD ROM

Character font data is stored in the character font area of OSD ROM, and color dot font data is stored in color dot font area. To specify the kinds of character font, it is necessary to write the character code into the OSD RAM.

The storing address of character font data is shown in Fig. 8.10.15, and the storing address of color dot font data is shown in Fig. 8.10.16. A character font is 254 kinds, color dot font is 62 kinds is storable.

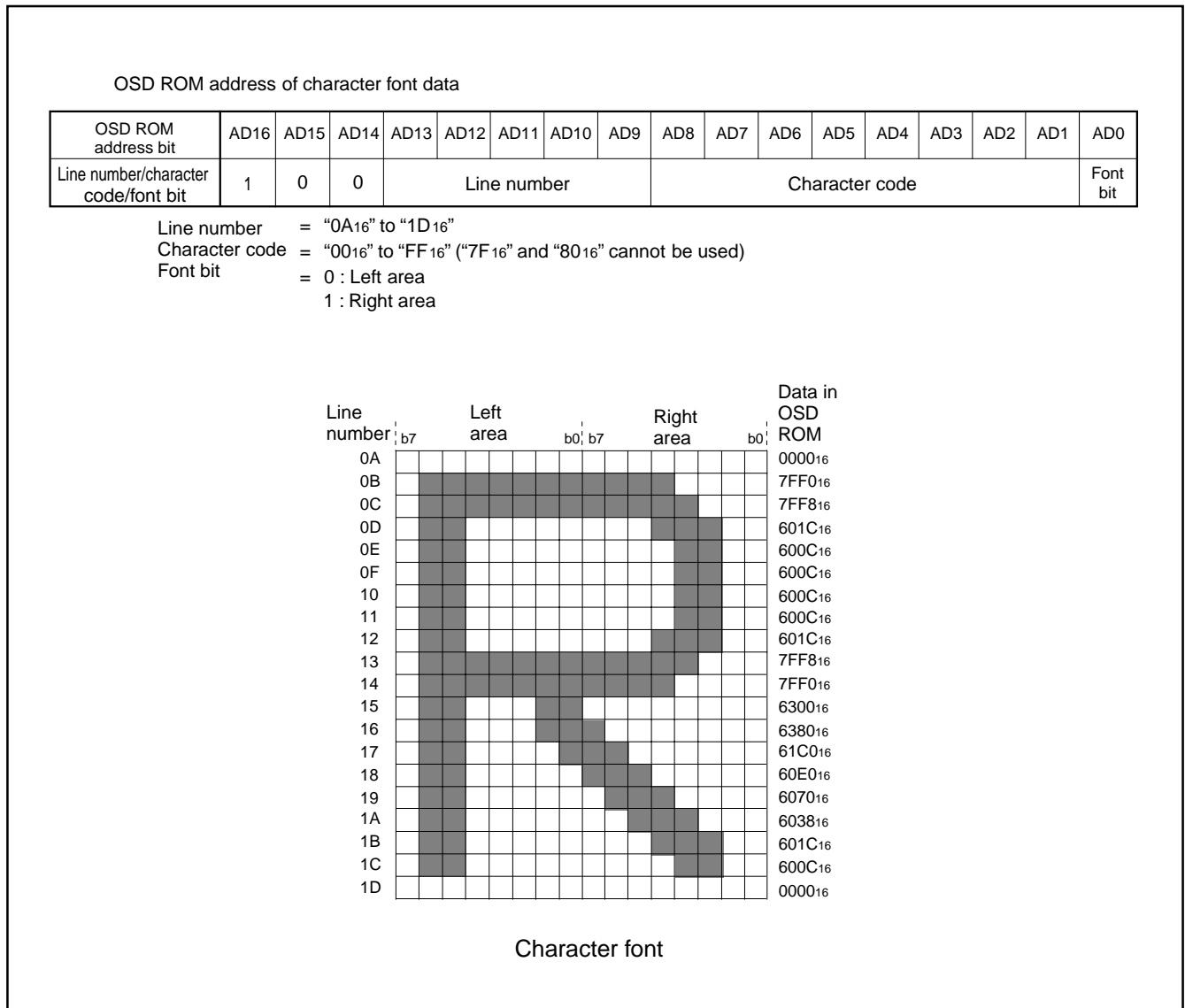

Fig. 8.10.15 Character Font Data Storing Address

OSD ROM address of color font data

OSD ROM address bit	AD16	AD15	AD14	AD13	AD12	AD11	AD10	AD9	AD8	AD7	AD6	AD5	AD4	AD3	AD2	AD1	AD0
line number/color,font/character code/font bit	1	1	1	Line number					color / font code		Character code						Font bit

Line number = "0A₁₆" to "1D₁₆"

Color/font code = 00 : Red 01 : Green 10 : Blue 11 : font

Character code = "00₁₆" to "3F₁₆" ("15₁₆" and "2A₁₆" cannot be used)

Font bit = 0 : Left area 1 : Right area

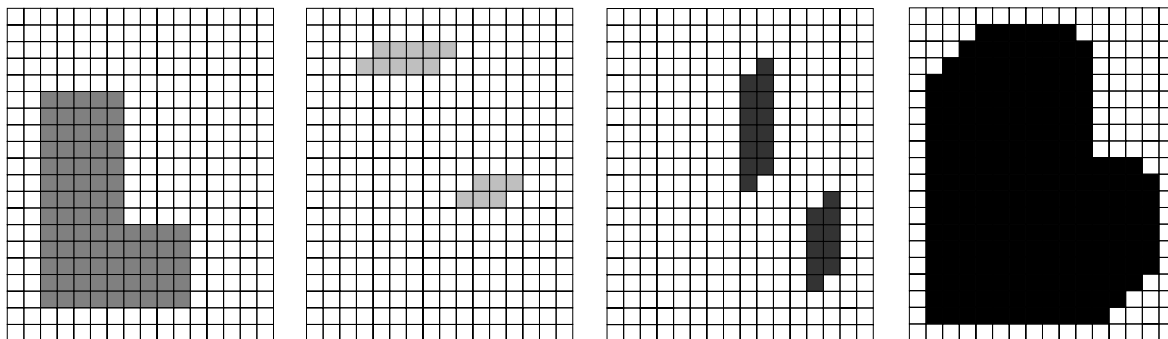

R data

G data

B data

Font data

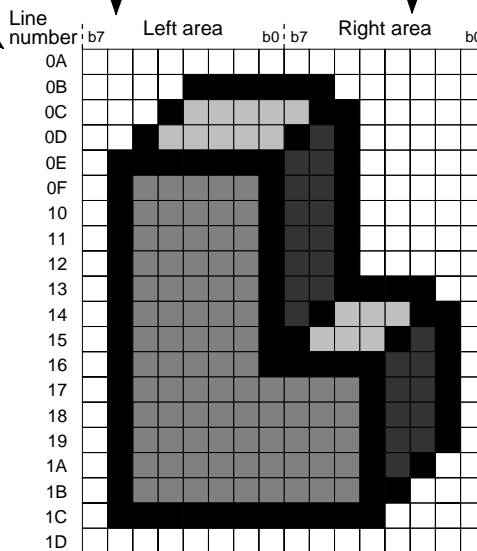

Color dot font

Fig. 8.10.16 Color dot Font Data Storing Address

Notes 1 : The 80-byte addresses corresponding to the character code "7F₁₆" and "80₁₆" of a character font, 320-byte addresses corresponding to the character code "15₁₆" and "2A₁₆" of a color dot font, in the OSD ROM are the test data storing area. Set data to the area as follows.

<Test data storing area>
 addresses 11000₁₆ + (4 + 2n) X 100₁₆ + FE₁₆ to
 11000₁₆ + (5 + 2n) X 100₁₆ + 01₁₆
 (n = 0 to 19)

addresses 1D400₁₆ + (8 X n) X 10₁₆ + 2A₁₆ to
 1D400₁₆ + (8 X n) X 100₁₆ + 2B₁₆
 (n = 0 to 79)

addresses 1D400₁₆ + (8 X n) X 10₁₆ + 54₁₆ to
 1D400₁₆ + (8 X n) X 10₁₆ + 55₁₆
 (n = 0 to 79)

(1)Mask version

Set "FF₁₆" to the area (This sample has test data in this area but the actual product will have different data.) When using our font editor, the test data is written automatically.

(2)EPROM version

Set the test data to the area. When using our font editor, the test data is written automatically.

■M37161EFP

Character font

<"7F ₁₆ "> address (test data)		<"80 ₁₆ "> address (test data)	
114FE ₁₆ (09 ₁₆),	114FF ₁₆ (51 ₁₆),	11500 ₁₆ (90 ₁₆),	11501 ₁₆ (A1 ₁₆)
116FE ₁₆ (00 ₁₆),	116FF ₁₆ (52 ₁₆),	11700 ₁₆ (00 ₁₆),	11701 ₁₆ (A2 ₁₆)
118FE ₁₆ (12 ₁₆),	118FF ₁₆ (53 ₁₆),	11900 ₁₆ (48 ₁₆),	11901 ₁₆ (A3 ₁₆)
11AFE ₁₆ (00 ₁₆),	11AFF ₁₆ (54 ₁₆),	11B00 ₁₆ (00 ₁₆),	11B01 ₁₆ (A4 ₁₆)
11CFE ₁₆ (24 ₁₆),	11CFF ₁₆ (55 ₁₆),	11D00 ₁₆ (24 ₁₆),	11D01 ₁₆ (A5 ₁₆)
11EFE ₁₆ (00 ₁₆),	11EFF ₁₆ (56 ₁₆),	11F00 ₁₆ (00 ₁₆),	11F01 ₁₆ (A6 ₁₆)
120FE ₁₆ (88 ₁₆),	120FF ₁₆ (57 ₁₆),	12100 ₁₆ (12 ₁₆),	12101 ₁₆ (A7 ₁₆)
122FE ₁₆ (00 ₁₆),	122FF ₁₆ (58 ₁₆),	12300 ₁₆ (00 ₁₆),	12301 ₁₆ (A8 ₁₆)
124FE ₁₆ (90 ₁₆),	124FF ₁₆ (59 ₁₆),	12500 ₁₆ (09 ₁₆),	12501 ₁₆ (A9 ₁₆)
126FE ₁₆ (48 ₁₆),	126FF ₁₆ (5A ₁₆),	12700 ₁₆ (00 ₁₆),	12701 ₁₆ (AA ₁₆)
128FE ₁₆ (24 ₁₆),	128FF ₁₆ (5B ₁₆),	12900 ₁₆ (81 ₁₆),	12901 ₁₆ (AB ₁₆)
12AFE ₁₆ (00 ₁₆),	12AFF ₁₆ (5C ₁₆),	12B00 ₁₆ (18 ₁₆),	12B01 ₁₆ (AC ₁₆)
12CFE ₁₆ (24 ₁₆),	12CFF ₁₆ (5D ₁₆),	12D00 ₁₆ (00 ₁₆),	12D01 ₁₆ (AD ₁₆)
12EFE ₁₆ (48 ₁₆),	12EFF ₁₆ (5E ₁₆),	12F00 ₁₆ (42 ₁₆),	12F01 ₁₆ (AE ₁₆)
130FE ₁₆ (00 ₁₆),	130FF ₁₆ (5F ₁₆),	13100 ₁₆ (24 ₁₆),	13101 ₁₆ (AF ₁₆)
132FE ₁₆ (48 ₁₆),	132FF ₁₆ (50 ₁₆),	13300 ₁₆ (00 ₁₆),	13301 ₁₆ (B0 ₁₆)
134FE ₁₆ (90 ₁₆),	134FF ₁₆ (51 ₁₆),	13500 ₁₆ (81 ₁₆),	13501 ₁₆ (B1 ₁₆)
136FE ₁₆ (00 ₁₆),	136FF ₁₆ (52 ₁₆),	13700 ₁₆ (0C ₁₆),	13701 ₁₆ (B2 ₁₆)
138FE ₁₆ (01 ₁₆),	138FF ₁₆ (53 ₁₆),	13900 ₁₆ (06 ₁₆),	13901 ₁₆ (B3 ₁₆)
13AFE ₁₆ (80 ₁₆),	13AFF ₁₆ (53 ₁₆),	13B00 ₁₆ (00 ₁₆),	13B01 ₁₆ (B4 ₁₆)

Color dot font

<"1516"> address (test data)

1D42A ₁₆ (B8 ₁₆),	1D42B ₁₆ (36 ₁₆),	1D4AA ₁₆ (C8 ₁₆),	1D4AB ₁₆ (C7 ₁₆),	1D52A ₁₆ (93 ₁₆),	1D52B ₁₆ (A3 ₁₆),	1D5AA ₁₆ (C9 ₁₆),	1D5AB ₁₆ (B8 ₁₆),
1D62A ₁₆ (B8 ₁₆),	1D62B ₁₆ (C3 ₁₆),	1D6AA ₁₆ (09 ₁₆),	1D6AB ₁₆ (5F ₁₆),	1D72A ₁₆ (8C ₁₆),	1D72B ₁₆ (BA ₁₆),	1D7AA ₁₆ (26 ₁₆),	1D7AB ₁₆ (D6 ₁₆),
1D82A ₁₆ (55 ₁₆),	1D82B ₁₆ (55 ₁₆),	1D8AA ₁₆ (33 ₁₆),	1D8AB ₁₆ (33 ₁₆),	1D92A ₁₆ (0F ₁₆),	1D92B ₁₆ (0F ₁₆),	1D9AA ₁₆ (01 ₁₆),	1D9AB ₁₆ (FE ₁₆),
1DA2A ₁₆ (AA ₁₆),	1DA2B ₁₆ (AA ₁₆),	1DAAA ₁₆ (CC ₁₆),	1DAAB ₁₆ (CC ₁₆),	1DB2A ₁₆ (F0 ₁₆),	1DB2B ₁₆ (F0 ₁₆),	1DBAA ₁₆ (7F ₁₆),	1DBAB ₁₆ (80 ₁₆),
1DC2A ₁₆ (0B ₁₆),	1DC2B ₁₆ (CB ₁₆),	1DCAA ₁₆ (B5 ₁₆),	1DCAB ₁₆ (C1 ₁₆),	1DD2A ₁₆ (72 ₁₆),	1DD2B ₁₆ (53 ₁₆),	1DDAA ₁₆ (AB ₁₆),	1DDAB ₁₆ (15 ₁₆),
1DE2A ₁₆ (17 ₁₆),	1DE2B ₁₆ (1E ₁₆),	1DEAA ₁₆ (30 ₁₆),	1DEAB ₁₆ (7D ₁₆),	1DF2A ₁₆ (A2 ₁₆),	1DF2B ₁₆ (97 ₁₆),	1DFAA ₁₆ (54 ₁₆),	1DFAB ₁₆ (C7 ₁₆),
1E02A ₁₆ (AE ₁₆),	1E02B ₁₆ (1A ₁₆),	1E0AA ₁₆ (7E ₁₆),	1E0AB ₁₆ (24 ₁₆),	1E12A ₁₆ (25 ₁₆),	1E12B ₁₆ (7C ₁₆),	1E1AA ₁₆ (16 ₁₆),	1E1AB ₁₆ (6B ₁₆),
1E22A ₁₆ (57 ₁₆),	1E22B ₁₆ (2C ₁₆),	1E2AA ₁₆ (E4 ₁₆),	1E2AB ₁₆ (E8 ₁₆),	1E32A ₁₆ (50 ₁₆),	1E32B ₁₆ (DD ₁₆),	1E3AA ₁₆ (79 ₁₆),	1E3AB ₁₆ (70 ₁₆),
1E42A ₁₆ (20 ₁₆),	1E42B ₁₆ (82 ₁₆),	1E4AA ₁₆ (24 ₁₆),	1E4AB ₁₆ (02 ₁₆),	1E52A ₁₆ (04 ₁₆),	1E52B ₁₆ (12 ₁₆),	1E5AA ₁₆ (00 ₁₆),	1E5AB ₁₆ (90 ₁₆),
1E62A ₁₆ (92 ₁₆),	1E62B ₁₆ (00 ₁₆),	1E6AA ₁₆ (10 ₁₆),	1E6AB ₁₆ (41 ₁₆),	1E72A ₁₆ (90 ₁₆),	1E72B ₁₆ (48 ₁₆),	1E7AA ₁₆ (90 ₁₆),	1E7AB ₁₆ (41 ₁₆),
1E82A ₁₆ (A9 ₁₆),	1E82B ₁₆ (C5 ₁₆),	1E8AA ₁₆ (E2 ₁₆),	1E8AB ₁₆ (5C ₁₆),	1E92A ₁₆ (41 ₁₆),	1E92B ₁₆ (EE ₁₆),	1E9AA ₁₆ (25 ₁₆),	1E9AB ₁₆ (79 ₁₆),
1EA2A ₁₆ (65 ₁₆),	1EA2B ₁₆ (E8 ₁₆),	1EAAA ₁₆ (2F ₁₆),	1EAAB ₁₆ (31 ₁₆),	1EB2A ₁₆ (72 ₁₆),	1EB2B ₁₆ (74 ₁₆),	1EBAA ₁₆ (AE ₁₆),	1EBAB ₁₆ (4C ₁₆),
1EC2A ₁₆ (A1 ₁₆),	1EC2B ₁₆ (60 ₁₆),	1ECAA ₁₆ (05 ₁₆),	1ECAB ₁₆ (22 ₁₆),	1ED2A ₁₆ (84 ₁₆),	1ED2B ₁₆ (68 ₁₆),	1EDAA ₁₆ (31 ₁₆),	1EDAB ₁₆ (6A ₁₆),
1EE2A ₁₆ (29 ₁₆),	1EE2B ₁₆ (22 ₁₆),	1EEAA ₁₆ (4D ₁₆),	1EEAB ₁₆ (A0 ₁₆),	1EF2A ₁₆ (61 ₁₆),	1EF2B ₁₆ (04 ₁₆),	1EFAA ₁₆ (09 ₁₆),	1EFAB ₁₆ (92 ₁₆),
1F02A ₁₆ (4F ₁₆),	1F02B ₁₆ (A6 ₁₆),	1F0AA ₁₆ (D2 ₁₆),	1F0AB ₁₆ (2F ₁₆),	1F12A ₁₆ (BB ₁₆),	1F12B ₁₆ (60 ₁₆),	1F1AA ₁₆ (38 ₁₆),	1F1AB ₁₆ (A5 ₁₆),
1F22A ₁₆ (85 ₁₆),	1F22B ₁₆ (B8 ₁₆),	1F2AA ₁₆ (19 ₁₆),	1F2AB ₁₆ (93 ₁₆),	1F32A ₁₆ (4F ₁₆),	1F32B ₁₆ (0D ₁₆),	1F3AA ₁₆ (E6 ₁₆),	1F3AB ₁₆ (83 ₁₆),
1F42A ₁₆ (F6 ₁₆),	1F42B ₁₆ (18 ₁₆),	1F4AA ₁₆ (86 ₁₆),	1F4AB ₁₆ (2F ₁₆),	1F52A ₁₆ (6C ₁₆),	1F52B ₁₆ (AC ₁₆),	1F5AA ₁₆ (D8 ₁₆),	1F5AB ₁₆ (4D ₁₆),
1F62A ₁₆ (52 ₁₆),	1F62B ₁₆ (6D ₁₆),	1F6AA ₁₆ (1B ₁₆),	1F6AB ₁₆ (AA ₁₆),	1F72A ₁₆ (B3 ₁₆),	1F72B ₁₆ (43 ₁₆),	1F7AA ₁₆ (C3 ₁₆),	1F7AB ₁₆ (99 ₁₆),
1F82A ₁₆ (68 ₁₆),	1F82B ₁₆ (E5 ₁₆),	1F8AA ₁₆ (E9 ₁₆),	1F8AB ₁₆ (98 ₁₆),	1F92A ₁₆ (8C ₁₆),	1F92B ₁₆ (8F ₁₆),	1F9AA ₁₆ (D9 ₁₆),	1F9AB ₁₆ (26 ₁₆),
1FA2A ₁₆ (D8 ₁₆),	1FA2B ₁₆ (47 ₁₆),	1FAAA ₁₆ (57 ₁₆),	1FAAB ₁₆ (C2 ₁₆),	1FB2A ₁₆ (DD ₁₆),	1FB2B ₁₆ (18 ₁₆),	1FBAA ₁₆ (96 ₁₆),	1FBAB ₁₆ (36 ₁₆),

<"2A16"> address (test data)

1D45A ₁₆ (51 ₁₆),	1D455 ₁₆ (10 ₁₆),	1D4D4 ₁₆ (03 ₁₆),	1D4D5 ₁₆ (50 ₁₆),	1D554 ₁₆ (93 ₁₆),	1D555 ₁₆ (00 ₁₆),	1D5D4 ₁₆ (90 ₁₆),	1D5D5 ₁₆ (08 ₁₆),
1D65A ₁₆ (0B ₁₆),	1D655 ₁₆ (04 ₁₆),	1D6D4 ₁₆ (82 ₁₆),	1D6D5 ₁₆ (14 ₁₆),	1D754 ₁₆ (41 ₁₆),	1D755 ₁₆ (14 ₁₆),	1D7D4 ₁₆ (8A ₁₆),	1D7D5 ₁₆ (14 ₁₆),
1D85A ₁₆ (E8 ₁₆),	1D855 ₁₆ (00 ₁₆),	1D8D4 ₁₆ (A0 ₁₆),	1D8D5 ₁₆ (50 ₁₆),	1D954 ₁₆ (60 ₁₆),	1D955 ₁₆ (90 ₁₆),	1D9D4 ₁₆ (A8 ₁₆),	1D9D5 ₁₆ (50 ₁₆),
1DA5A ₁₆ (30 ₁₆),	1DA55 ₁₆ (24 ₁₆),	1DAD4 ₁₆ (10 ₁₆),	1DAD5 ₁₆ (A8 ₁₆),	1DB54 ₁₆ (32 ₁₆),	1DB55 ₁₆ (08 ₁₆),	1DBD4 ₁₆ (22 ₁₆),	1DBD5 ₁₆ (01 ₁₆),
1DC5A ₁₆ (01 ₁₆),	1DC55 ₁₆ (C2 ₁₆),	1DCD4 ₁₆ (09 ₁₆),	1DCD5 ₁₆ (41 ₁₆),	1DD54 ₁₆ (09 ₁₆),	1DD55 ₁₆ (84 ₁₆),	1DDD4 ₁₆ (09 ₁₆),	1DDD5 ₁₆ (A2 ₁₆),
1DE5A ₁₆ (87 ₁₆),	1DE55 ₁₆ (00 ₁₆),	1DED4 ₁₆ (25 ₁₆),	1DED5 ₁₆ (20 ₁₆),	1DF54 ₁₆ (8C ₁₆),	1DF55 ₁₆ (20 ₁₆),	1DFD4 ₁₆ (29 ₁₆),	1DFD5 ₁₆ (00 ₁₆),
1E05A ₁₆ (10 ₁₆),	1E055 ₁₆ (89 ₁₆),	1E0D4 ₁₆ (10 ₁₆),	1E0D5 ₁₆ (A2 ₁₆),	1E154 ₁₆ (10 ₁₆),	1E155 ₁₆ (1A ₁₆),	1E1D4 ₁₆ (00 ₁₆),	1E1D5 ₁₆ (B0 ₁₆),
1E25A ₁₆ (44 ₁₆),	1E255 ₁₆ (44 ₁₆),	1E2D4 ₁₆ (25 ₁₆),	1E2D5 ₁₆ (40 ₁₆),	1E354 ₁₆ (49 ₁₆),	1E355 ₁₆ (40 ₁₆),	1E3D4 ₁₆ (C1 ₁₆),	1E3D5 ₁₆ (44 ₁₆),
1E45A ₁₆ (02 ₁₆),	1E455 ₁₆ (52 ₁₆),	1E4D4 ₁₆ (22 ₁₆),	1E4D5 ₁₆ (41 ₁₆),	1E554 ₁₆ (00 ₁₆),	1E555 ₁₆ (71 ₁₆),	1E5D4 ₁₆ (20 ₁₆),	1E5D5 ₁₆ (03 ₁₆),
1E65A ₁₆ (58 ₁₆),	1E655 ₁₆ (10 ₁₆),	1E6D4 ₁₆ (2A ₁₆),	1E6D5 ₁₆ (14 ₁₆),	1E754 ₁₆ (64 ₁₆),	1E755 ₁₆ (14 ₁₆),	1E7D4 ₁₆ (4C ₁₆),	1E7D5 ₁₆ (18 ₁₆),
1E85A ₁₆ (21 ₁₆),	1E855 ₁₆ (61 ₁₆),	1E8D4 ₁₆ (24 ₁₆),	1E8D5 ₁₆ (25 ₁₆),	1E954 ₁₆ (24 ₁₆),	1E955 ₁₆ (42 ₁₆),	1E9D4 ₁₆ (60 ₁₆),	1E9D5 ₁₆ (62 ₁₆),
1EA5A ₁₆ (8B ₁₆),	1EA55 ₁₆ (00 ₁₆),	1EAD4 ₁₆ (88 ₁₆),	1EAD5 ₁₆ (41 ₁₆),	1EB54 ₁₆ (92 ₁₆),	1EB55 ₁₆ (01 ₁₆),	1EBD4 ₁₆ (01 ₁₆),	1EBD5 ₁₆ (41 ₁₆),
1EC5A ₁₆ (80 ₁₆),	1EC55 ₁₆ (4C ₁₆),	1ECD4 ₁₆ (06 ₁₆),	1ECD5 ₁₆ (0C ₁₆),	1ED54 ₁₆ (82 ₁₆),	1ED55 ₁₆ (14 ₁₆),	1EDD4 ₁₆ (14 ₁₆),	1EDD5 ₁₆ (4C ₁₆),
1EE5A ₁₆ (62 ₁₆),	1EE55 ₁₆ (20 ₁₆),	1EED4 ₁₆ (C6 ₁₆),	1EED5 ₁₆ (00 ₁₆),	1EF54 ₁₆ (AA ₁₆),	1EF55 ₁₆ (00 ₁₆),	1EFD4 ₁₆ (A8 ₁₆),	1EFD5 ₁₆ (00 ₁₆),
1F05A ₁₆ (83 ₁₆),	1F055 ₁₆ (09 ₁₆),	1F0D4 ₁₆ (02 ₁₆),	1F0D5 ₁₆ (1B ₁₆),	1F154 ₁₆ (01 ₁₆),	1F155 ₁₆ (4B ₁₆),	1F1D4 ₁₆ (01 ₁₆),	1F1D5 ₁₆ (43 ₁₆),
1F25A ₁₆ (34 ₁₆),	1F255 ₁₆ (02 ₁₆),	1F2D4 ₁₆ (A8 ₁₆),	1F2D5 ₁₆ (02 ₁₆),	1F354 ₁₆ (18 ₁₆),	1F355 ₁₆ (0A ₁₆),	1F3D4 ₁₆ (A6 ₁₆),	1F3D5 ₁₆ (02 ₁₆),
1F45A ₁₆ (08 ₁₆),	1F455 ₁₆ (26 ₁₆),	1F4D4 ₁₆ (08 ₁₆),	1F4D5 ₁₆ (1C ₁₆),	1F554 ₁₆ (08 ₁₆),	1F555 ₁₆ (70 ₁₆),	1F5D4 ₁₆ (00 ₁₆),	1F5D5 ₁₆ (2C ₁₆),
1F65A ₁₆ (A4 ₁₆),	1F655 ₁₆ (10 ₁₆),	1F6D4 ₁₆ (8D ₁₆),	1F6D5 ₁₆ (02 ₁₆),	1F754 ₁₆ (98 ₁₆),	1F755 ₁₆ (12 ₁₆),	1F7D4 ₁₆ (B8 ₁₆),	1F7D5 ₁₆ (80 ₁₆),
1F85A ₁₆ (94 ₁₆),	1F855 ₁₆ (20 ₁₆),	1F8D4 ₁₆ (B0 ₁₆),	1F8D5 ₁₆ (80 ₁₆),	1F954 ₁₆ (84 ₁₆),	1F955 ₁₆ (84 ₁₆),	1F9D4 ₁₆ (80 ₁₆),	1F9D5 ₁₆ (A6 ₁₆),
1FA5A ₁₆ (34 ₁₆),	1FA55 ₁₆ (04 ₁₆),	1FAD4 ₁₆ (B0 ₁₆),	1FAD5 ₁₆ (80 ₁₆),	1FB54 ₁₆ (22 ₁₆),	1FB55 ₁₆ (84 ₁₆),	1FBD4 ₁₆ (90 ₁₆),	1FBD5 ₁₆ (04 ₁₆),

2 : The character code of "09₁₆" is premised on using it as a character of "transparent space".
 Therefore, set "00₁₆" to the 40-byte addresses corresponding to the character code "09₁₆."

<Transparent space font data storing area>
 addresses 11000₁₆ + (4 + 2n) × 100₁₆ + 12₁₆ to
 11000₁₆ + (4 + 2n) × 100₁₆ + 13₁₆
 (n = 0 to 19)

addresses 11412 ₁₆ and 11413 ₁₆
addresses 11612 ₁₆ and 11613 ₁₆
⋮
addresses 13812 ₁₆ and 13813 ₁₆
addresses 13A12 ₁₆ and 13A13 ₁₆

(2) OSD RAM

The RAM for OSD is allocated at addresses 0800₁₆ to 087F₁₆, and is divided into a display character code specification part, and a color code specification part per block. Table 8.10.2 shows the contents of the OSD RAM.

For example, to display the first character position (the left edge) in block 1, write the character code in address 0800₁₆, and write the color code at 0820₁₆.

The structure of the OSD RAM is shown in Figure 8.10.17.

Table 8.10.2 Contents of OSD RAM

Block	Display Position (from left)	Character Code Specification	Color Code Specification
Block 1	1st character	0800 ₁₆	0820 ₁₆
	2nd character	0801 ₁₆	0821 ₁₆
	3rd character	0802 ₁₆	0822 ₁₆
	⋮	⋮	⋮
	30th character	081D ₁₆	083D ₁₆
	31st character	081E ₁₆	083E ₁₆
Block 2	32nd character	081F ₁₆	083F ₁₆
	1st character	0840 ₁₆	0860 ₁₆
	2nd character	0841 ₁₆	0861 ₁₆
	3rd character	0842 ₁₆	0862 ₁₆
	⋮	⋮	⋮
	30th character	085D ₁₆	087D ₁₆
Block 2	31st character	085E ₁₆	087E ₁₆
	32nd character	085F ₁₆	087F ₁₆

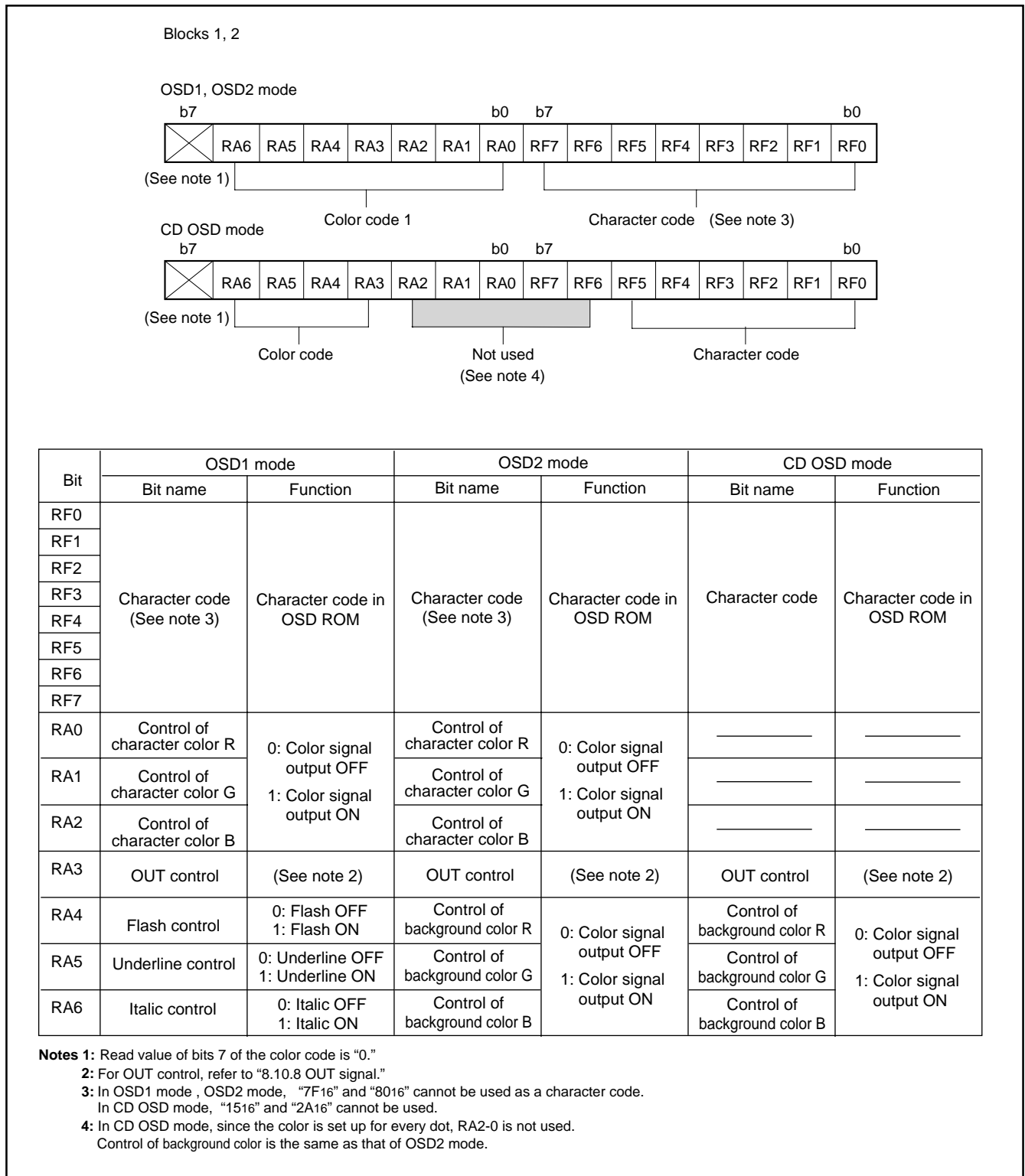

Fig. 8.10.17 Bit structure of OSD RAM

8.10.6 Character color

The color for each character is displayed by the color code.
The 7 kinds of color are specified by bits 4 (R), 5 (G), and 6 (B) of the color code.

8.10.7 Character background color

The character background color can be displayed in the character display area only in the OSD2,CD OSD mode. The character background color for each character is specified by the color code.
The 7 kinds of color are specified by bits 4 (R), 5 (G), and 6 (B) of the color code.

Note : The character background color is displayed in the following parts :
(character display area)–(character font)–(border).
Accordingly, the character background color does not mix with these color signals.

8.10.8 OUT signal

The OUT signal is used to control the luminance of the video signal. The output waveform of the OUT signal is controlled by RA3 of the OSD RAM. The setting values for controlling OUT and the corresponding output waveform are shown in Figure 8.10.18.

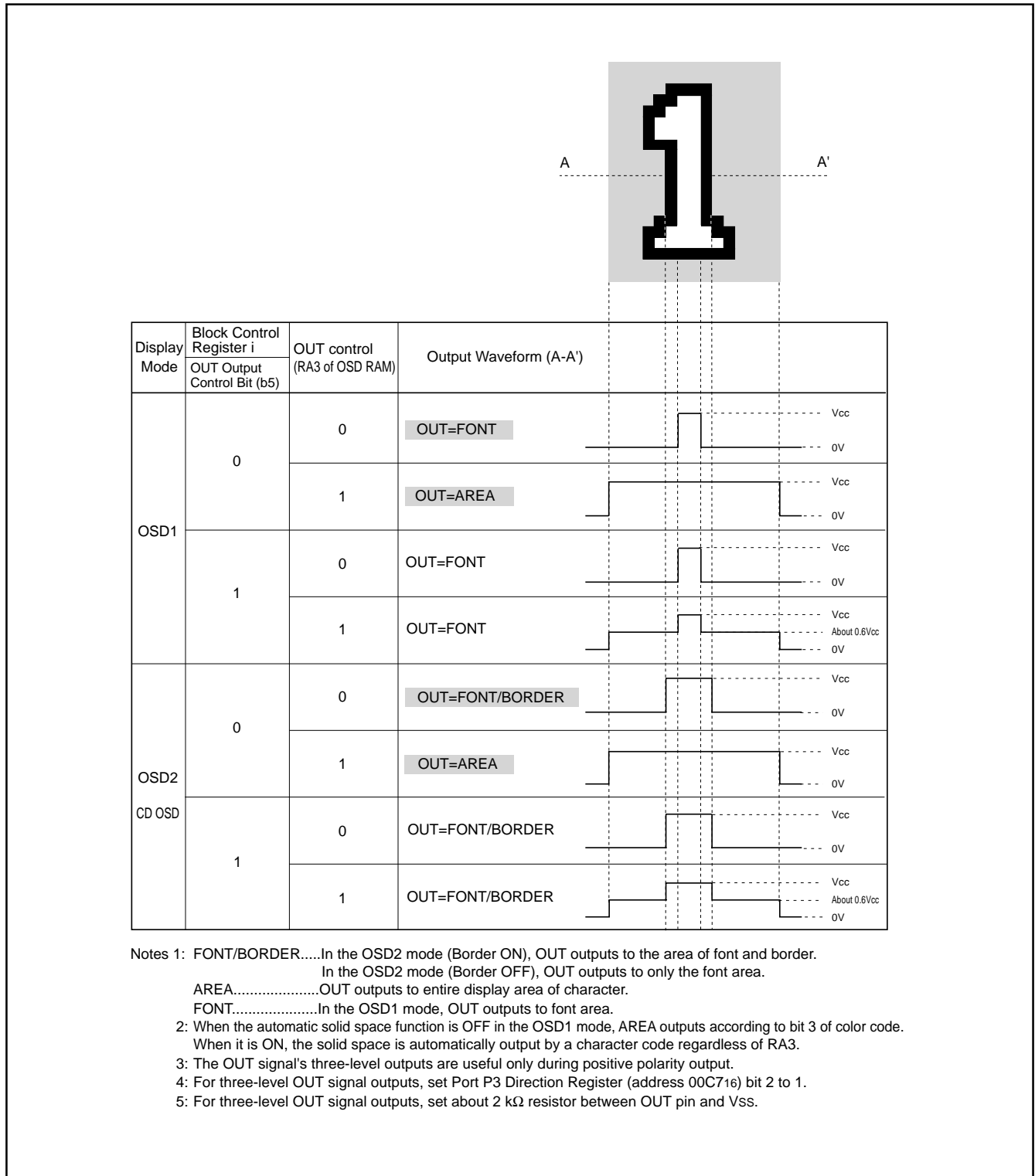

Fig. 8.10.18 Setting Value for Controlling OUT and Corresponding Output Waveform

8.10.9 Attribute

The attributes (border, flash, underline, italic) are controlled according to the character font. The attributes to be controlled are different depending on each mode.

OSD1 mode Flash, underline, italic (per character unit)

OSD2 mode Border (per character unit)

(1) Under line

The underline is output at the 23th and 24th dots in the vertical direction only in the OSD1 mode. The underline is controlled by RA5 of the OSD RAM. The color of the underline is the same color as that of the character font.

(2) Flash

The character font and the underline are flashed only in the OSD1 mode. The flash is controlled by RA4 of OSD RAM. In the character font part, the character output part is flashed, but the character background part is not flashed. The flash cycle is based on the VSYNC count.

- VSYNC cycle X 48 ≈ 800 ms (at display ON)
- VSYNC cycle X 16 ≈ 267 ms (at display OFF)

(3) Italic

The italic is made by slanting the font stored in the OSD ROM to the right only in the OSD1 mode. The italic is controlled by RA6 of OSD RAM.

Display examples of the italic and underline are shown in Figure 8.10.19, using, "R."

- Notes**
- 1: When setting both the italic and the flash, the italic character flashes.
 - 2: The boundary of character color is displayed in italic. However, the boundary of character background color is not affected by the italic (refer to Figure 8.10.20).
 - 3: The adjacent character (one side or both sides) to an italic character is displayed in italic even when the character is not specified to be displayed in italic (refer to Figure 8.10.20).
 - 4: An italics display cannot be used in the pre-divide ratio 1.

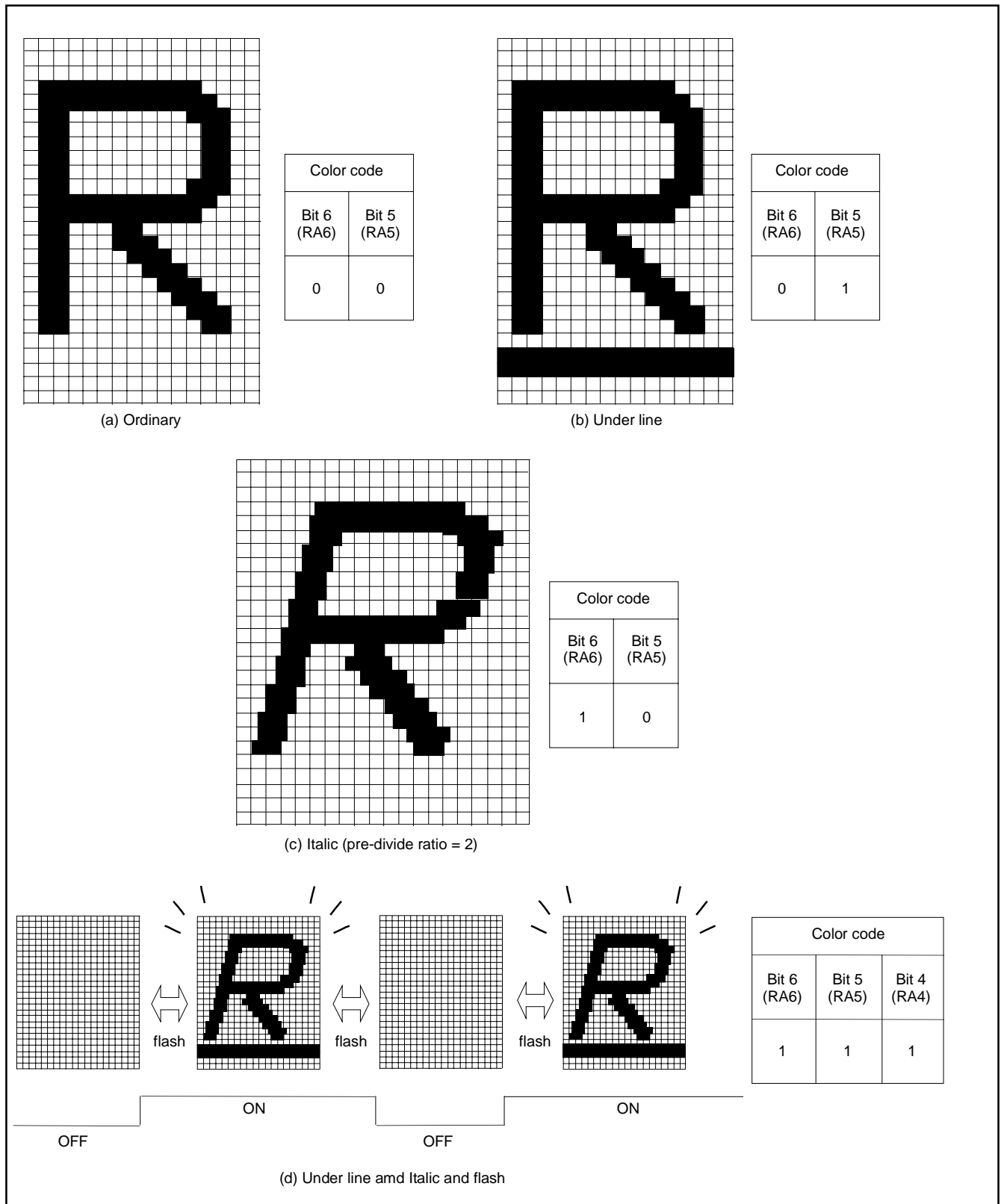

Fig. 8.10.19 Example of Attribute Display (in OSD1 Mode)

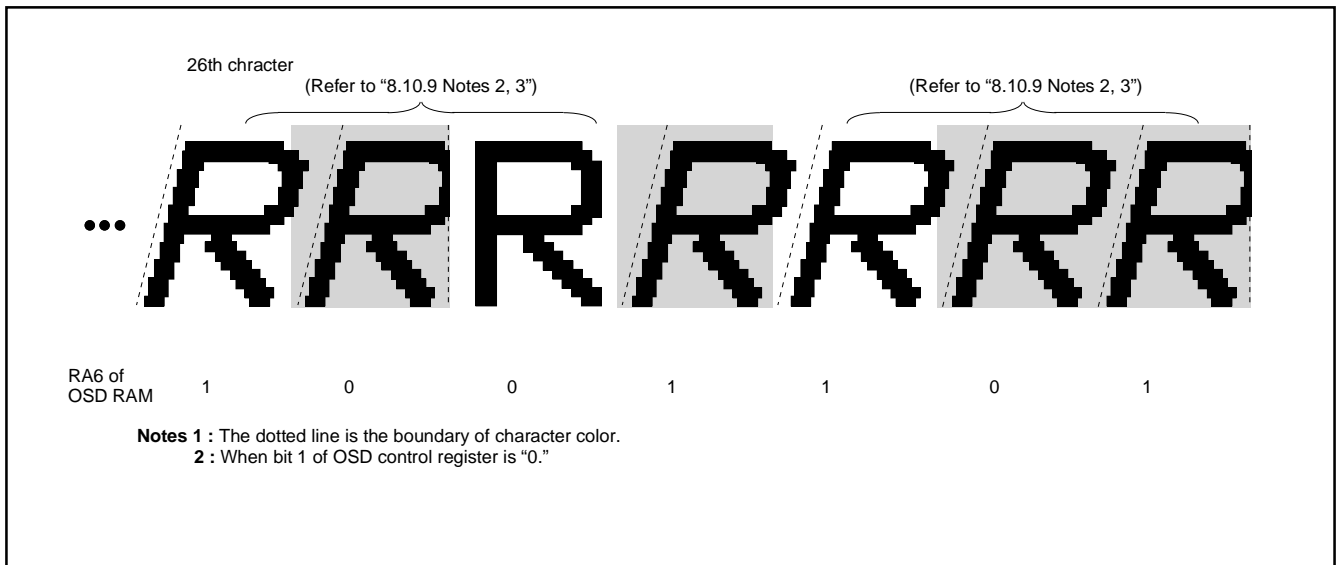

Fig. 8.10.20 Example of Italic Display

(4) Border

The border is output around the character font (all bordered) in the OSD2 mode only. The border ON/OFF is controlled by bit 0 and 1 of block control register i (refer to Figure 8.10.4).

The OUT signal is used for border output.

The horizontal size (x) of the border is 1Tc (OSD clock cycle divided in pre-divide circuit) regardless of the character font dot size. The vertical size (y) differs depending on the screen scan mode and the vertical dot size of the character font.

Notes 1 : The border dot area is the shaded area as shown in Figure 8.10.21.

2 : When the border dot overlaps on the next character font, the character font has priority (refer to Figure 8.10.23 A).

When the border dot overlaps the next character back ground, the border has priority (refer to Figure 8.10.23 B).

3 : The border in vertical out of the character area is not displayed (refer to Figure 8.10.23).

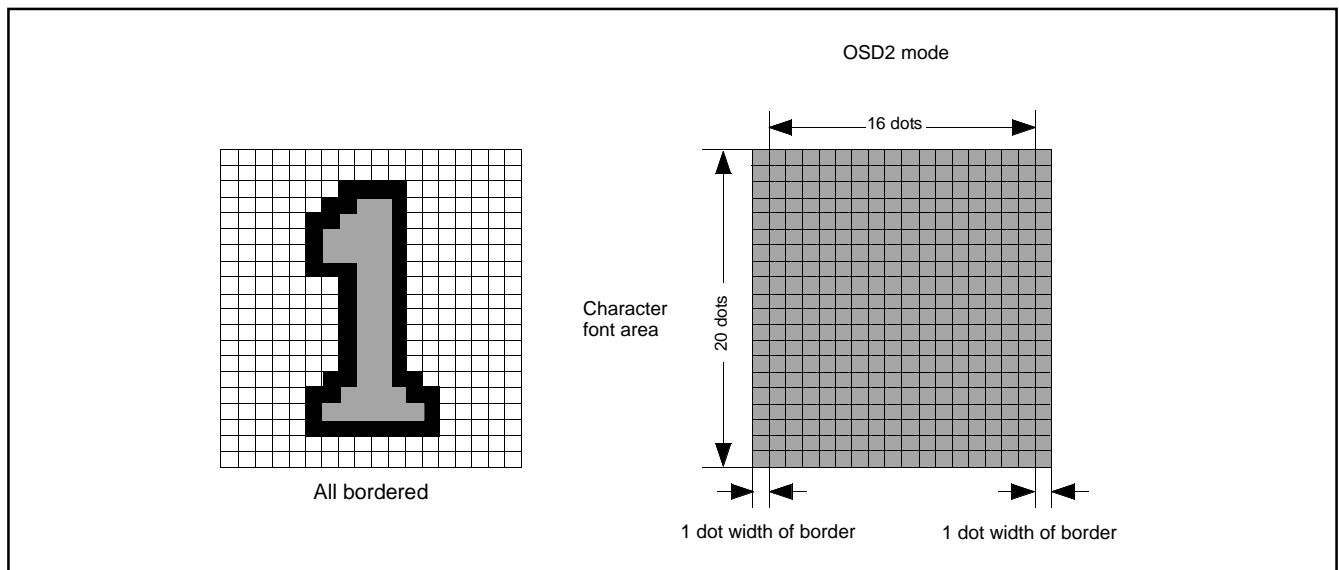

Fig. 8.10.21 Example of Border Display

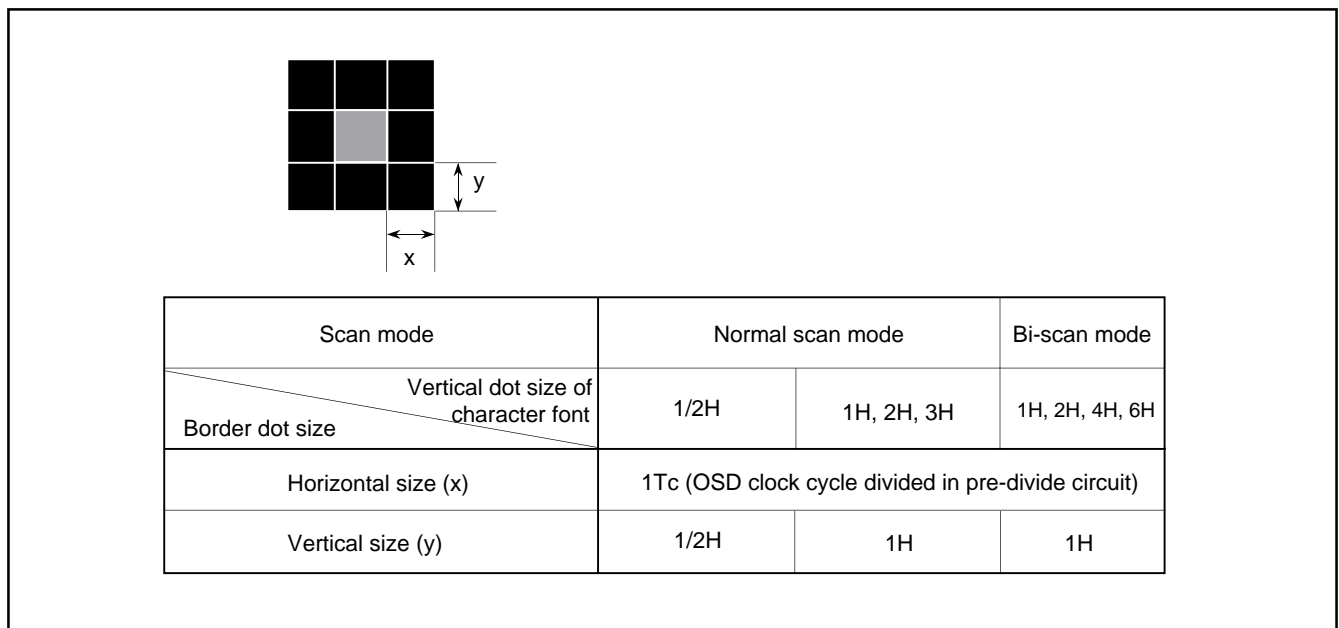

Fig. 8.10.22 Horizontal and Vertical Size of Border

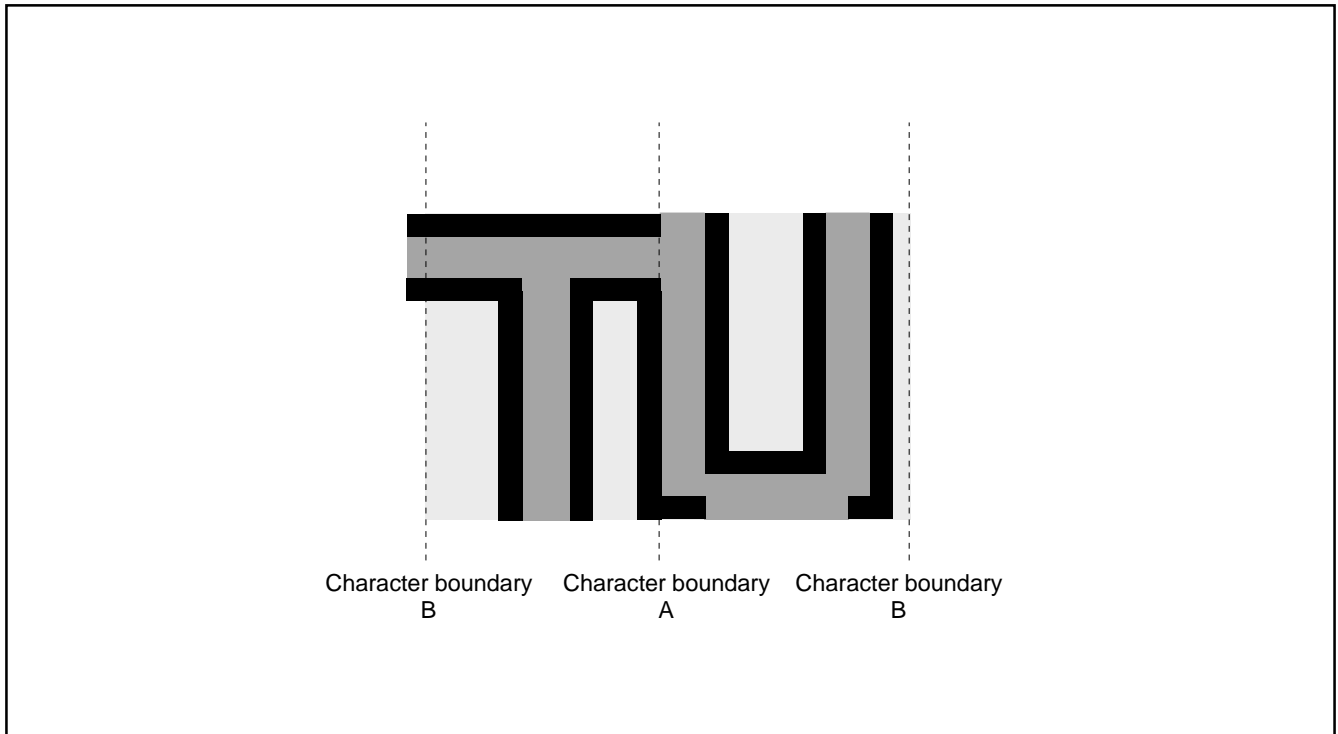

Fig. 8.10.23 Border Priority

8.10.10 Multiline Display

This microcomputer can ordinarily display 2 lines on the CRT screen by displaying 2 blocks at different vertical positions. In addition, it can display up to 16 lines by using OSD interrupts.

An OSD interrupt request occurs at the point at which that display of each block has been completed. In other words, when a scanning line reaches the point of the display position (specified by the vertical position registers) of a certain block, the character display of that block starts, and an interrupt occurs at the point at which the scanning line exceeds the block.

- Notes 1:** An OSD interrupt does not occur at the end of display when the block is not displayed. In other words, if a block is set to display OFF by the display control bit of the block control register (addresses 00D216, 00D316), an OSD interrupt request does not occur (refer to Figure 8.10.24 (A)).
- 2:** When another block display appears while one block is displayed, an OSD interrupt request occurs only once at the end of the second block display (refer to Figure 8.10.24 (B)).
- 3:** On the screen setting window, an OSD interrupt occurs even at the end of the OSD1 mode block (display OFF) out of window (refer to Figure 8.10.24(C)).

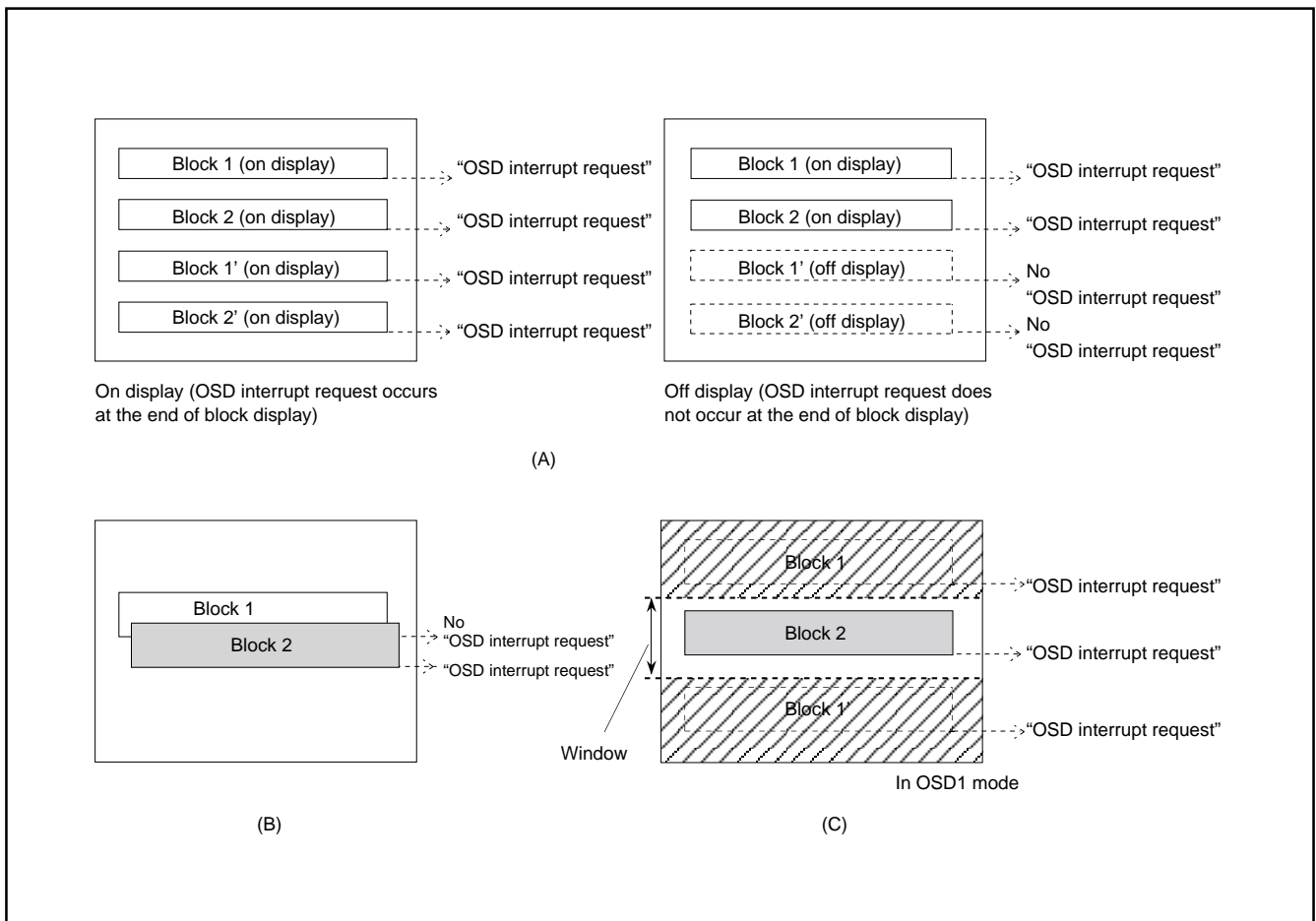

Fig. 8.10.24 Note on Occurrence of OSD Interrupt

8.10.11 Automatic Solid Space Function

This function automatically generates the solid space (OUT blank output) of the character area in the OSD1 mode.

The solid space is output in the following areas :

- Any character area except character code "09₁₆"
- Character area on the left and right sides of the above character

This function is turned on and off by bit 1 of the OSD control register (refer to Figure 8.10.3).

Notes : The character code "09₁₆" is used for "transparent space". Therefore, set "00₁₆" to the 40-byte addresses corresponding to the character code "09₁₆".

<Transparent space font data storing area>
 addresses 11000₁₆ + (4 + 2n) × 100₁₆ + 12₁₆ to
 11000₁₆ + (4 + 2n) × 100₁₆ + 13₁₆
 (n = 0 to 19)

addresses 11412₁₆ and 11413₁₆
 addresses 11612₁₆ and 11613₁₆
 ⋮
 addresses 13812₁₆ and 13813₁₆
 addresses 13A12₁₆ and 13A13₁₆

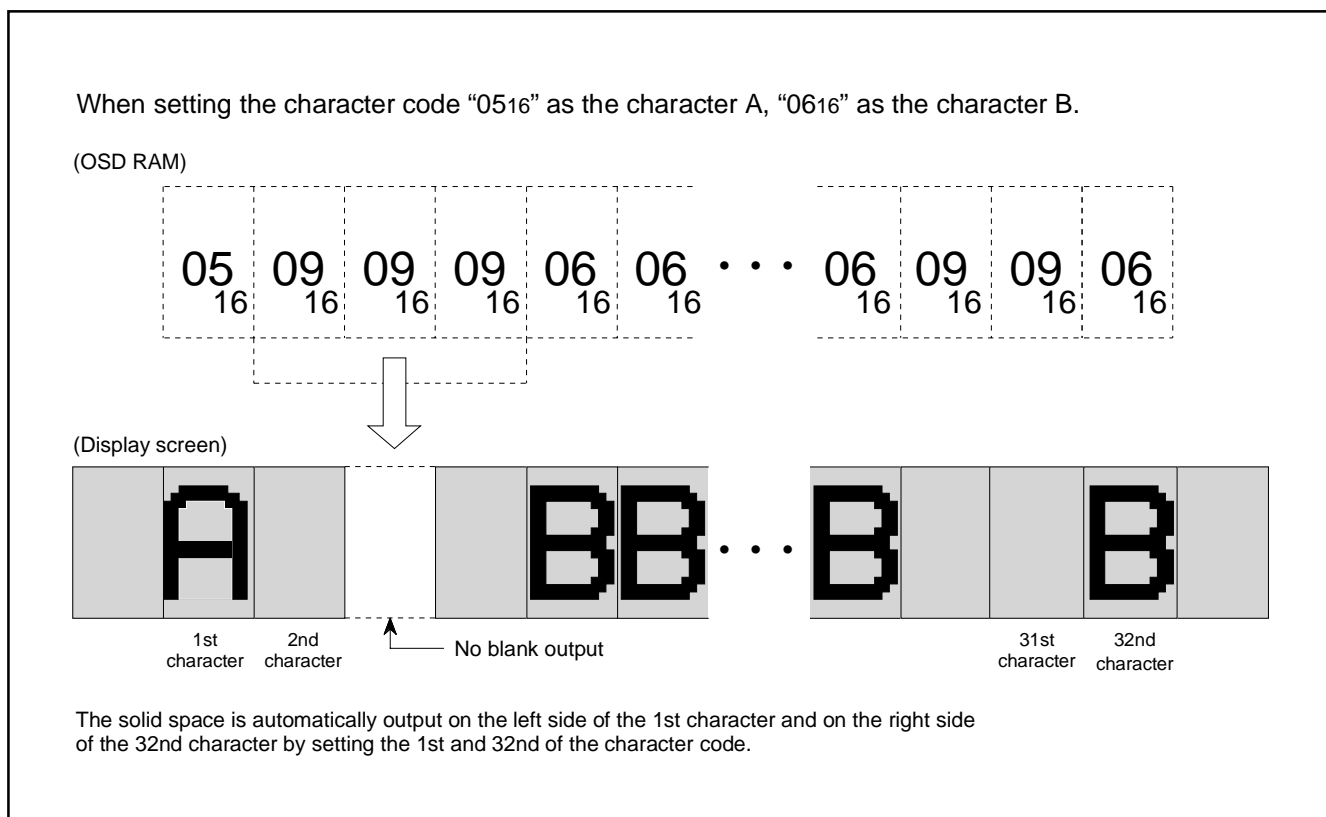

Fig. 8.10.25 Display Screen Example of Automatic Solid Space

8.10.12 Scan mode

The Bi-scan mode corresponds to HSYNC of twice as much frequency as usual. The vertical display position and the vertical dot size double compared to the normal scan mode. Scan mode can be set the vertical dot size in bit 0 of OSD control register 2, and the vertical display start position in bit 1, independently .

Table 8.10.3 Setting of Scan Mode

Item	Scan mode	Normal scan	Bi-scan
Bit 0 of OSD control register 2		0	1
Vertical dot size		1Tc X 1/2H 1Tc X 1H 2Tc X 2H 3Tc X 3H	1Tc X 1H 1Tc X 2H 2Tc X 4H 3Tc X 6H
Bit 1 of OSD control register 2		0	1
Vertical display start position		A value of vertical position register X 1H	A value of vertical position register X 2H

8.10.13 Window Function

This function sets the top and bottom boundaries for display limits on a screen. The window function is valid only in the OSD1 mode. The top boundary is set by the window register 1 and bit 7 of block control register 1. The bottom boundary is set by window register 1 and bit 7 of block control register 2. This function is turned on and off by bit 2 of the OSD control register (refer to Figure 8.10.3). Window registers 1 and 2 are shown in Figures 8.10.27 and 8.10.28.

The setting value per one step of the top and bottom window borders can be switched to either 1TH or 2TH by setting "0" or "1" to bit 1 of OSD control register 2 (address 02DB16).

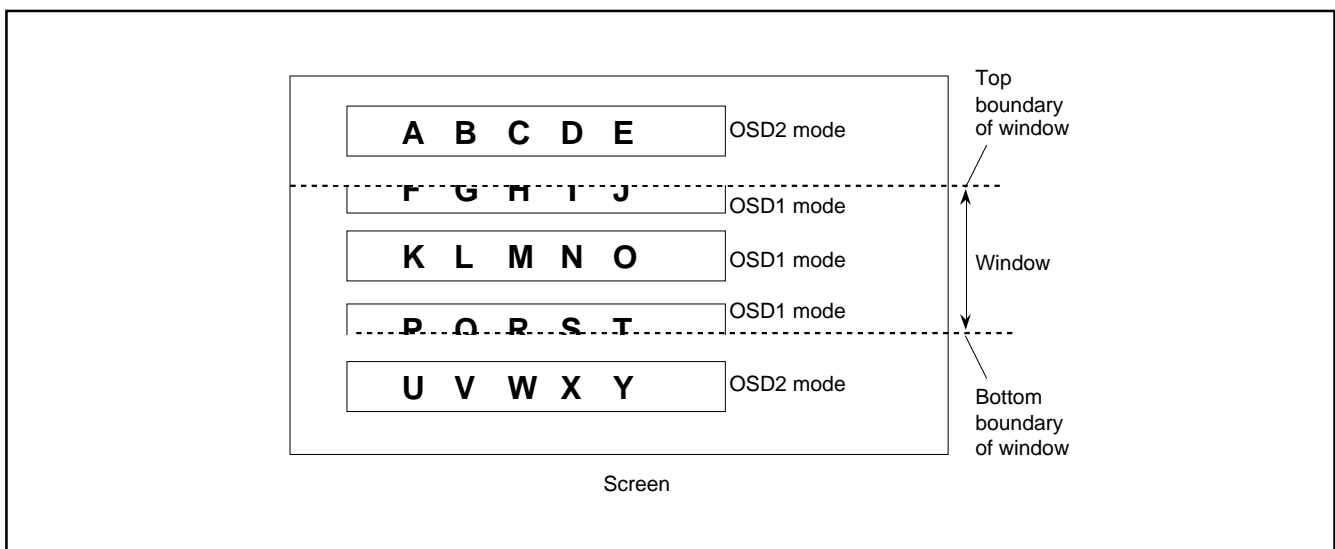

Fig. 8.10.26 Example of Window Function

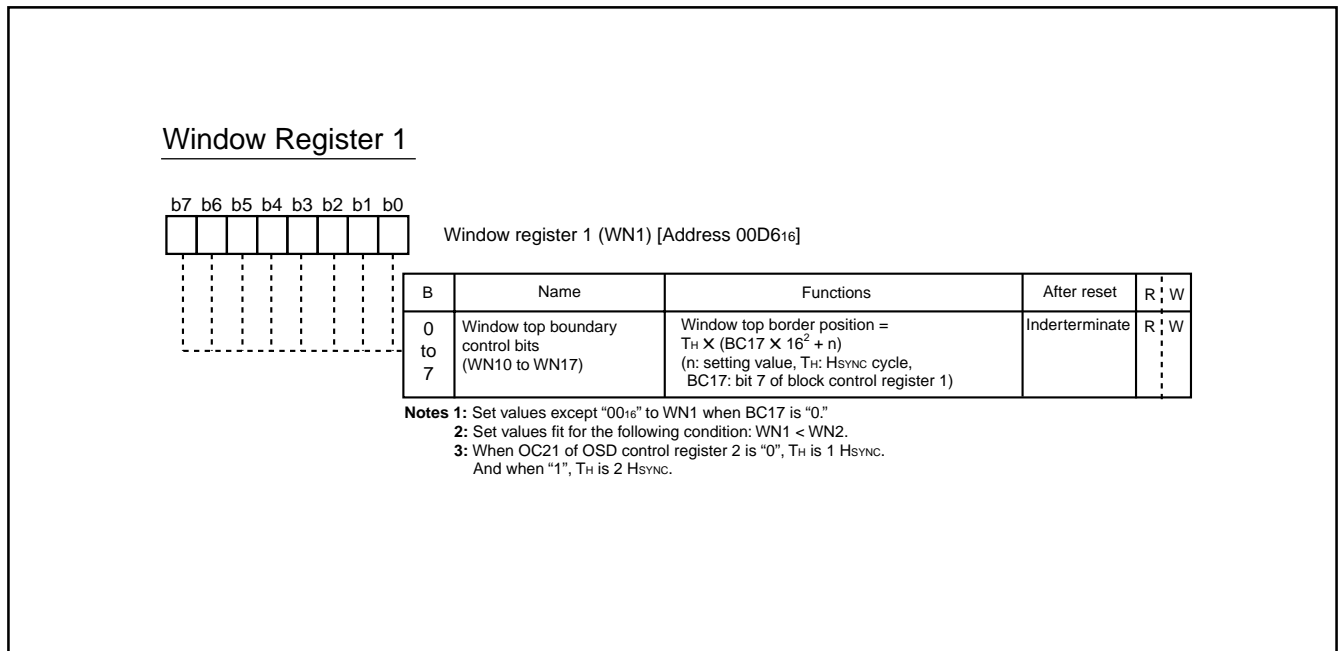

Fig. 8.10.27 Window Register 1

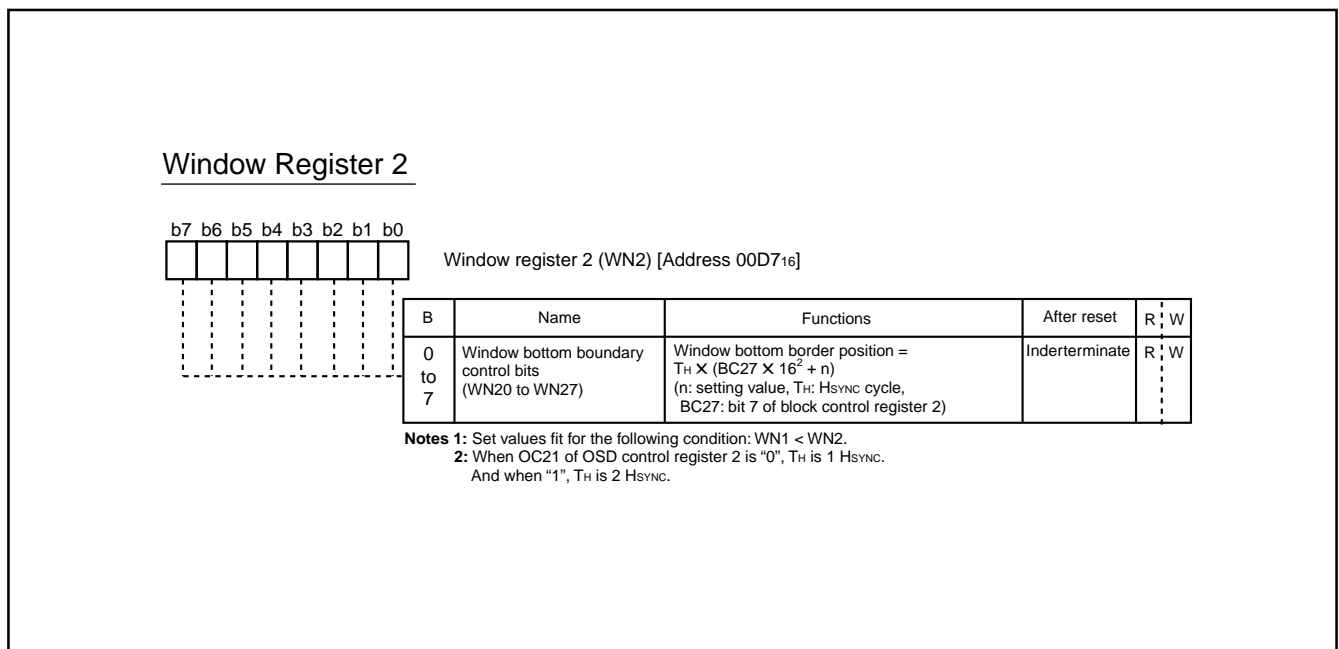

Fig. 8.10.28 Window Register 2

8.10.14 OSD Output Pin Control

The OSD output pins R, G, B and OUT can also function as ports P52–P55. Set the corresponding bit of the OSD port control register (address 00CB16) to “0” to specify these pins as OSD output pins, or to “1” to specify as the general-purpose port P5.

The input polarity of the HSYNC and VSYNC, and the output polarity of signals R, G, B, OUT can be specified with the I/O polarity control register (address 00D8.) Set bits to “0” to specify positive polarity; “1” to specify negative polarity (refer to Figure 8.10.13).

The structure of the OSD port control register is shown in Figure 8.10.29.

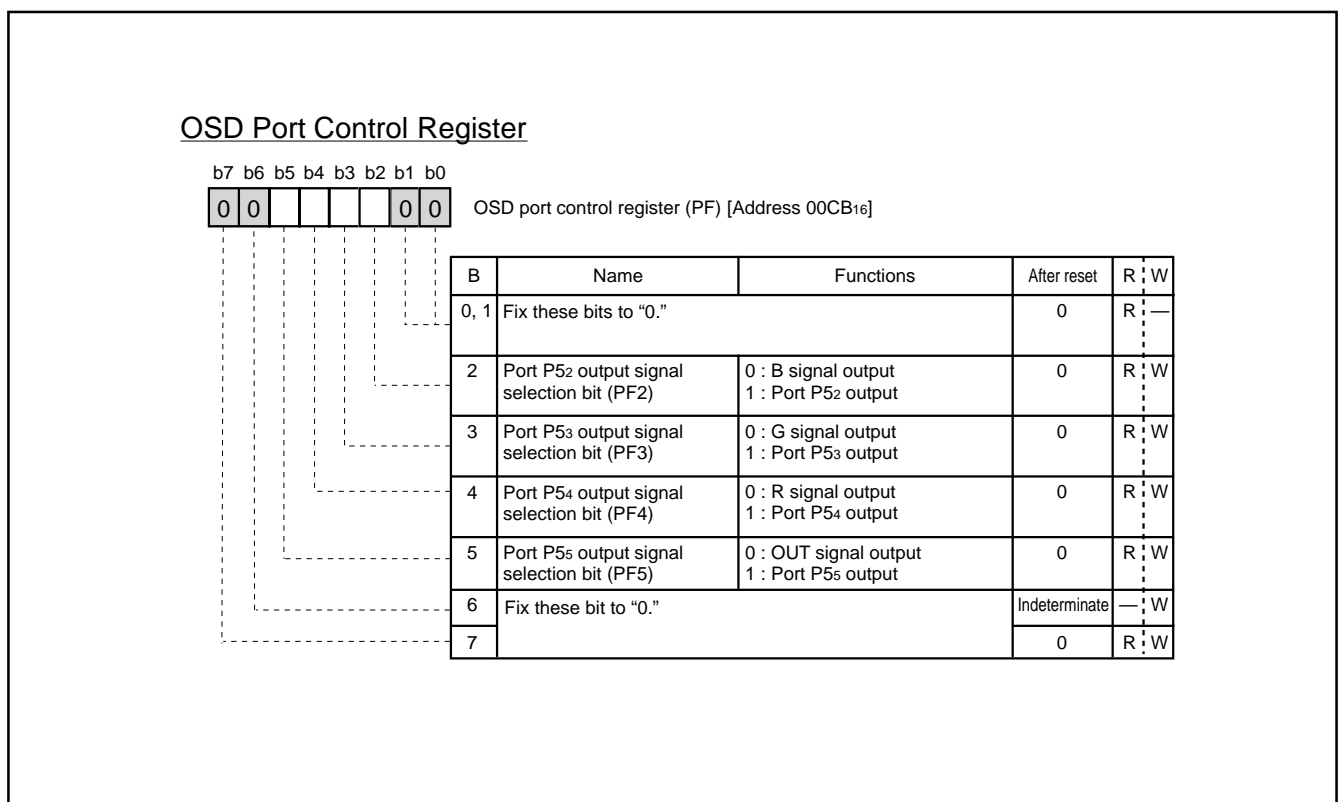

Fig. 8.10.29 OSD Port Control Register

8.10.15 Raster Coloring Function

An entire screen (raster) can be colored by setting bits 4 to 0 of the raster color register. Since each of the R, G, B, OUT pins can be switched to raster coloring output, 8 raster colors can be obtained.

When the character color character background color overlaps with the raster color, the color (R, G, B, OUT), specified for the character color character background color, takes priority over the raster color. This ensures that character color/character background color is not mixed with the raster color.

The raster color register is shown in Figure 8.10.31, an example of raster coloring is shown in Figure 8.10.30.

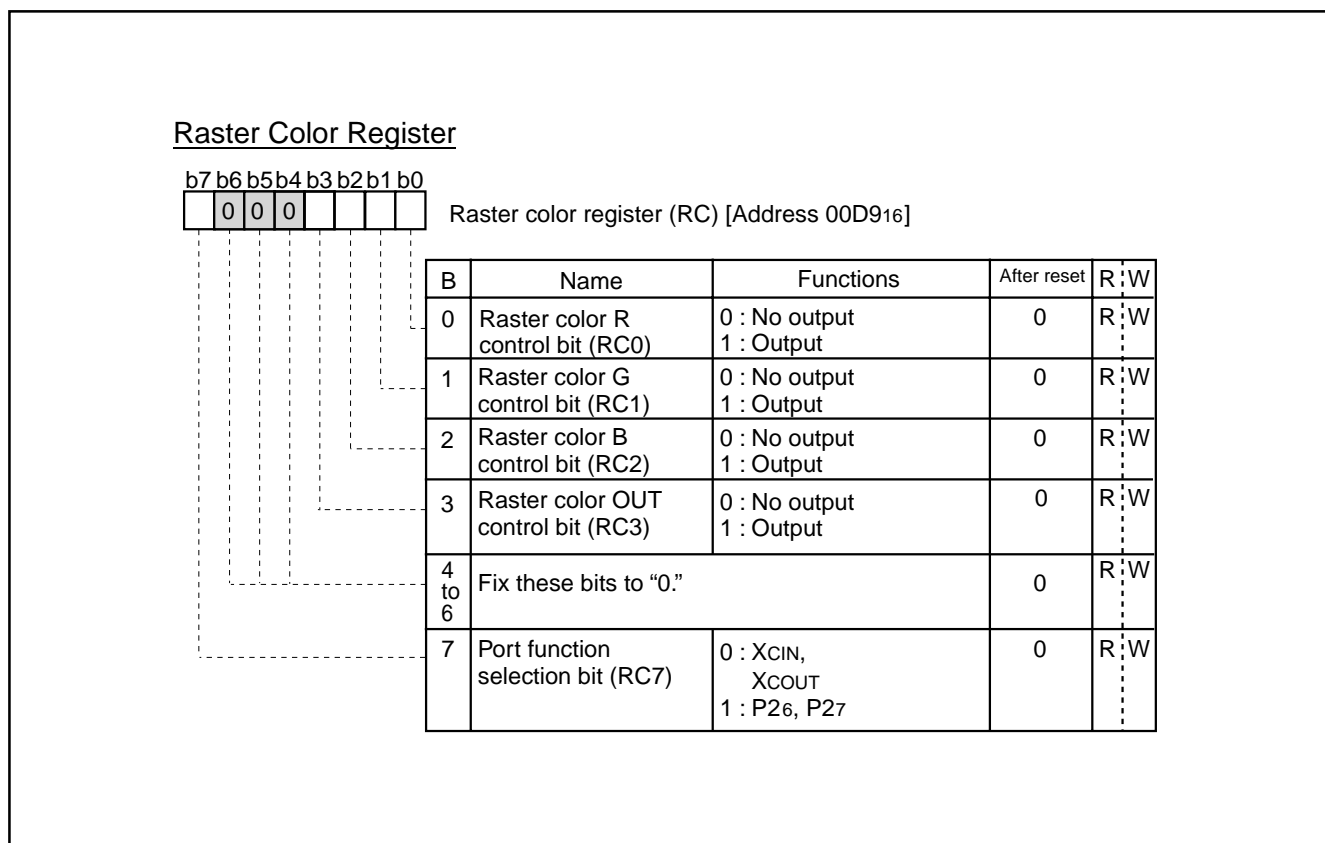

Fig. 8.10.30 Raster Color Register

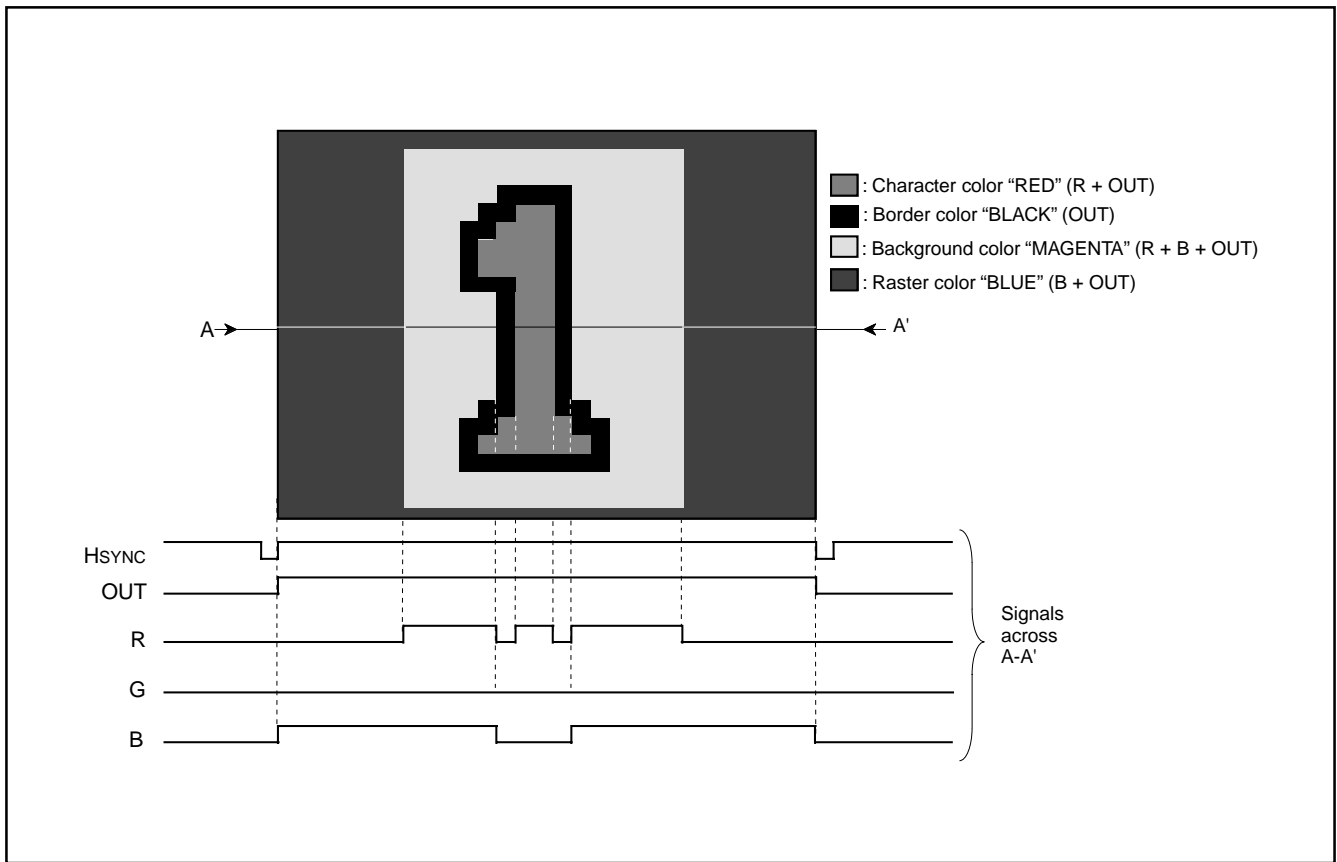

Fig. 8.10.31 Example of Raster Coloring

8.11 SOFTWARE RUNAWAY DETECT FUNCTION

This microcomputer has a function to decode undefined instructions to detect a software runaway.

When an undefined op-code is input to the CPU as an instruction code during operation, the following processing is done.

- ① The CPU generates an undefined instruction decoding signal.
- ② The device is internally reset due to the undefined instruction decoding signal.
- ③ As a result of internal reset, the same reset processing as in the case of ordinary reset operation is done, and the program restarts from the reset vector.

Note, however, that the software runaway detecting function cannot be disabled.

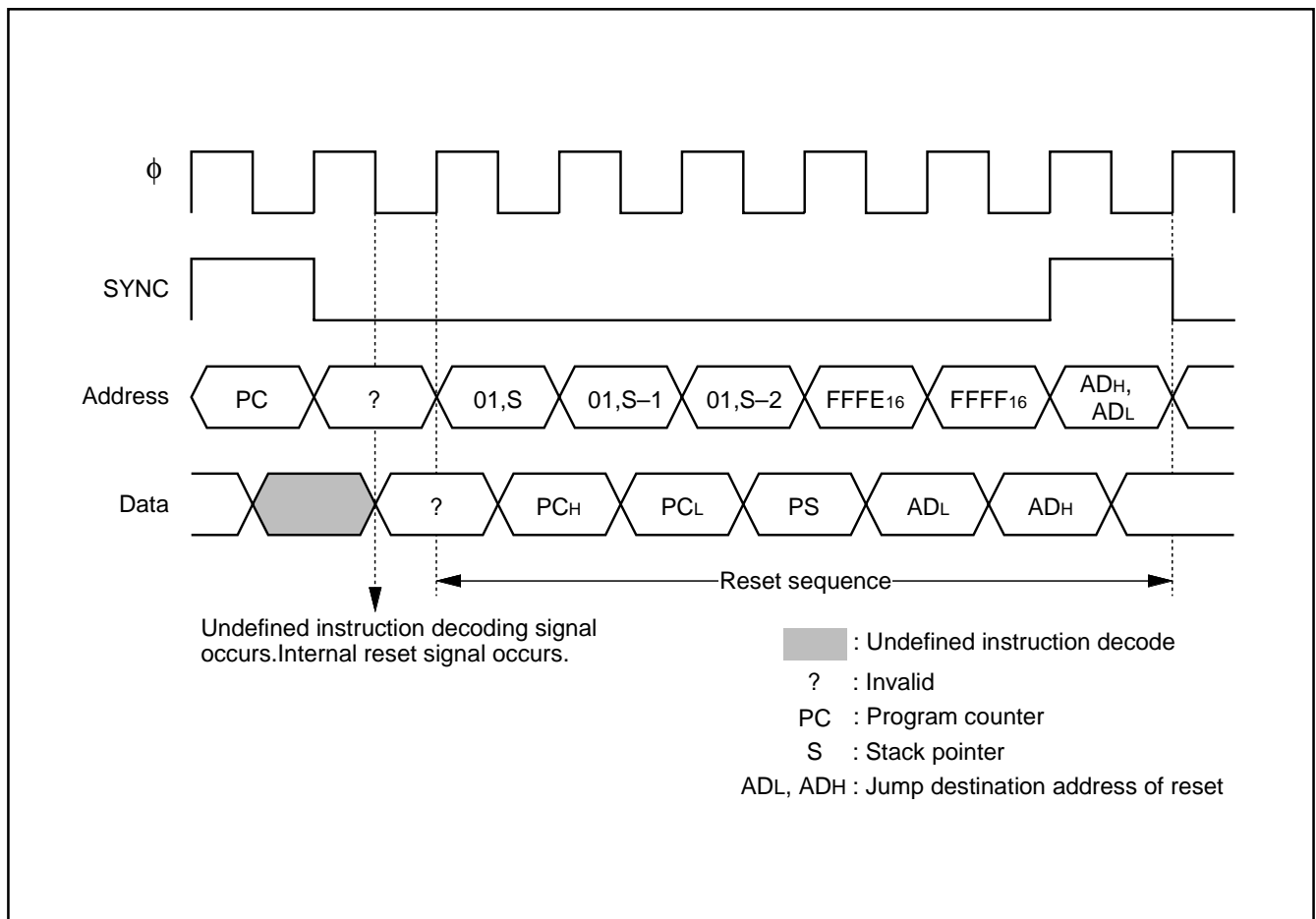

Fig.8.11.1 Sequence at Detecting Software Runaway Detection

8.12 RESET CIRCUIT

When the oscillation of a quartz-crystal oscillator or a ceramic resonator is stable and the power source voltage is $5\text{ V} \pm 10\%$, hold the $\overline{\text{RESET}}$ pin at LOW for $2\ \mu\text{s}$ or more, then return to HIGH. Then, as shown in Figure 8.12.2, reset is released and the program starts from the address formed by using the content of address FFFF_{16} as the high-order address and the content of the address FFFE_{16} as the low-order address. The internal states of the microcomputer at reset are shown in Figures 8.2.2 to 8.2.5.

An example of the reset circuit is shown in Figure 8.12.1. The reset input voltage must be kept 0.9 V or less until the power source voltage surpasses 4.5 V.

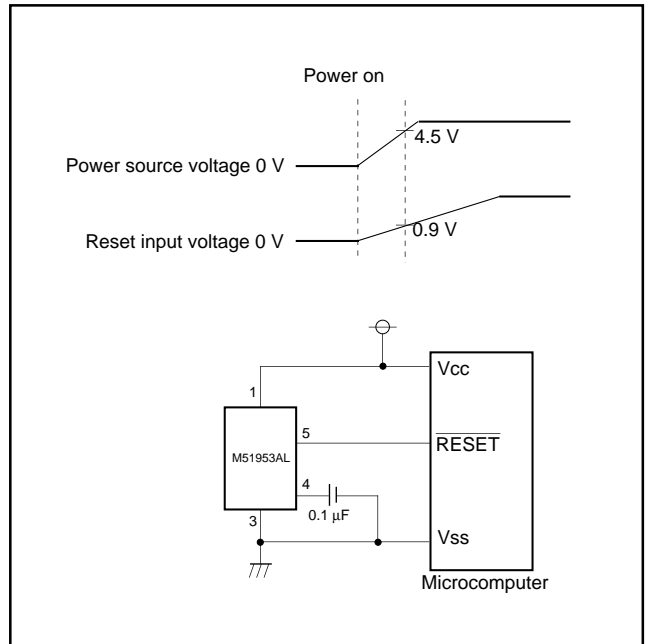

Fig.8.12.1 Example of Reset Circuit

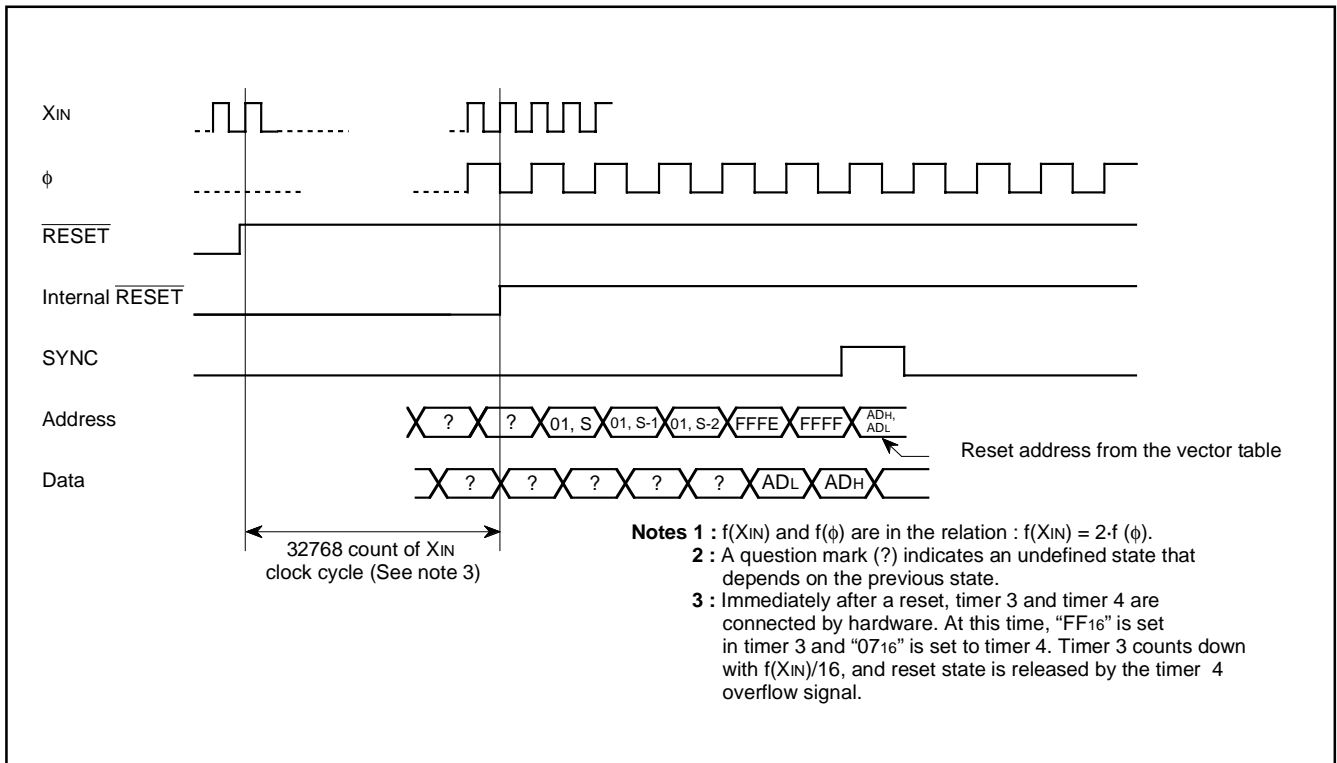

Fig.8.12.2 Reset Sequence

8.13 CLOCK GENERATING CIRCUIT

This microcomputer has 2 built-in oscillation circuits. An oscillation circuit can be formed by connecting a resonator between XIN and XOUT (XCIN and XCOUT). Use the circuit constants in accordance with the resonator manufacturer's recommended values. No external resistor is needed between XIN and XOUT since a feed-back resistor exists on-chip. However, an external feed-back resistor is needed between XCIN and XCOUT. To supply a clock signal externally, input it to the XIN (XCIN) pin and make the XOUT (XCOUT) pin open. When not using XCIN clock, connect the XCIN to VSS and make the XCOUT pin open.

After reset has completed, the internal clock ϕ is half the frequency of XIN. Immediately after power on, both the XIN and XCIN clock start oscillating. To set the internal clock ϕ to low-speed operation mode, set bit 7 of the CPU mode register to "1."

8.13.1 OSCILLATION CONTROL

(1) Stop Mode

The built-in clock generating circuit is shown in Figure 120. When the STP instruction is executed, the internal clock f stops at HIGH. At the same time, timers 3 and 4 are connected by hardware and "FF₁₆" is set in timer 3 and "07₁₆" is set in timer 4. Select $f(XIN)/16$ or $f(XCIN)/16$ as the timer 3 count source (set both bit 0 of timer mode register 2 and bit 6 at address 00C7₁₆ to "0" before the execution of the STP instruction). Moreover, set the timer 3 and timer 4 interrupt enable bits to disabled ("0") before execution of the STP instruction. The oscillator restarts when an external interrupt is accepted. However, the internal clock f keeps its HIGH level until timer 4 overflows, allowing time for oscillation stabilization when a ceramic resonator or a quartz-crystal oscillator is used.

By setting bit 7 of timer return setting register (address 00CC₁₆) to "1," an arbitrary value can be set to timer 3 and timer 4.

Bit 7 of clock control register 3 (address 0202₁₆) can switch Port P10 pin and the CLKCONT. When CLKCONT pin is selected, "H" is output normally. When an external interrupt is received in the STP state, the CLKCONT pin goes back to "H" output.

(2) Wait Mode

When the WIT instruction is executed, the internal clock ϕ stops in the HIGH level but the oscillator continues running. This wait state is released at reset or when an interrupt is accepted (See note). Since the oscillator does not stop, the next instruction can be executed immediately.

Note: In the wait mode, the following interrupts are invalid.

- VSYNC interrupt
- OSD interrupt
- All timer interrupts using external clock input from port pin as count source
- All timer interrupts using $f(XIN)/2$ or $f(XCIN)/2$ as count source
- All timer interrupts using $f(XIN)/4096$ or $f(XCIN)/4096$ as count source
- $f(XIN)/4096$ interrupt
- Multi-master I²C-BUS interface interrupt

(3) Low-speed Mode

If the internal clock is generated from the sub-clock (XCIN), a low power consumption operation can be realized by stopping only the main clock XIN. To stop the main clock, set bit 6 (CM6) of the CPU mode register (00FB₁₆) to "1." When the main clock XIN is restarted, the program must allow enough time for oscillation to stabilize.

Note that in the low-power-consumption mode the XCIN-XCOUT drivability can be reduced, allowing even lower power consumption. To reduce the XCIN-XCOUT drivability, clear bit 5 (CM5) of the CPU mode register (00FB₁₆) to "0." At reset, this bit is set to "1" and strong drivability is selected to help the oscillation to start. When executing an STP instruction, set this bit to "1" by software before initiating the instruction.

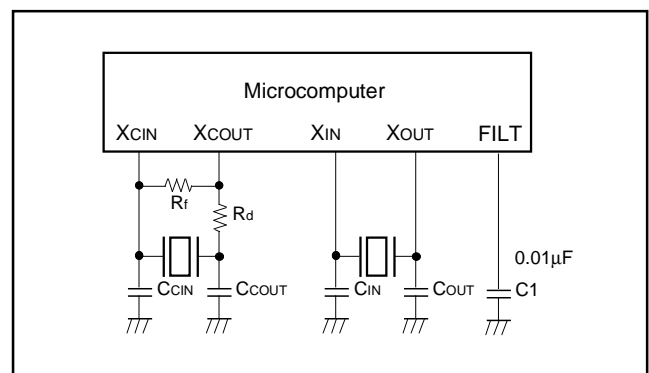

Fig.8.13.1 Ceramic Resonator Circuit Example

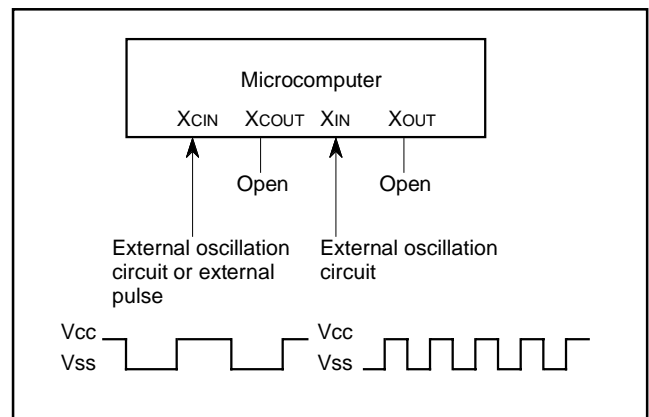

Fig.8.13.2 External Clock Input Circuit Example

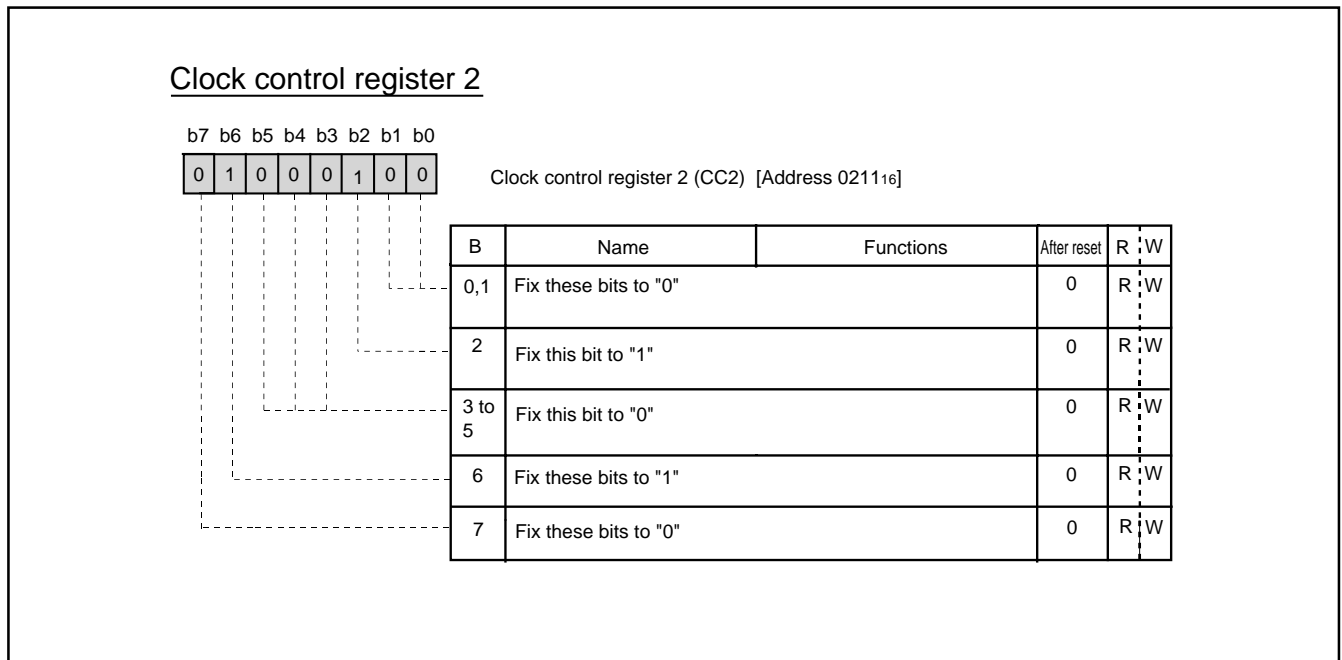

Fig.8.13.3 Clock Control Register 2

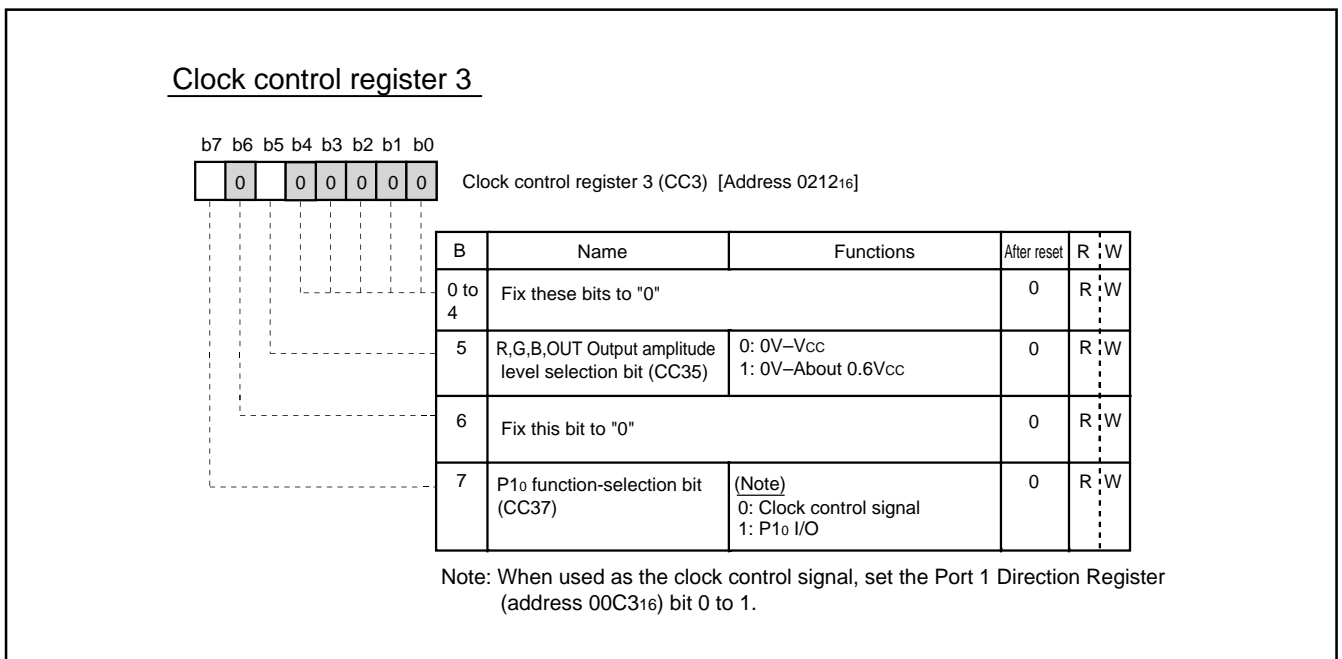

Fig.8.13.4 Clock Control Register 3

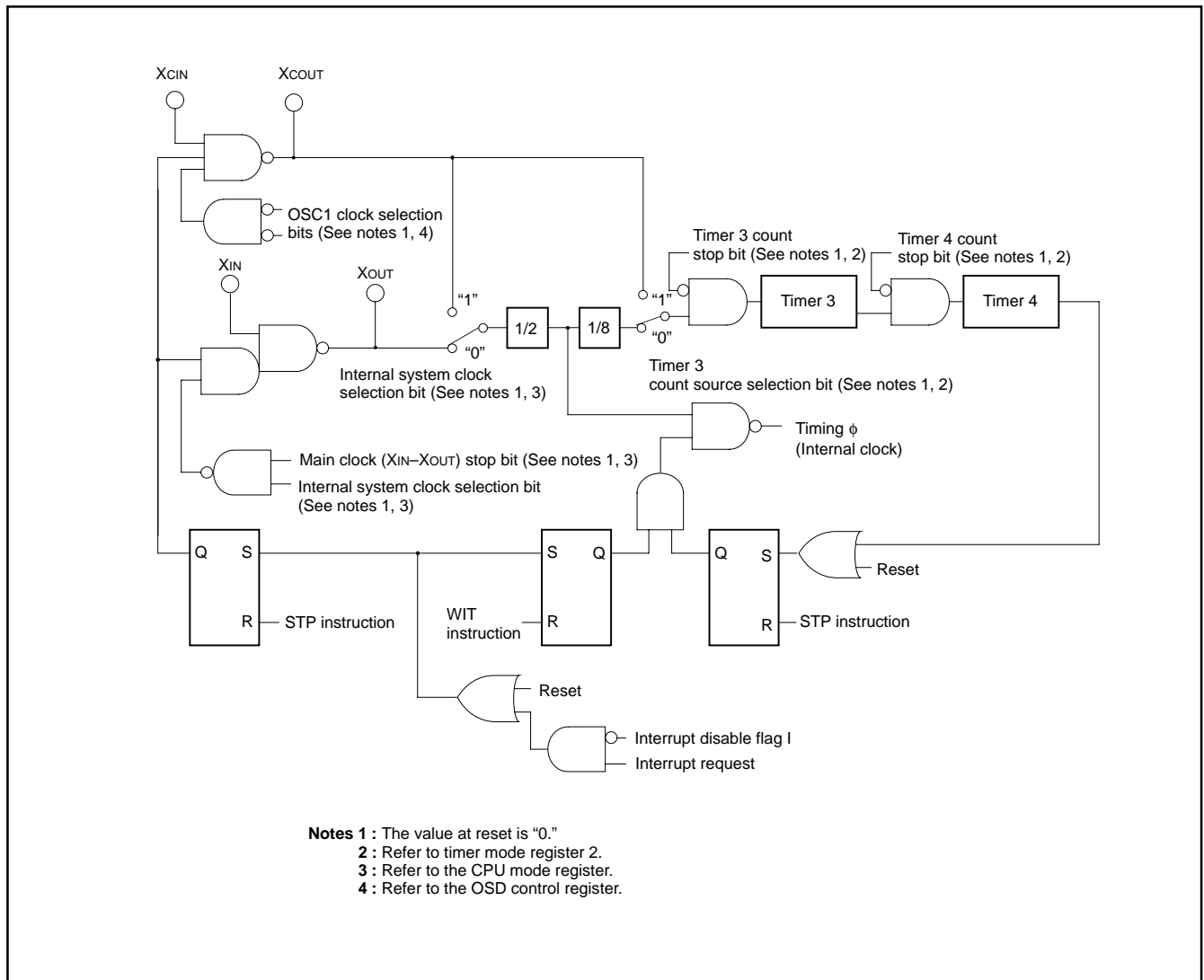

Fig.8.13.5 Clock Generating Circuit Block Diagram

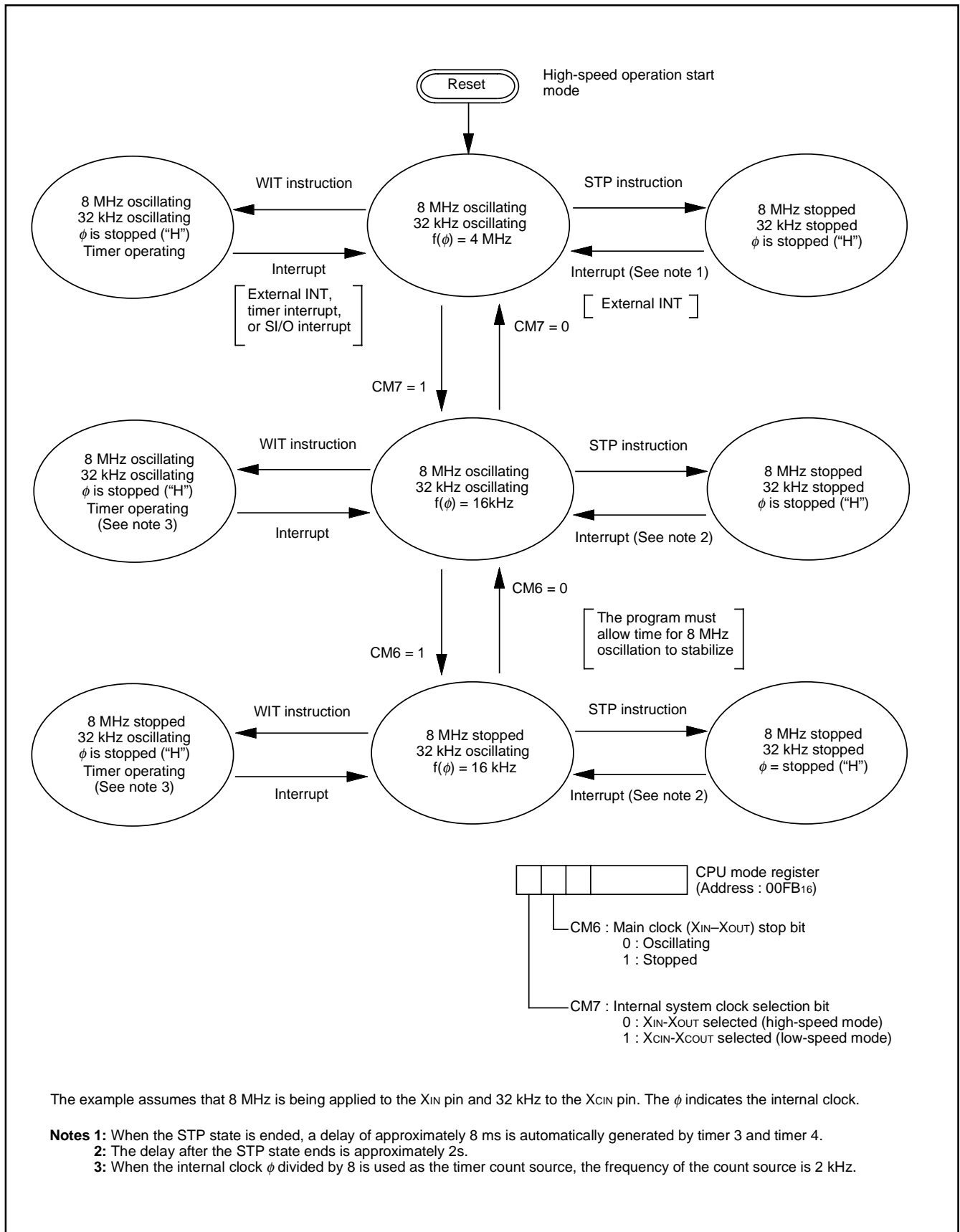

Fig.8.13.6 State Transitions of System Clock

8.14 OSD CLOCK GENERATING CIRCUIT

When generate OSD clock based on main clock, set resistor and capacity to FILT pin as shown in Fig.8.14.1.

Set bit 0 of the clock control register 1 (address 00CD16) to operate OSD clock generating circuit "0." Clock control register 1 (address 00CD16) is shown in Fig.8.14.3. Then, clock frequency for OSD is set up by the clock frequency register (address 021016). Clock frequency setting register is shown in Fig.8.14.2.

In order to generate normally oscillation frequency for OSD shown in Table 8.14.1, be sure to set the main clock f (XIN) to 8MHz. Then, set up not any values other than these.

When not using OSD clock function,the low-power dissipation can relize by setting bit0 of the clock control register to "1."

Table.8.14.1 OSD Clock frequency

Clock frequency setting register (address 021016)	0A	0B	0C	0D
OSD clock frequency	22 MHz	24MHz	26 MHz	28 MHz

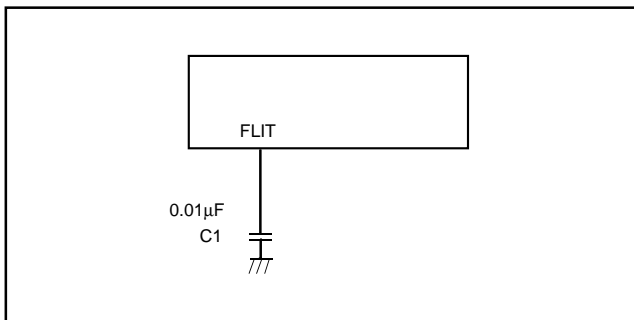

Fig.8.14.1 Display Oscillation Circuit

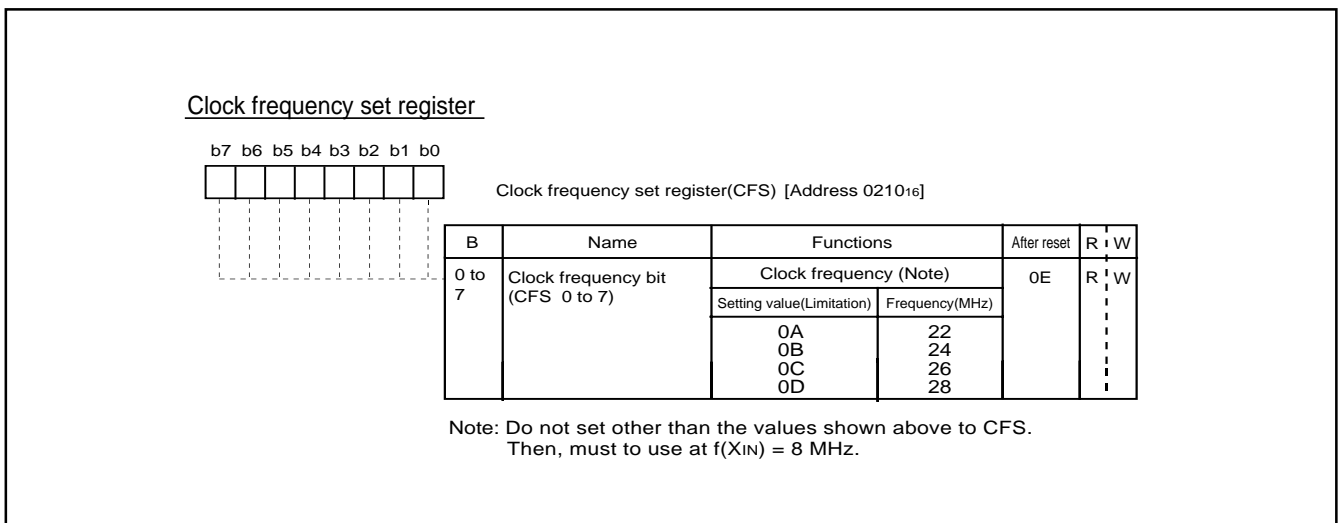

Fig.8.14.2 Clock Frequency Register

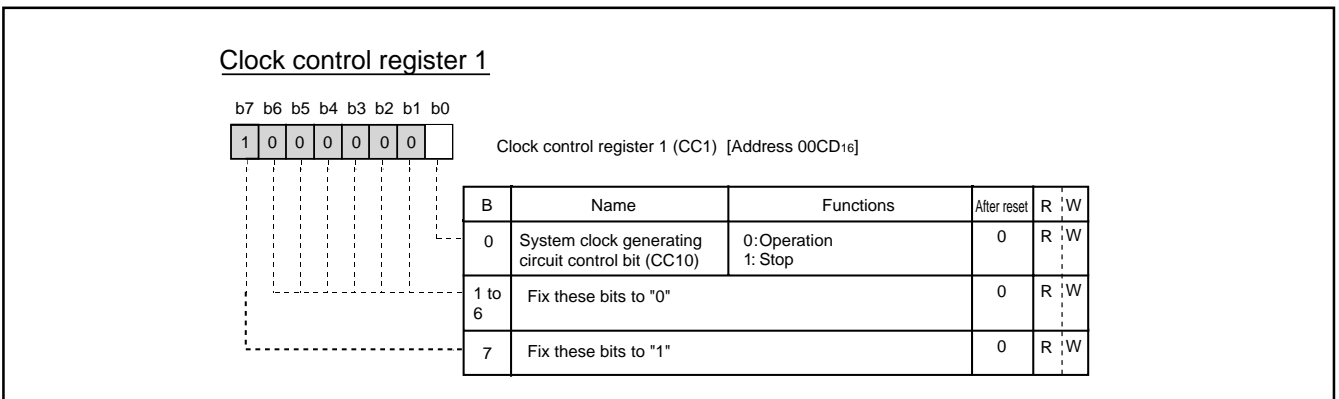

Fig.8.14.3 Clock Control Register 1

8.15 AUTO-CLEAR CIRCUIT

When a power source is supplied, the auto-clear function will operate by connecting the following circuit to the $\overline{\text{RESET}}$ pin.

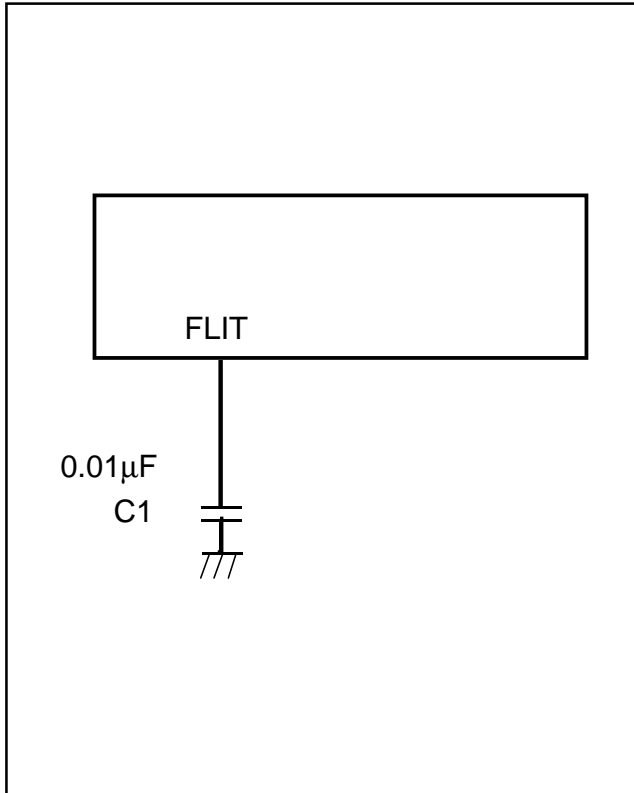

Fig.8.15.1 Auto-clear Circuit Example

8.16 ADDRESSING MODE

The memory access is reinforced with 17 kinds of addressing modes. Refer to SERIES 740 <Software> User's Manual for details.

8.17 MACHINE INSTRUCTIONS

There are 71 machine instructions. Refer to SERIES 740 <Software> User's Manual for details.

9. TECHNICAL NOTES

- The divide ratio of the timer is $1/(n+1)$.
- Even though the BBC and BBS instructions are executed immediately after the interrupt request bits are modified (by the program), those instructions are only valid for the contents before the modification. At least one instruction cycle is needed (such as an NOP) between the modification of the interrupt request bits and the execution of the BBC and BBS instructions.
- After the ADC and SBC instructions are executed (in the decimal mode), one instruction cycle (such as an NOP) is needed before the SEC, CLC, or CLD instruction is executed.
- An NOP instruction is needed immediately after the execution of a PLP instruction.
- In order to avoid noise and latch-up, connect a bypass capacitor ($\approx 0.1\mu\text{F}$) directly between the VCC pin–VSS pin and the VCC pin–CNVSS pin, using a thick wire.
- Characteristic value, margin of operation, etc. of versions with built-in EPROM and built-in mask ROM may differ from each other within the limits of the electrical characteristics in terms of manufacturing process, built-in ROM, difference of a layout pattern, etc.

Carry out and check an examination equivalent to the system evaluation examination carried out on the EPROM version when replacing it with the Mask ROM version.

10. ABSOLUTE MAXIMUM RATINGS

Symbol	Parameter	Conditions	Ratings	Unit
V _{CC}	Power source voltage V _{CC}	All voltages are based on V _{SS} . Output transistors are cut off.	-0.3 to 6	V
V _I	Input voltage C _{NVSS}		-0.3 to 6	V
V _I	Input voltage P00-P07, P10-P16, P20-P27, P30, P31, P35-P37, P50, P51, RESET		-0.3-V _{CC} + 0.3	V
V _O	Output voltage P00-P07, P10-P16, P20-P27, P30, P31, P52-P55		-0.3-V _{CC} + 0.3	V
I _{OH}	Circuit current P10-P16, P20-P27, P30, P31, P52-P55,		0 to 1 (See note 1)	mA
I _{OL1}	Circuit current P00-P07, P10-P15, P16, P20-P23, P52-P55,		0 to 2 (See note 2)	mA
I _{OL2}	Circuit current P11-P14, P30, P31		0 to 6 (See note 2)	mA
I _{OL4}	Circuit current P24-P27		0 to 10 (See note 3)	mA
P _d	Power dissipation	T _a = 25 °C	550	mW
T _{opr}	Operating temperature		-10 to 70	°C
T _{stg}	Storage temperature		-40 to 125	°C

11. RECOMMENDED OPERATING CONDITIONS (T_a = -10 °C to 70 °C, V_{CC} = 5 V ± 10 %, unless otherwise noted)

Symbol	Parameter	Limits			Unit
		Min.	Typ.	Max.	
V _{CC}	Power source voltage (See note 4)	4.5	5.0	5.5	V
V _{SS}	Power source voltage	0	0	0	V
V _{IH1}	HIGH Input voltage P00-P07, P10-P16, P20-P27, P30, P31, P35-P37, P50, P51, RESET	0.8V _{CC}		V _{CC}	V
V _{IH2}	HIGH Input voltage SCL1, SCL2, SCL3, SDA1, SDA2, SDA3 (When using I ² C-BUS)	0.7V _{CC}		V _{CC}	V
V _{IL1}	LOW Input voltage P00-P07, P10-P16, P20-P27, P30, P31, P35-P37	0		0.4V _{CC}	V
V _{IL2}	LOW Input voltage SCL1, SCL2, SCL3, SDA1, SDA2, SDA3 (When using I ² C-BUS)	0		0.3V _{CC}	V
V _{IL3}	LOW Input voltage (See note 6) P50, P51, RESET, TIM2, TIM3, INT1, INT2, INT3, SIN, SCLK	0		0.2V _{CC}	V
I _{OH}	HIGH average output current (See note 1) P10-P16, P20-P27, P30, P31, P52-P55			1	mA
I _{OL1}	HIGH average output current (See note 2) P00-P07, P10, P15, P16, P20-P23, P52-P55			2	mA
I _{OL2}	LOW average output current (See note 2) P11-P14, P30, P31			6	mA
I _{OL3}	LOW average output current (See note 3) P24-P27			10	mA
f(XIN)	Oscillation frequency (for CPU operation)(See note 5) XIN	7.9	8.0	8.1	MHz
f(XCIN)	Oscillation frequency (for sub-clock operation) XCIN	29	32	35	kHz
f _{hs1}	Input frequency TIM2, TIM3, INT1, INT2, INT3			100	kHz
f _{hs2}	Input frequency SCLK			1	MHz
f _{hs3}	Input frequency SCL1, SCL2			400	kHz
f _{hs4}	Input frequency Horizontal sync. signal of video signal	15.262	15.734	16.206	kHz

12. ELECTRIC CHARACTERISTICS ($V_{CC} = 5\text{ V} \pm 10\%$, $V_{SS} = 0\text{ V}$, $f(X_{IN}) = 8\text{ MHz}$, $T_a = -10\text{ }^\circ\text{C}$ to $70\text{ }^\circ\text{C}$, unless otherwise noted)

Symbol	Parameter		Test conditions		Limits			Unit	Test circuit
					Min.	Typ.	Max.		
I _{CC}	Power source current	System operation	V _{CC} = 5.5V, f(X _{IN}) = 8MHz	OSD OFF		15	30	mA	1
				OSD ON		30	45		
			V _{CC} = 5.5V, f(X _{IN}) = 0, f(X _{CIN}) = 32kHz, OSD OFF Low-power dissipation mode set (CM5 = "0", CM6 = "1")			60	200	μA	
		Wait mode	V _{CC} = 5.5 V, f(X _{IN}) = 8 MHz			1	2	mA	
			V _{CC} = 5.5 V, f(X _{IN}) = 0, f(X _{CIN}) = 32 kHz, Low-power dissipation mode set (CM5 = "0", CM6 = "1")			25	100	μA	
		Stop mode	V _{CC} = 5.5V, f(X _{IN}) = 0, f(X _{CIN}) = 0			1	10		
VOH	HIGH output voltage	P10–P16, P20–P27, P30, P31, P52–P55,	V _{CC} = 4.5 V I _{OH} = –0.5 mA		2.4			V	2
VOL	LOW output voltage	P00–P07, P10, P15, P16, P20–P23, P52–P55	V _{CC} = 4.5 V I _{OL} = 0.5 mA				0.4	V	
	LOW output voltage	P24– P27	V _{CC} = 4.5 V I _{OL} = 10.0 mA				3.0		
	LOW output voltage	P11–P14, P30, P32	V _{CC} = 4.5 V	I _{OL} = 3 mA			0.4		
				I _{OL} = 6 mA			0.6		
V _{T+} –V _{T–}	Hysteresis (See note 6) RESET, P50, P51, INT1, INT2, INT3, TIM2, TIM3, S _{IN} , S _{CLK} , S _{CL} 1, S _{CL} 2, S _{CL} 3, S _{DA} 1, S _{DA} 2, S _{DA} 3		V _{CC} = 5.0 V			0.5	1.3	V	3
I _{IzH}	HIGH input leak current P00–P07, P10–P16, P20–P27, P30, P31, P35–P37, RESET, P50, P51,		V _{CC} = 5.5 V V _I = 5.5 V				5	μA	4
I _{IzL}	LOW input leak current P00–P07, P10–P16, P20–P27, P30, P31, P35–P37, P50, P51, RESET		V _{CC} = 5.5 V V _I = 0 V				5	μA	4
R _{BS}	I ² C-BUS • BUS switch connection resistor (between S _{CL} 1 and S _{CL} 2, S _{DA} 1 and S _{DA} 2)		V _{CC} = 4.5 V				130	Ω	5

Notes 1: The total current that flows out of the IC must be 20 mA or less.

2: The total input current to IC (I_{OL1} + I_{OL2}) must be 30 mA or less.

3: The total average input current for ports P24–P27 and AV_{CC}–V_{SS} to IC must be 20 mA or less.

4: Connect 0.1 μF or more capacitor externally between the power source pins V_{CC}–V_{SS} so as to reduce power source noise.

Also connect 0.1 μF or more capacitor externally between the pins V_{CC}–CNV_{SS}.

5: Use a quartz-crystal oscillator or a ceramic resonator for the CPU oscillation circuit(X_{IN},X_{OUT}).

6: P06, P07, P16, P23, P24, P25 have hysteresis when used as interrupt input pins or timer input pins. P11–P14, P30, P31 have hysteresis when used as multi-master I²C-BUS interface ports. P20–P22 have hysteresis when used as serial I/O pins.

7: Pin names in each parameter are described as below.

(1) Dedicated pins: dedicated pin names.

(2) Double-/triple-function ports

• Same limits: I/O port name.

• Functions other than ports vary from I/O port limits : function pin name.

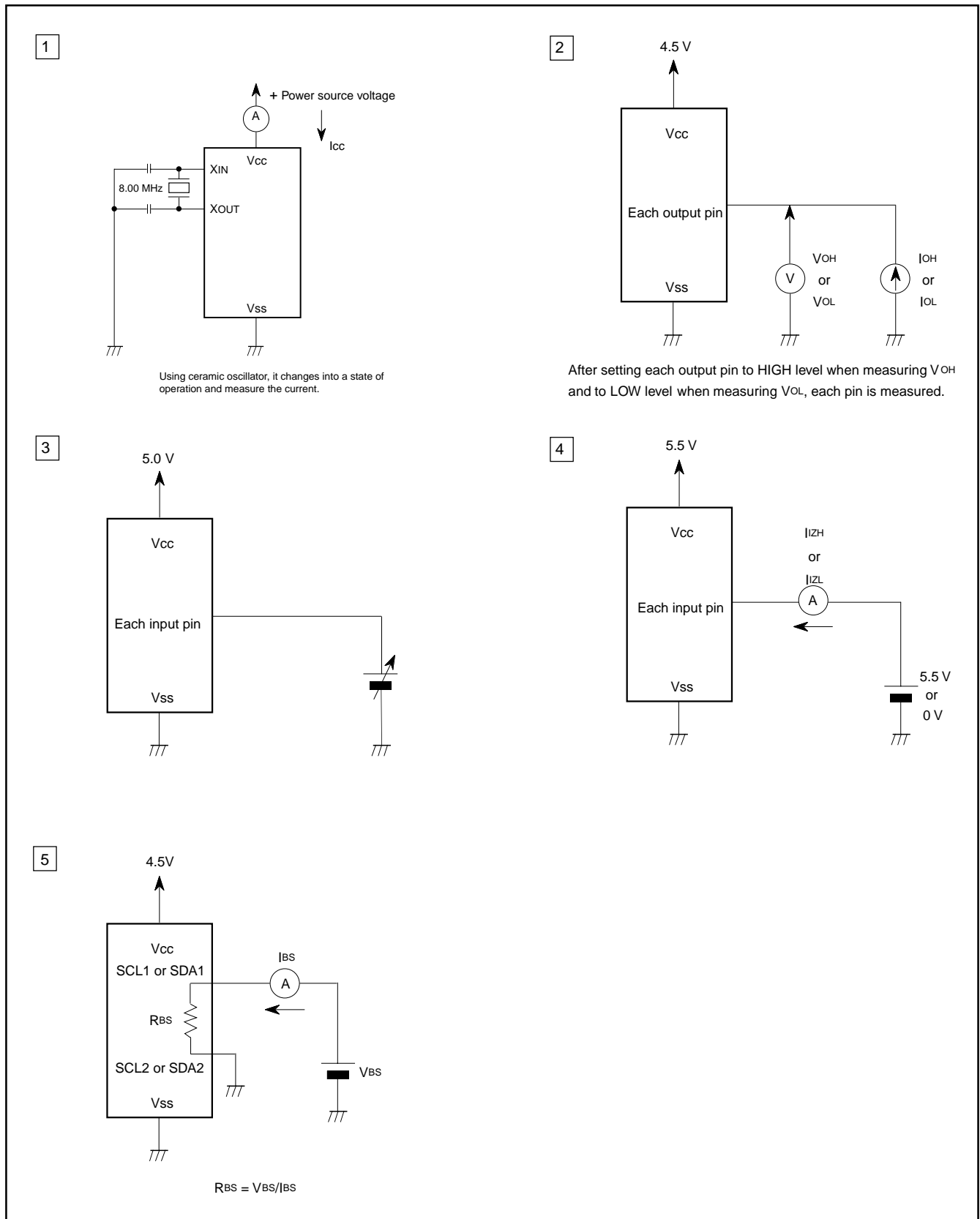

Fig.12.1 Measurement Circuits

13. A-D CONVERTER CHARACTERISTICS

(VCC = 5 V ± 10 %, VSS = 0 V, f(XIN) = 8MHz, Ta = -10 °C to 70 °C, unless otherwise noted)

Symbol	Parameter	Test conditions	Limits			Unit
			Min.	Typ.	Max.	
—	Resolution				7	bits
—	Non-linearity error				±1.5	LSB
—	Differential non-linearity error				±0.9	LSB
V0T	Zero transition error	IOL (SUM) = 0 mA			2	LSB
VFST	Full-scale transition error				-2	LSB

14. MULTI-MASTER I²C-BUS BUS LINE CHARACTERISTICS

Symbol	Parameter	Standard clock mode		High-speed clock mode		Unit
		Min.	Max.	Min.	Max.	
tBUF	Bus free time	4.7		1.3		μs
tHD; STA	Hold time for START condition	4.0		0.6		μs
tLOW	LOW period of SCL clock	4.7		1.3		μs
tR	Rising time of both SCL and SDA signals		1000	20+0.1Cb	300	ns
tHD; DAT	Data hold time	0		0	0.9	μs
tHIGH	HIGH period of SCL clock	4.0		0.6		μs
tF	Falling time of both SCL and SDA signals		300	20+0.1Cb	300	ns
tSU; DAT	Data set-up time	250		100		ns
tSU; STA	Set-up time for repeated START condition	4.7		0.6		μs
tSU; STO	Set-up time for STOP condition	4.0		0.6		μs

Note: Cb = total capacitance of 1 bus line

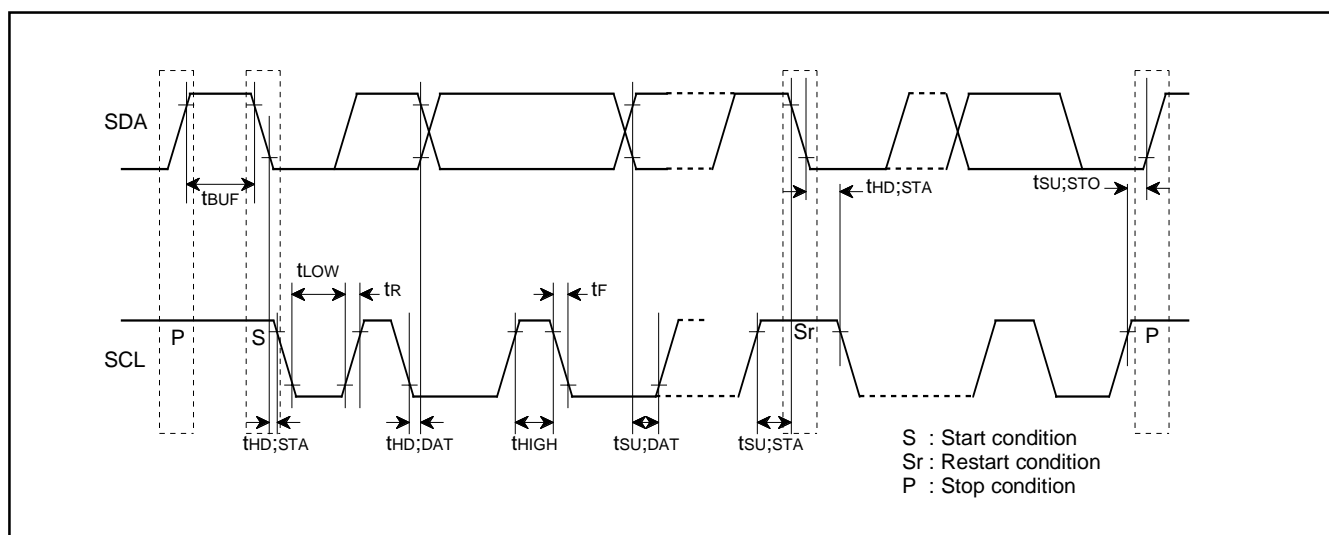

Fig.14.1 Definition Diagram of Timing on Multi-master I²C-BUS

15. PROM PROGRAMMING METHOD

The built-in PROM of the One Time PROM version (blank) and the built-in EPROM version can be read or programmed with a general-purpose PROM programmer using a special programming adapter.

Product	Name of Programming Adapter
M37161EFSP	PCA7450SP
M37161EFPF	PCA7450FP

The PROM of the One Time PROM version (blank) is not tested or screened in the assembly process nor any following processes. To ensure proper operation after programming, the procedure shown in Figure 15.1 is recommended to verify programming.

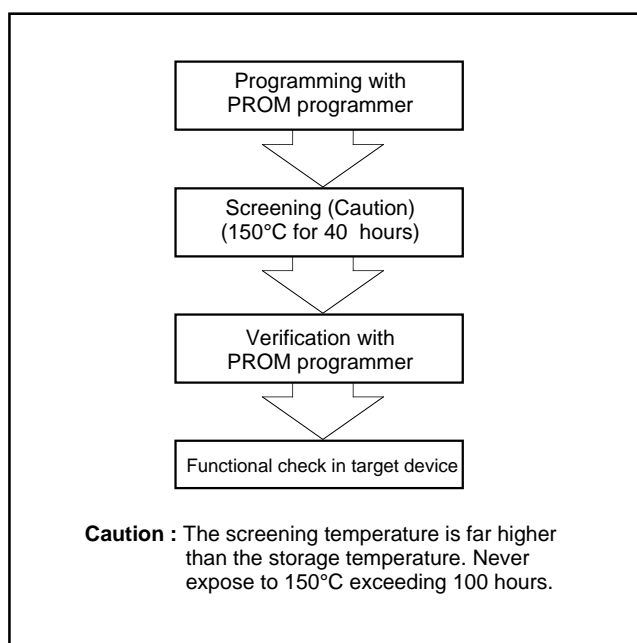

Fig. 15.1 Programming and Testing of One Time PROM Version

16. DATA REQUIRED FOR MASK ORDERS

The following are necessary when ordering a mask ROM production:

- Mask ROM Order Confirmation Form
- Mask Specification Form
- Data to be written to ROM, in EPROM form (three identical copies) or FDK

When using EPROM:

Three sets of 32-pin DIP Type 27C101

17. ONE TIME PROM VERSION M37161EFSP/FP MARKING

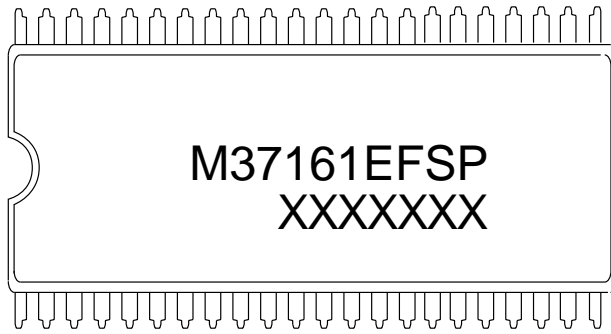

XXXXXXX is lot number



XXXXXXX is lot number

18. APPENDIX

Pin Configuration (TOP VIEW)

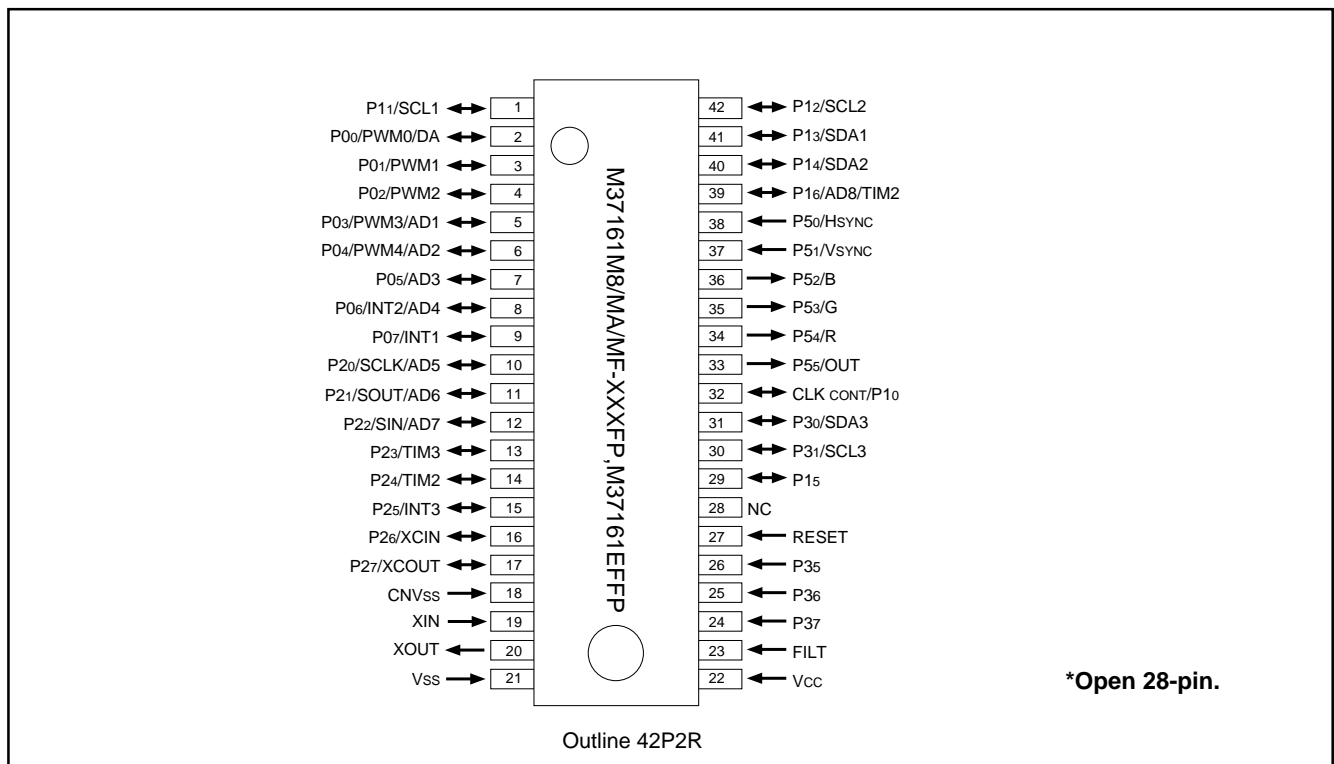
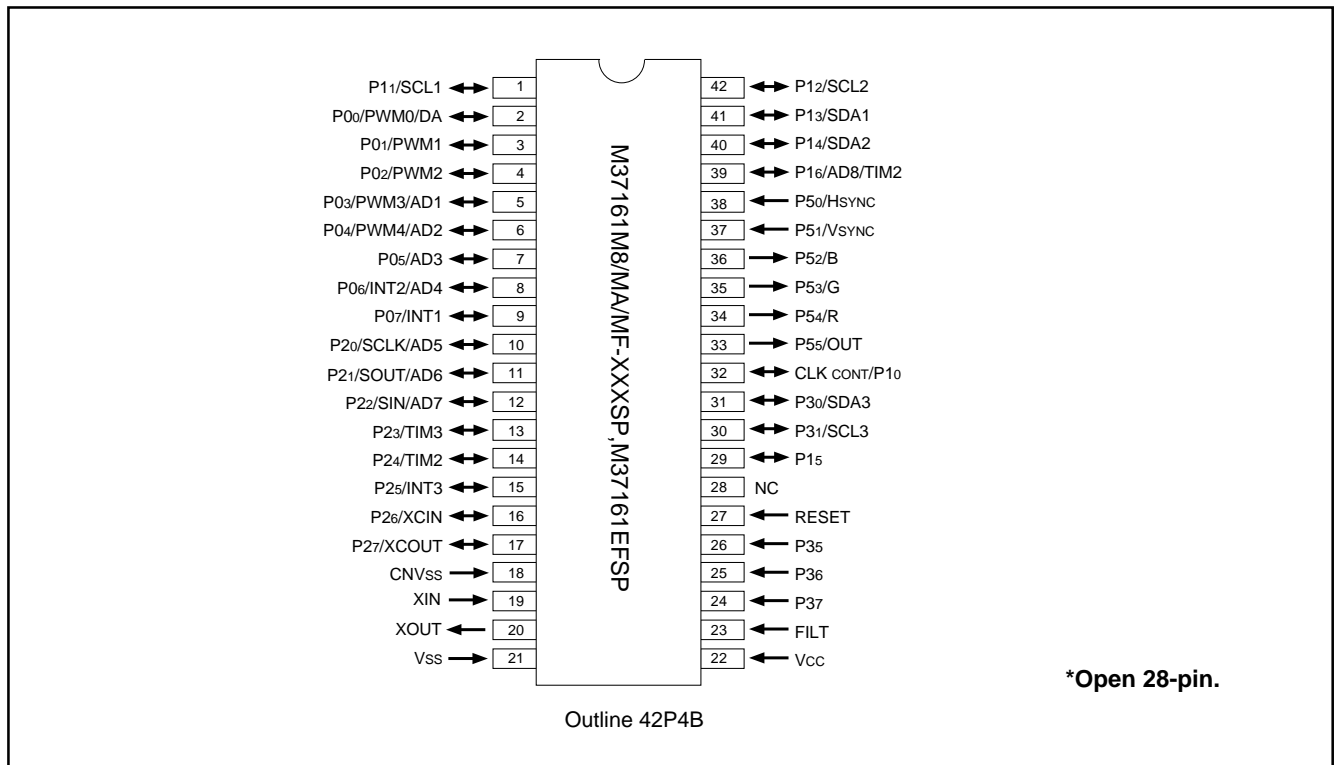

Memory Map

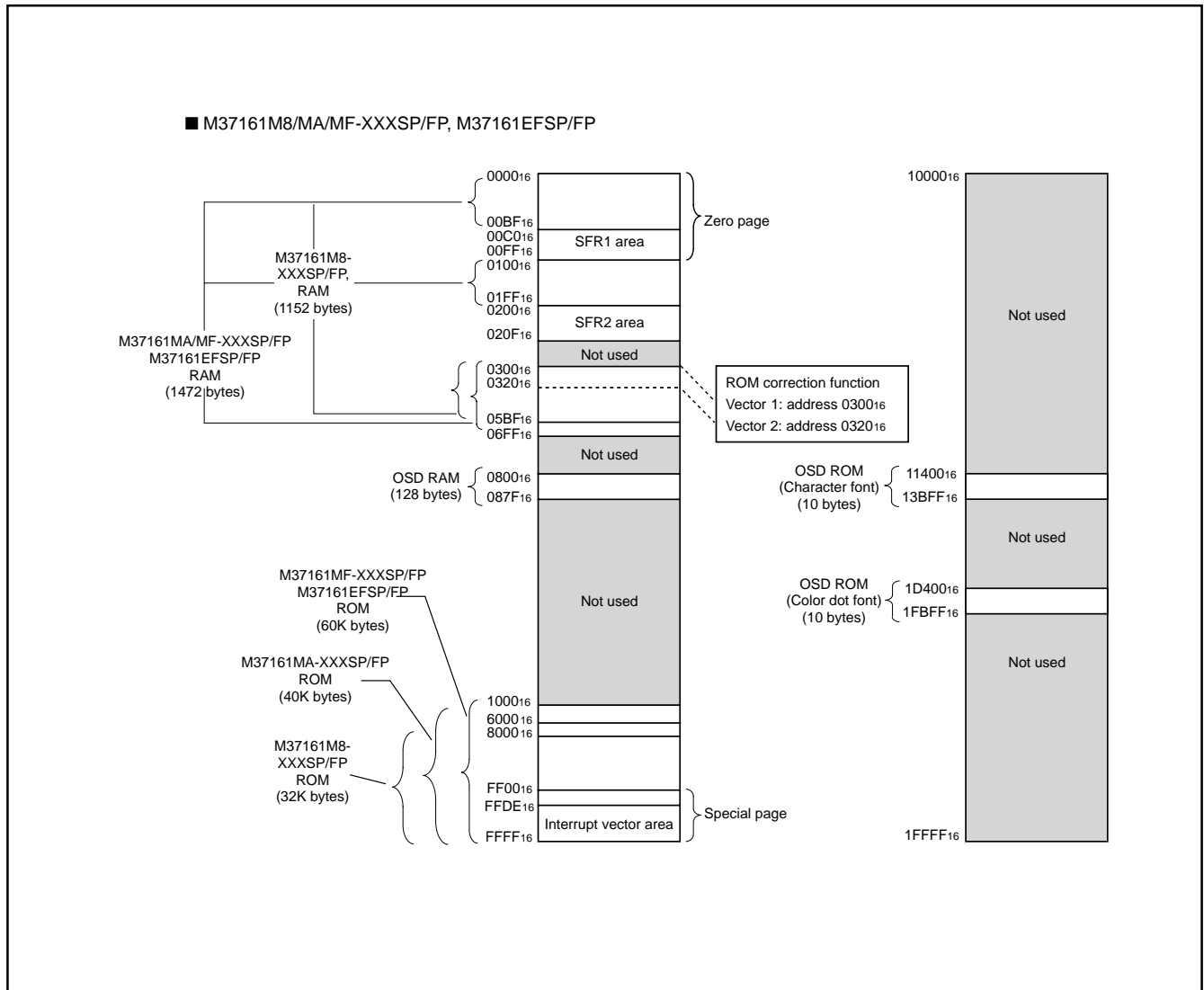

Memory Map of Special Function Register (SFR)

■ SFR1 Area (addresses C0₁₆ to DF₁₆)

<Bit allocation>

- : } Function bit
- : No function bit
- : Fix this bit to "0"
(do not write "1")
- : Fix this bit to "1"
(do not write "0")

<State immediately after reset>

- : "0" immediately after reset
- : "1" immediately after reset
- : Indeterminate immediately after reset

Address	Register	Bit allocation								State immediately after reset								
		b7						b0		b7						b0		
C0 ₁₆	Port P0(P0)									?								
C1 ₁₆	Port P0 direction register (D0)									00 ₁₆								
C2 ₁₆	Port P1(P1)	<input checked="" type="checkbox"/>								? ? 0 ? ? ? ? ?								
C3 ₁₆	Port P1 direction register (D1)	<input checked="" type="checkbox"/>								0 0 1 0 0 0 0 1								
C4 ₁₆	Port P2(P2)									?								
C5 ₁₆	Port P2 direction register (D2)									00 ₁₆								
C6 ₁₆	Port P3(P3)	P37	P36	P35		BSEL21	BSEL20	P31	P30	? ? ? 0 0 0 ? ?								
C7 ₁₆	Port P3 direction register (D3)	T2SC	T3SC	1		0	OUTS	P31D	P30D	00 ₁₆								
C8 ₁₆		<input checked="" type="checkbox"/>	<input checked="" type="checkbox"/>	<input checked="" type="checkbox"/>	<input checked="" type="checkbox"/>	<input checked="" type="checkbox"/>	<input checked="" type="checkbox"/>	<input checked="" type="checkbox"/>	<input checked="" type="checkbox"/>	?								
C9 ₁₆		<input checked="" type="checkbox"/>	<input checked="" type="checkbox"/>	1	1	1	1	1	1	?								
CA ₁₆	Port P5(P5)	<input checked="" type="checkbox"/>	<input checked="" type="checkbox"/>					<input checked="" type="checkbox"/>	<input checked="" type="checkbox"/>	?								
CB ₁₆	OSD port control register (PF)	<input checked="" type="checkbox"/>	<input checked="" type="checkbox"/>	PF5	PF4	PF3	PF2	<input checked="" type="checkbox"/>	<input checked="" type="checkbox"/>	0 ? 0 0 0 0 0 0								
CC ₁₆	Timer return set register (TMS)	TMS	1	1	0	0	0	0	0	00 ₁₆								
CD ₁₆	Clock control register 1 (CC1)	1	0	0	0	0	0	0	CC10	00 ₁₆								
CE ₁₆										?								
CF ₁₆										?								
D0 ₁₆	OSD control register (OC)	OC7	<input checked="" type="checkbox"/>	<input checked="" type="checkbox"/>	1	1	OC2	OC1	OC0	00 ₁₆								
D1 ₁₆	Horizontal position register (HP)		HP6	HP5	HP4	HP3	HP2	HP1	HP0	00 ₁₆								
D2 ₁₆	Block control register 1(BC1)	BC17	BC16	BC15	BC14	BC13	BC12	BC11	BC10	?								
D3 ₁₆	Block control register 2(BC2)	BC27	BC26	BC25	BC24	BC23	BC22	BC21	BC20	?								
D4 ₁₆	Vertical position register 1(VP1)	VP17	VP16	VP15	VP14	VP13	VP12	VP11	VP10	?								
D5 ₁₆	Vertical position register 2(VP2)	VP27	VP26	VP25	VP24	VP23	VP22	VP21	VP20	?								
D6 ₁₆	Window register 1(WN1)	WN17	WN16	WN15	WN14	WN13	WN12	WN11	WN10	?								
D7 ₁₆	Window register 2(WN2)	WN27	WN26	WN25	WN24	WN23	WN22	WN21	WN20	?								
D8 ₁₆	I/O polarity control register (PC)	<input checked="" type="checkbox"/>	PC6	PC5	<input checked="" type="checkbox"/>	PC3	PC2	PC1	PC0	40 ₁₆								
D9 ₁₆	Raster color register (RC)	RC7	<input checked="" type="checkbox"/>	<input checked="" type="checkbox"/>	<input checked="" type="checkbox"/>	RC3	RC2	RC1	RC0	00 ₁₆								
DA ₁₆	Color dot OSD control register (CDT)							CDT1	CDT0	?								
DB ₁₆	OSD control register 2(OC2)	<input checked="" type="checkbox"/>	<input checked="" type="checkbox"/>	<input checked="" type="checkbox"/>			<input checked="" type="checkbox"/>	OC21	OC20	0 0 0 ? 0 0 0 0								
DC ₁₆	Interrupt input polarity control register (RE)						INT3	INT2	INT1	00 ₁₆								
DD ₁₆										00 ₁₆								
DE ₁₆										00 ₁₆								
DF ₁₆										00 ₁₆								

■ SFR1 Area (addresses E0₁₆ to FF₁₆)

<Bit allocation>

- : } Function bit
- Name : }
- : No function bit
- 0 : Fix this bit to "0"
(do not write "1")
- 1 : Fix this bit to "1"
(do not write "0")

<State immediately after reset>

- 0 : "0" immediately after reset
- 1 : "1" immediately after reset
- ? : Indeterminate immediately after reset

Address	Register	Bit allocation								State immediately after reset							
		b7							b0	b7							b0
E0 ₁₆																	?
E1 ₁₆																	?
E2 ₁₆																	?
E3 ₁₆																	?
E4 ₁₆																	?
E5 ₁₆																	?
E6 ₁₆																	?
E7 ₁₆																	?
E8 ₁₆																	?
E9 ₁₆																	?
EA ₁₆	Serial I/O register (SIO)																?
EB ₁₆	Serial I/O mode register (SM)	0	SM6	SM5	0	SM3	SM2	SM1	SM0								00 ₁₆
EC ₁₆	A-D control register 1 (AD1)					ADC14		ADC12	ADC11	ADC10							0 0 0 0 ? 0 0 0 0
ED ₁₆	A-D control register 2 (AD2)					ADC26	ADC25	ADC24	ADC23	ADC22	ADC21	ADC20					00 ₁₆
EE ₁₆	Timer 5 (T5)																07 ₁₆
EF ₁₆	Timer 6 (T6)																FF ₁₆
F0 ₁₆	Timer 1 (T1)																FF ₁₆
F1 ₁₆	Timer 2 (T2)																07 ₁₆
F2 ₁₆	Timer 3 (T3)																FF ₁₆
F3 ₁₆	Timer 4 (T4)																07 ₁₆
F4 ₁₆	Timer mode register 1 (TM1)	TM17	TM16	TM15	TM14	TM13	TM12	TM11	TM10								00 ₁₆
F5 ₁₆	Timer mode register 2 (TM2)	TM27	TM26	TM25	TM24	TM23	TM22	TM21	TM20								00 ₁₆
F6 ₁₆	I ² C data shift register (S0)	D7	D6	D5	D4	D3	D2	D1	D0								?
F7 ₁₆	I ² C address register (S0D)	SAD6	SAD5	SAD4	SAD3	SAD2	SAD1	SAD0	RBW								00 ₁₆
F8 ₁₆	I ² C status register (S1)	MST	TRX	BB	PIN	AL	AAS	AD0	LRB								0 0 0 0 1 0 0 0 ?
F9 ₁₆	I ² C control register (S1D)	BSEL1	BSEL0	¹⁰ BIT SAD	ALS	ESO	BC2	BC1	BC0								00 ₁₆
FA ₁₆	I ² C clock control register (S2)	ACK BIT	FAST MODE	CCR4	CCR3	CCR2	CCR1	CCR0									00 ₁₆
FB ₁₆	CPU mode register (CPUM)	CM7	CM6	CM5	1	1	CM2	0	0								3C ₁₆
FC ₁₆	Interrupt request register 1 (IREQ1)		IN3R	VSCR	OSDR	TM4R	TM3R	TM2R	TM1R								00 ₁₆
FD ₁₆	Interrupt request register 2 (IREQ2)	0	TM56R	IICR	IN2R	CKR	S1R	0	IN1R								00 ₁₆
FE ₁₆	Interrupt control register 1 (ICON1)		IN3E	VSCE	OSDE	TM4E	TM3E	TM2E	TM1E								00 ₁₆
FF ₁₆	Interrupt control register 2 (ICON2)	TM56C	TM56E	IICE	IN2E	CKE	S1E	0	IN1E								00 ₁₆

■SFR2 Area (addresses 200₁₆ to 20F₁₆)

<Bit allocation>

: } Function bit
 Name : }

: No function bit

0 : Fix this bit to "0"
 (do not write "1")

1 : Fix this bit to "1"
 (do not write "0")

<State immediately after reset>

0 : "0" immediately after reset

1 : "1" immediately after reset

? : Indeterminate immediately after reset

Address	Register	Bit allocation								State immediately after reset							
		b7							b0	b7							b0
200 ₁₆	PWM0 register (PWM0)																?
201 ₁₆	PWM1 register (PWM1)																?
202 ₁₆	PWM2 register (PWM2)																?
203 ₁₆	PWM3 register (PWM3)																?
204 ₁₆	PWM4 register (PWM4)																?
205 ₁₆		00 ₁₆															?
206 ₁₆	DA-H register (DAH)																?
207 ₁₆	DA-L register (DAL)									0	0	?	?	?	?	?	?
208 ₁₆	PWM mode register 1 (PM1)					PM14	PM13		PM10	?	?	?	0	0	?	?	0
209 ₁₆	PWM mode register 2 (PM2)	0	0	PM25	PM24	PM23	PM22	PM21	PM20	00 ₁₆							
20A ₁₆	ROM correction address 1 (high-order)									00 ₁₆							
20B ₁₆	ROM correction address 1 (low-order)									00 ₁₆							
20C ₁₆	ROM correction address 2 (high-order)									00 ₁₆							
20D ₁₆	ROM correction address 2 (low-order)									00 ₁₆							
20E ₁₆	ROM correction enable register (RCR)							RC1	RC0	00 ₁₆							
20F ₁₆										?							
210 ₁₆	Clock frequency set register (CFS)									0	0	0	0	1	1	1	0
211 ₁₆	Clock control register 2(CC2)	0	1	0	0	0	1	0	0	00 ₁₆							
212 ₁₆	Clock control register 3(CC3)	CC37	0	CC35	0	0	0	0	0	00 ₁₆							
213 ₁₆	Test register	0	0	0	0	0	0	0	0	00 ₁₆							

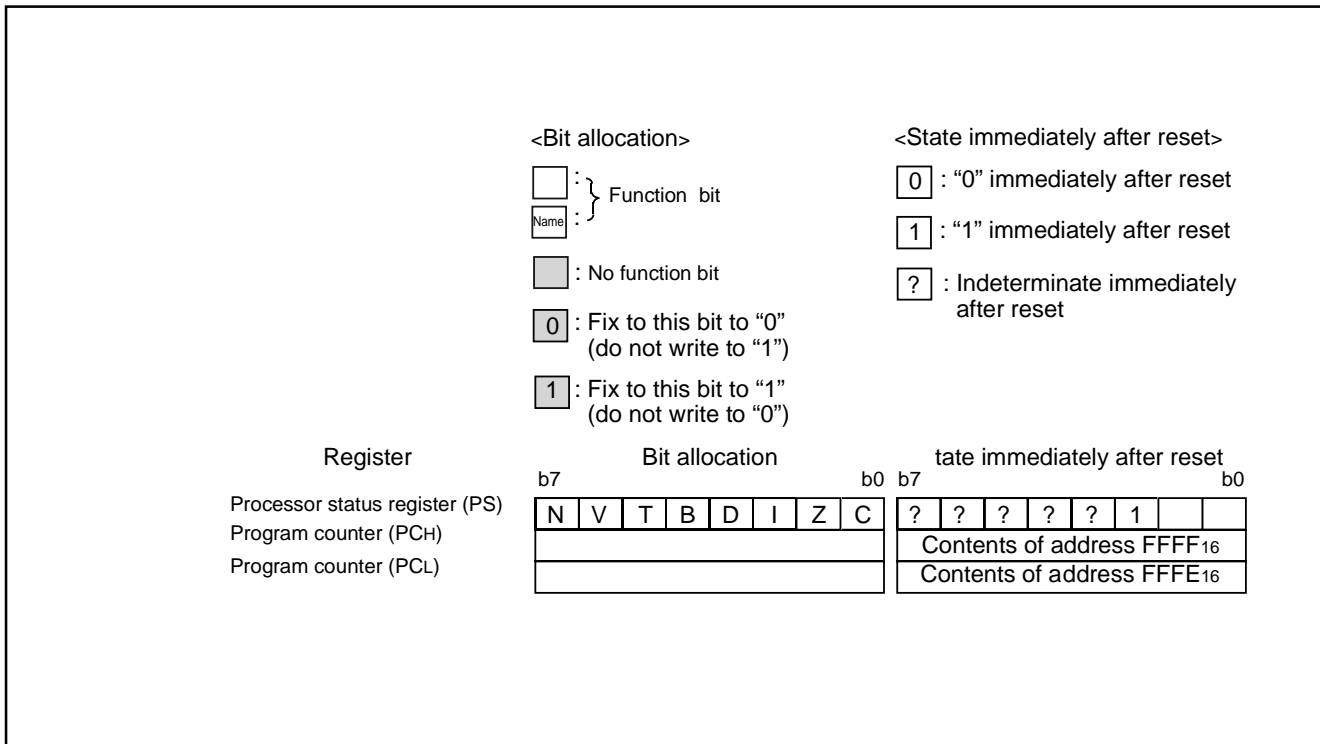

Structure of Register

The figure of each register structure describes its functions, contents at reset, and attributes as follows:

<Example>

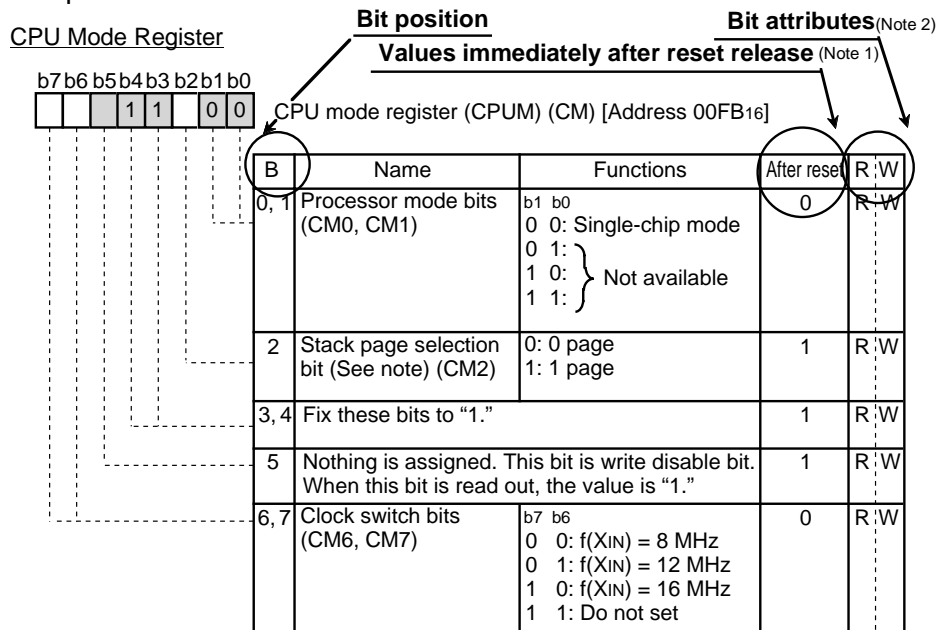

■ : Bit in which nothing is assigned

Notes 1: Values immediately after reset release

- 0 "0" after reset release
- 1 "1" after reset release
- Indeterminate...Indeterminate after reset

release

2: Bit attributes.....The attributes of control register bits are classified into 3 types : read-only, write-only and read and write. In the figure, these attributes are represented as follows :

R.....Read

- RRead enabled
-Read disabled

W.....Write

- WWrite enabled
-Write disabled
- * "0" can be set by software, but "1" cannot be set.

17. Appendix

Address 00C1₁₆, 00C5₁₆

Port Pi Direction Register

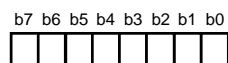

Port Pi direction register (Di) (i=0, 2) [Addresses 00C1₁₆, 00C5₁₆]

B	Name	Functions	After reset	R	W
0	Port Pi direction register	0 : Port P _{i0} input mode 1 : Port P _{i0} output mode	0	R	W
1		0 : Port P _{i1} input mode 1 : Port P _{i1} output mode	0	R	W
2		0 : Port P _{i2} input mode 1 : Port P _{i2} output mode	0	R	W
3		0 : Port P _{i3} input mode 1 : Port P _{i3} output mode	0	R	W
4		0 : Port P _{i4} input mode 1 : Port P _{i4} output mode	0	R	W
5		0 : Port P _{i5} input mode 1 : Port P _{i5} output mode	0	R	W
6		0 : Port P _{i6} input mode 1 : Port P _{i6} output mode	0	R	W
7		0 : Port P _{i7} input mode 1 : Port P _{i7} output mode	0	R	W

Address 00C2₁₆

Port P1 register

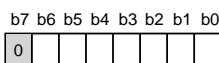

Port P1 register (P1) [Address 00C2₁₆]

B	Name	Functions	After reset	R	W
0	Port P1 register	Port P ₁₀ data	Indeterminate	R	W
1		Port P ₁₁ data	Indeterminate	R	W
2		Port P ₁₂ data	Indeterminate	R	W
3		Port P ₁₃ data	Indeterminate	R	W
4		Port P ₁₄ data	Indeterminate	R	W
5		Port P ₁₅ data	0	R	W
6	Port P ₁₆ data	Indeterminate	Indeterminate	R	W
7	Fix this bit to "0"		Indeterminate	R	W

Address 00C316

Port P1 direction register

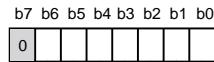

Port P1 direction register (D1) [Address 00C316]

B	Name	Functions	After reset	R	W
0	Port P1 direction register	0 : Port P1 ₀ input mode (note) 1 : Port P1 ₀ output mode	1	R	W
1		0 : Port P1 ₁ input mode 1 : Port P1 ₁ output mode	0	R	W
2		0 : Port P1 ₂ input mode 1 : Port P1 ₂ output mode	0	R	W
3		0 : Port P1 ₃ input mode 1 : Port P1 ₃ output mode	0	R	W
4		0 : Port P1 ₄ input mode 1 : Port P1 ₄ output mode	0	R	W
5		0 : Port P1 ₅ input mode 1 : Port P1 ₅ output mode	1	R	W
6		0 : Port P1 ₆ input mode 1 : Port P1 ₆ output mode	0	R	W
7	Fix this bit to "0"		0	R	W

Note: When using P10 as a general-purpose port, set the Clock Control Register 3 (address 021216) bit 7 to 1.
When using P10 as a clock control signal, refer to 8.14.1 oscillation control. P10 becomes clock control signal output and H output setting immediately after reset release, and P16 becomes L output setting after reset release.

Address 00C616

Port P3 register

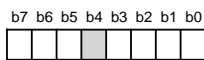

Port P3 register (P3) [Address 00C616]

B	Name	Functions	After reset	R	W
0	Port P3 register	Port P3 ₀ data	Indeterminate	R	W
1		Port P3 ₁ data	Indeterminate	R	W
2	Switch bit of I ² C-BUS interface and port P3 (BSEL20) (See note)	0: Port P3 ₀ , Port P3 ₁ 1: I ² CBUS (SDA3,SCL3)	0	R	W
3	SCL3/P3 ₁ -SCL1/P1 ₁ SDA3/P3 ₀ -SDA1/P1 ₃ Course connection control bit (BSEL21)	0: Connection 1: Cutting	0	R	W
4	Nothing is assigned. This bit is write disable bit. When this bit is read out, the value is "0."		0	R	-
5	Port P3 register	Port P3 ₅ data	Indeterminate	R	-
6		Port P3 ₆ data	Indeterminate	R	-
7		Port P3 ₇ data	Indeterminate	R	-

Notes • For the ports used as the Multi-master I²C-BUS interface, set their direction registers to 1.
• To use SCL3 and SDA3, set the I²C Control Register (address 00F916) bits 6-7 to 0.

Address 00C7₁₆

Port P3 direction register

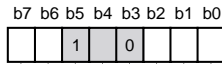

Port P3 direction register (D3) [Address 00C7₁₆]

B	Name	Functions	After reset	R	W
0	Port P3 direction register (See note 1)	0 : Port P3 ₀ input 1 : Port P3 ₀ output	0	R	W
1		0 : Port P3 ₁ input 1 : Port P3 ₁ output	0	R	W
2	OUTOutput selection bit (OUTS) (See note 2)	0 : 2 value output 1 : 3 value output	0	R	W
3	Fix this bit to "0."		0	R	W
4	Nothing is assigned fix this bits. When this bit are read out, the value are "0."		0	R	—
5	Fix this bit to "1."		0	R	—
6	Timer 3 (T3SC)	Refer to explanation of a timer	0	R	W
7	Timer 2 (T2SC)	0 : P2 ₄ input 1 : P1 ₆ input	0	R	W

- Notes** 1: When using the port as the I²C-BUS interface, set the Port P3 Direction Register to 1.
2: Use the Clock Control Register 3 (address 0212₁₆) bit 5 to select the binary output level of OUT.

Address 00CA₁₆

Port P5 register

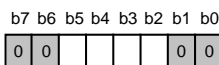

Port P5 register (P5) [Address 00CA₁₆]

B	Name	Functions	After reset	R	W
0, 1	Fix these bits to "0."		Indeterminate	R	W
2	Port P5 register	Port P5 ₂ data	Indeterminate	R	W
3		Port P5 ₃ data	Indeterminate	R	W
4		Port P5 ₄ data	Indeterminate	R	W
5		Port P5 ₅ data	Indeterminate	R	W
6	Fix these bits to "0."		Indeterminate	—	W
7			Indeterminate	R	W

Address 00CB₁₆OSD Port Control Register

b7 b6 b5 b4 b3 b2 b1 b0
 0 0 0 0 0 0 0 0

OSD port control register (PF) [Address 00CB₁₆]

B	Name	Functions	After reset	R	W
0, 1	Fix these bits to "0."		0	R	—
2	Port P5 ₂ output signal selection bit (PF2)	0 : B signal output 1 : Port P5 ₂ output	0	R	W
3	Port P5 ₃ output signal selection bit (PF3)	0 : G signal output 1 : Port P5 ₃ output	0	R	W
4	Port P5 ₄ output signal selection bit (PF4)	0 : R signal output 1 : Port P5 ₄ output	0	R	W
5	Port P5 ₅ output signal selection bit (PF5)	0 : OUT signal output 1 : Port P5 ₅ output	0	R	W
6	Fix these bit to "0."		Indeterminate	—	W
7			0	R	W

Address 00CC₁₆Timer return setting register

b7 b6 b5 b4 b3 b2 b1 b0
 1 1 0 0 0 0 0 0

Timer return setting register (TMS) [Address 00CC₁₆]

B	Name	Functions	After reset	R	W
0 to 4	Fix these bits to "0."		0	R	W
5,6	Fix this bit to "1."		0	R	W
7	STOP mode return selection bit (TMS)	0: Timer Count "07FF ₁₆ " 1: Timer Count Variable	0	R	W

Address 00CD₁₆

Clock control register 1

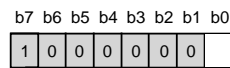
Clock control register 1 (CC1) [Address 00CD₁₆]

B	Name	Functions	After reset	R	W
0	System clock generating circuit control bit (CC10)	0: Operation 1: Stop	0	R	W
1 to 6	Fix these bits to "0"		0	R	W
7	Fix these bits to "1"		0	R	W

Address 00D0₁₆

OSD Control Register

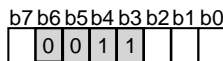
OSD control register (OC) [Address 00D0₁₆]

B	Name	Functions	After reset	R	W
0	OSD control bit (OC0) (See note 1)	0 : All-blocks display off 1 : All-blocks display on	0	R	W
1	Automatic solid space control bit (OC1)	0 : OFF 1 : ON	0	R	W
2	Window control bit (OC2)	0 : OFF 1 : ON	0	R	W
3, 4	Fix these bits to "1."		0	R	W
5, 6	Fix these bits to "0."		0	R	W
7	Pre-divide ratio selection bit (OC7) (See note 2)	0 : Divide ratio by the block control register 1 : Pre-divide ratios = X 1 for blocks 1 and 2	0	R	W

- Notes 1:** Even this bit is switched during display, the display screen remains unchanged until a rising (falling) of the next VSYNC
- 2:** This bit's priority is higher than BC₁₄ of Block Control Register *i* setting.
The pre-divide ratio 1 cannot be used in CD OSD mode.

Address 00D1₁₆Horizontal Position Register

b7 b6 b5 b4 b3 b2 b1 b0

Horizontal position register (HP) [Address 00D1₁₆]

B	Name	Functions	After reset	R	W
0 to 6	Horizontal display start position control bits (HP0 to HP6)	Horizontal display start position $4T_{osc} \times n$ (n: setting value, T _{osc} : OSD oscillation cycle)	0	R	W
7	Nothing is assigned. This bit is a write disable bit. When this bit is read out, the value is "0."		0	R	—

Note: The setting value synchronizes with the V SYNC.**Address 00D2₁₆, 00D3₁₆**Block Control register i

b7 b6 b5 b4 b3 b2 b1 b0

Block control register i (BCi) (i=1, 2) [Addresses 00D2₁₆ and 00D3₁₆]

B	Name	Functions	After reset	R	W
0, 1	Display mode selection bits (BCi0, BCi1) (See note 4)	b1 b0 0 0: Display OFF 0 1: OSD1 mode 1 0: OSD2 mode (Border OFF) 1 1: OSD2 mode (Border ON) / CD OSD mode (Border OFF)	Indeterminate	R	W
2, 3	Dot size selection bits (BCi2, BCi3) (See note 1)	b4 b3 b2 Pre-divide Ratio Dot Size 0 0 0 × 2 1T _c × 1/2H 0 0 1 1T _c × 1H 0 1 0 2T _c × 2H 0 1 1 3T _c × 3H	Indeterminate	R	W
4	Pre-divide ratio selection bit (BCi4)	0 0 0 × 3 1T _c × 1/2H 1 0 1 1T _c × 1H 1 1 0 2T _c × 2H 1 1 1 3T _c × 3H	Indeterminate	R	W
5	Output control bit (BCi5)	0: 2 value output control 1: 3 value output control (See note 3)	Indeterminate	R	W
6	Vertical display start position control bit (BCi6)	BC16: Block 1 BC26: Block 1	Indeterminate	R	W
7	Window top/bottom boundary control bit (BCi7)	BC17: Window top boundary BC27: Window bottom boundary	Indeterminate	R	W

Notes 1: T_c is OSD clock cycle divided in pre-divide circuit.**2:** H is HSYNC.**3:** Refer to the corresponding figure 8.10.18.**4:** Selection in OSD2 mode / CD OSD mode is performed in the bits 0 and 1 of color dot OSD control registration.

Address 00D4₁₆, 00D5₁₆

Vertical Position Register i

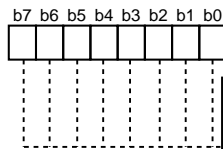

Vertical position register i (VPi) (i = 1 and 2) [Addresses 00D4₁₆, 00D5₁₆]

B	Name	Functions	After reset	R _i W _i
0 to 7	Vertical display start position control bits (VPi0 to VPi7) (See notes)	Vertical display start position = $T_H \times (BCi6 \times 16^2 + n)$ (n: setting value, TH: HSYNC cycle, BCi6: bit 6 of block control register i)	Indeterminate	R _i W _i

- Notes** 1: Set values except "00₁₆" to VPi when BCi6 is "0."
 2: When OS21 of OSD control register 2 = "0", TH = 1H_{SYNC}, and OS21 of OSD control register 2 = "1", TH = 2H_{SYNC}.

Address 00D6₁₆

Window Register 1

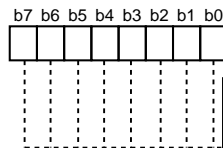

Window register 1 (WN1) [Address 00D6₁₆]

B	Name	Functions	After reset	R _i W _i
0 to 7	Window top boundary control bits (WN10 to WN17)	Window top border position = $T_H \times (BC17 \times 16^2 + n)$ (n: setting value, TH: HSYNC cycle, BC17: bit 7 of block control register 1)	Indeterminate	R _i W _i

- Notes** 1: Set values except "00₁₆" to WN1 when BC17 is "0."
 2: Set values fit for the following condition: WN1 < WN2.
 3: When OC21 of OSD control register 2 is "0", TH is 1 H_{SYNC}. And when "1", TH is 2 H_{SYNC}.

Address 00D7₁₆

Window Register 2

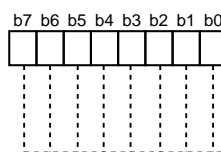

Window register 2 (WN2) [Address 00D7₁₆]

B	Name	Functions	After reset	R _i W _i
0 to 7	Window bottom boundary control bits (WN20 to WN27)	Window bottom border position = $T_H \times (BC27 \times 16^2 + n)$ (n: setting value, TH: HSYNC cycle, BC27: bit 7 of block control register 2)	Indeterminate	R _i W _i

- Notes** 1: Set values fit for the following condition: WN1 < WN2.
 2: When OC21 of OSD control register 2 is "0", TH is 1 H_{SYNC}. And when "1", TH is 2 H_{SYNC}.

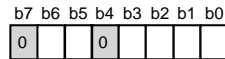
Address 00D8₁₆I/O Polarity Control RegisterI/O polarity control register (PC) [Address 00D8₁₆]

B	Name	Functions	After reset	R	W
0	H _{SYNC} input polarity switch bit (PC0)	0 : Positive polarity input 1 : Negative polarity input	0	R	W
1	V _{SYNC} input polarity switch bit (PC1)	0 : Positive polarity input 1 : Negative polarity input	0	R	W
2	R, G, B output polarity switch bit (PC2)	0 : Positive polarity output 1 : Negative polarity output	0	R	W
3	OUT1 output polarity switch bit (PC3)	0 : Positive polarity output 1 : Negative polarity output	0	R	W
5	Display dot line selection bit (PC5) (See note)	0 : "□" at even field "■" at odd field 1 : "■" at even field "□" at odd field	0	R	W
6	Field determination flag (PC6)	0 : Even field 1 : Odd field	1	R	—
4, 7	Fix these bits to "0."		0	R	W

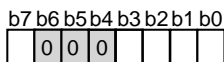
Note: Refer to the corresponding figure. 8.10.14.Address 00D9₁₆Raster Color RegisterRaster color register (RC) [Address 00D9₁₆]

B	Name	Functions	After reset	R	W
0	Raster color R control bit (RC0)	0 : No output 1 : Output	0	R	W
1	Raster color G control bit (RC1)	0 : No output 1 : Output	0	R	W
2	Raster color B control bit (RC2)	0 : No output 1 : Output	0	R	W
3	Raster color OUT control bit (RC3)	0 : No output 1 : Output	0	R	W
4 to 6	Fix these bits to "0."		0	R	W
7	Port function selection bit (RC7)	0 : XCIN, XCOUT 1 : P2 ₆ , P2 ₇	0	R	W

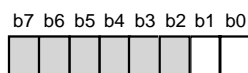
Address 00DA₁₆Color dot OSD control registerColor dot OSD control register (CDT) [Address 00DA₁₆]

B	Name	Functions	After reset	R	W
0	Color dot Block 1 Setting bit (CDT0)	0 : OSD2 mode 1 : CD OSD mode	Indeterminate	R	W
1	Color dot Block 2 Setting bit (CDT1)	0 : OSD2 mode 1 : CD OSD mode	Indeterminate	R	W
2 to 7	Nothing is assigned. This bit is write disable bit. When this bit is read out, the value is "Indeterminate."		Indeterminate	R	—

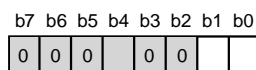
Address 00DB₁₆OSD Control Register 2OSD control register (OC2) [Address 00DB₁₆]

B	Name	Functions	After reset	R	W
0	Vertical character dot size (OC20)	0: 1H _{SYNC} (normal scan) 1: 2H _{SYNC} (by scan)	0	R	W
1	Vertical start position count selection bit (OC21)	0: Counts one time by 1H _{SYNC} (normal scan) 1: Counts two time by 1H _{SYNC} (by scan)	0	R	W
2	Fix these bit to "0."		0	R	W
3			0	R	—
4	Nothing is assigned. This bit is write disable bit. When this bit is read out, the value is "0."		Indeterminate	—	—
5 to 7	Fix these bits to "0."		0	R	W

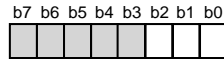
Address 00DC₁₆**Interrupt Input Polarity Register**Interrupt input polarity register (RE) [Address 00DC₁₆]

B	Name	Functions	After reset	R	W
0	INT1 polarity switch bit (INT1)	0 : Positive polarity 1 : Negative polarity	0	R	W
1	INT2 polarity switch bit (INT2)	0 : Positive polarity 1 : Negative polarity	0	R	W
2	INT3 polarity switch bit (INT3)	0 : Positive polarity 1 : Negative polarity	0	R	W
3 to 7	Nothing is assigned. These bits are write disable bits. When these bits are read out, the values are "0."		0	R	—

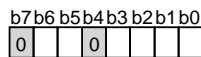
Address 00EB₁₆**Serial I/O Mode Register**Serial I/O mode register (SM) [Address 00EB₁₆]

B	Name	Functions	After reset	R	W
0, 1	Internal synchronous clock selection bits (SM0, SM1)	b1 b0 0 0: f(XIN)/8 or f(XCIN)/8 0 1: f(XIN)/16 or f(XCIN)/16 1 0: f(XIN)/32 or f(XCIN)/32 1 1: f(XIN)/64 or f(XCIN)/64	0	R	W
2	Synchronous clock selection bit (SM2)	0: External clock 1: Internal clock	0	R	W
3	Port function selection bit (SM3)	0: P20, P21 1: SCLK, SOUT	0	R	W
4	Fix this bit to "0."		0	R	W
5	Transfer direction selection bit (SM5)	0: LSB first 1: MSB first	0	R	W
6	Transfer clock input pin selection bit (SM6)	0: Input signal from SIN pin 1: Input signal from SOUT pin	0	R	W
7	Fix this bit to "0."		0	R	W

Address 00EC₁₆

A-D Control Register 1

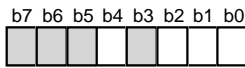

A-D control register 1 (AD1) [Address 00EC₁₆]

B	Name	Functions	After reset	R	W
0 to 2	Analog input pin selection (ADC10 to ADC12)	b2 b1 b0 0 0 0 : AD1 0 0 1 : AD2 0 1 0 : AD3 0 1 1 : AD4 1 0 0 : AD5 1 0 1 : AD6 1 1 0 : AD7 1 1 1 : AD8	0	R	W
3	This bit is a write disable bit. When this bit is read out, the value is "0."		0	R	—
4	Storage bit of comparison result (ADC14)	0: Input voltage < reference voltage 1: Input voltage > reference voltage	Indeterminate	R	—
5 to 7	Nothing is assigned. These bits are write disable bits. When these bits are read out, the values are "0."		0	R	—

Address 00ED₁₆

A-D Control Register 2

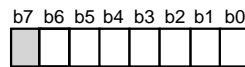

A-D control register 2 (AD2) [Address 00ED₁₆]

B	Name	Functions	After reset	R	W
0 to 6	D-A converter set bits (ADC20 to ADC25)	b6 b5 b4 b3 b2 b1 b0 0 0 0 0 0 0 0 : 1/256V _{cc} 0 0 0 0 0 0 1 : 3/256V _{cc} 0 0 0 0 0 1 0 : 5/256V _{cc} : : : 1 1 1 1 1 0 1 : 251/256V _{cc} 1 1 1 1 1 1 0 : 253/256V _{cc} 1 1 1 1 1 1 1 : 255/256V _{cc}	0	R	W
7	Nothing is assigned. This bit is a write disable bit. When these bits are read out, the values are "0."		0	R	—

Timer Mode Register 1

b7 b6 b5 b4 b3 b2 b1 b0

Timer mode register 1 (TM1) [Address 00F4 16]

B	Name	Functions	After reset	R	W
0	Timer 1 count source selection bit 1 (TM10)	0: f(X _{IN})/16 or f(X _{CIN})/16 (See note) 1: Count source selected by bit 5 of TM1	0	R	W
1	Timer 2 count source selection bit 1 (TM11)	0: Count source selected by bit 4 of TM1 1: External clock from TIM2 pin	0	R	W
2	Timer 1 count stop bit (TM12)	0: Count start 1: Count stop	0	R	W
3	Timer 2 count stop bit (TM13)	0: Count start 1: Count stop	0	R	W
4	Timer 2 count source selection bit 2 (TM14)	0: f(X _{IN})/16 or f(X _{CIN})/16 (See note) 1: Timer 1 overflow	0	R	W
5	Timer 1 count source selection bit 2 (TM15)	0: f(X _{IN})/4096 or f(X _{CIN})/4096 (See note) 1: External clock from TIM2 pin	0	R	W
6	Timer 5 count source selection bit 2 (TM16)	0: Timer 2 overflow 1: Timer 4 overflow	0	R	W
7	Timer 6 internal count source selection bit (TM17)	0: f(X _{IN})/16 or f(X _{CIN})/16 (See note) 1: Timer 5 overflow	0	R	W

Note: Either f(X_{IN}) or f(X_{CIN}) is selected by bit 7 of the CPU mode register.

Address 00F5₁₆

Timer Mode Register 2

b7 b6 b5 b4 b3 b2 b1 b0

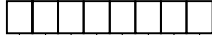
Timer mode register 2 (TM2) [Address 00F5₁₆]

B	Name	Functions	After reset	R	W
0	Timer 3 count source selection bit (TM20)	(b6 at address 00C7 ₁₆) ↓ b0 0 0: f(X _{IN})/16 or f(X _{CIN})/16 (See note) 1 0: f(X _{CIN}) 0 1: 1 1: } External clock from TIM3 pin	0	R	W
1, 4	Timer 4 count source selection bits (TM21, TM24)	b4 b1 0 0: Timer 3 overflow signal 0 1: f(X _{IN})/16 or f(X _{CIN})/16 (See note) 1 0: f(X _{IN})/2 or f(X _{CIN})/2 (See note) 1 1: f(X _{CIN})	0	R	W
2	Timer 3 count stop bit (TM22)	0: Count start 1: Count stop	0	R	W
3	Timer 4 count stop bit (TM23)	0: Count start 1: Count stop	0	R	W
5	Timer 5 count stop bit (TM25)	0: Count start 1: Count stop	0	R	W
6	Timer 6 count stop bit (TM26)	0: Count start 1: Count stop	0	R	W
7	Timer 5 count source selection bit 1 (TM27)	0: f(X _{IN})/16 or f(X _{CIN})/16 (See note) 1: Count source selected by bit 6 of TM1	0	R	W

Note: Either f(X_{IN}) or f(X_{CIN}) is selected by bit 7 of the CPU mode register.

Address 00F6₁₆I²C Data Shift Register

b7 b6 b5 b4 b3 b2 b1 b0

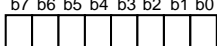
I²C data shift register 1 (S0) [Address 00F6₁₆]

B	Name	Functions	After reset	R	W
0 to 7	D0 to D7	This is an 8-bit shift register to store receive data and write transmit data.	Indeterminate	R	W

Note: To write data into the I²C data shift register after setting the MST bit to "0" (slave mode), keep an interval of 8 machine cycles or more.

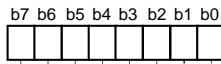
Address 00F7₁₆I²C Address RegisterI²C address register (S0D) [Address 00F7₁₆]

B	Name	Functions	After reset	R	W
0	Read/write bit (RBW)	<Only in 10-bit addressing (in slave) mode> The last significant bit of address data is compared. 0: Wait the first byte of slave address after START condition (read state) 1: Wait the first byte of slave address after RESTART condition (write state)	0	R	—
1 to 7	Slave address (SAD0 to SAD6)	<In both modes> The address data is compared.	0	R	W

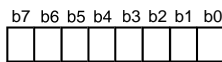
Address 00F8₁₆I²C Status RegisterI²C status register (S1) [Address 00F8₁₆]

B	Name	Functions	After reset	R	W
0	Last receive bit (LRB) (See note)	0 : Last bit = "0" 1 : Last bit = "1" (See note)	Indeterminate	R	—
1	General call detecting flag (AD0) (See note)	0 : No general call detected 1 : General call detected (See note)	0	R	—
2	Slave address comparison flag (AAS) (See note)	0 : Address mismatch 1 : Address match (See note)	0	R	—
3	Arbitration lost detecting flag (AL) (See note)	0 : Not detected 1 : Detected (See note)	0	R	—
4	I ² C-BUS interface interrupt request bit (PIN)	0 : Interrupt request issued 1 : No interrupt request issued	1	R	W
5	Bus busy flag (BB)	0 : Bus free 1 : Bus busy	0	R	W
6, 7	Communication mode specification bits (TRX, MST)	b7 b6 0 0 : Slave receive mode 0 1 : Slave transmit mode 1 0 : Master receive mode 1 1 : Master transmit mode	0	R	W

Note : These bits and flags can be read out, but cannot be written.

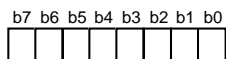
I²C Control RegisterI²C control register (S1D) [Address 00F9₁₆]

B	Name	Functions	After reset	R;W
0 to 2	Bit counter (Number of transmit/recieve bits) (BC0 to BC2)	b2 b1 b0 0 0 0 : 8 0 0 1 : 7 0 1 0 : 6 0 1 1 : 5 1 0 0 : 4 1 0 1 : 3 1 1 0 : 2 1 1 1 : 1	0	R;W
3	I ² C-BUS interface use enable bit (ESO)	0 : Disabled 1 : Enabled	0	R;W
4	Data format selection bit(ALS)	0 : Addressing mode 1 : Free data format	0	R;W
5	Addressing format selection bit (10BIT SAD)	0 : 7-bit addressing format 1 : 10-bit addressing format	0	R;W
6, 7	Connection control bits between I ² C-BUS interface and ports (BSEL0, BSEL1)	b7 b6 Connection port (See note) 0 0: None 0 1: SCL1, SDA1 1 0: SCL2, SDA2 1 1: SCL1, SDA1 SCL2, SDA2	0	R;W

Note: • Set the corresponding direction register to "1" to use the port as multi-master I²C-BUS interface.
• To use SCL1, SDA1, SCL2 and SDA2, set the port P3 Register (address 00C6₁₆) bit 2 to 0.

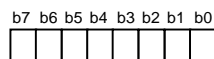
I²C Clock Control RegisterI²C clock control register (S2) [Address 00FA₁₆]

B	Name	Functions	After reset	R	W		
0 to 4	SCL frequency control bits (CCR0 to CCR4)	Setup value of CCR4–CCR0	Standard clock mode	0	R	W	
		00 to 02	Setup disabled				Setup disabled
		03	Setup disabled				333
		04	Setup disabled				250
		05	100				400 (See note)
		06	83.3				166
		:	500/CCR value				1000/CCR value
		1D	17.2				34.5
		1E	16.6				33.3
		1F	16.1				32.3
		(ϕ = at 4 MHz, unit : kHz)					
5	SCL mode specification bit (FAST MODE)	0: Standard clock mode 1: High-speed clock mode	0	R	W		
6	ACK bit (ACK BIT)	0: ACK is returned. 1: ACK is not returned.	0	R	W		
7	ACK clock bit (ACK)	0: No ACK clock 1: ACK clock	0	R	W		

Notes 1. At 400kHz in the high-speed clock mode, the duty is as below .
 "0" period : "1" period = 3 : 2
 In the other cases, the duty is as below.
 "0" period : "1" period = 1 : 1

Address 00FB₁₆

CPU Mode Register

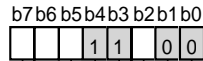

CPU mode register (CM) [Address 00FB₁₆]

B	Name	Functions	After reset	R/W
0, 1	Processor mode bits (CM0, CM1)	b1 b0 0 0: Single-chip mode 0 1: 1 0: 1 1: } Not available	0	R/W
2	Stack page selection bit (CM2) (See note1)	0: 0 page 1: 1 page	1	R/W
3, 4	Fix these bits to "1."		1	R/W
5	XcOUT drivability selection bit (CM5)	0: LOW drive 1: HIGH drive	1	R/W
6	Main Clock (XIN-XOUT) stop bit (CM6)	0: Oscillating 1: Stopped	0	R/W
7	Internal system clock selection bit (CM7)	0: XIN-XOUT selected (high-speed mode) 1: XcIN-XcOUT selected (low-speed mode)	0	R/W

Note 1: This bit is set to "1" after the reset release.

Address 00FC₁₆

Interrupt Request Register 1

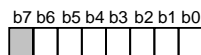

Interrupt request register 1 (IREQ1) [Address 00FC₁₆]

B	Name	Functions	After reset	R/W
0	Timer 1 interrupt request bit (TM1R)	0 : No interrupt request issued 1 : Interrupt request issued	0	R : *
1	Timer 2 interrupt request bit (TM2R)	0 : No interrupt request issued 1 : Interrupt request issued	0	R : *
2	Timer 3 interrupt request bit (TM3R)	0 : No interrupt request issued 1 : Interrupt request issued	0	R : *
3	Timer 4 interrupt request bit (TM4R)	0 : No interrupt request issued 1 : Interrupt request issued	0	R : *
4	OSD interrupt request bit (OSDR)	0 : No interrupt request issued 1 : Interrupt request issued	0	R : *
5	VSYNC interrupt request bit (VSCR)	0 : No interrupt request issued 1 : Interrupt request issued	0	R : *
6	INT3 external interrupt request bit (IN3R)	0 : No interrupt request issued 1 : Interrupt request issued	0	R : *
7	Nothing is assigned. This bit is a write disable bit. When this bit is read out, the value is "0."		0	R : —

*: "0" can be set by software, but "1" cannot be set.

Address 00FD₁₆Interrupt Request Register 2

b7 b6 b5 b4 b3 b2 b1 b0

0 0 0 0 0 0 0 0

Interrupt request register 2 (IREQ2) [Address 00FD₁₆]

B	Name	Functions	After reset	R	W
0	INT1 external interrupt request bit (IN1R)	0 : No interrupt request issued 1 : Interrupt request issued	0	R	*
1	Fix this bit to "0."		0	R	*
2	Serial I/O interrupt request bit (SIR)	0 : No interrupt request issued 1 : Interrupt request issued	0	R	*
3	f(XIN)/4096 interrupt request bit (CKR)	0 : No interrupt request issued 1 : Interrupt request issued	0	R	*
4	INT2 external interrupt request bit (IN2R)	0 : No interrupt request issued 1 : Interrupt request issued	0	R	*
5	Multi-master I ² C-BUS interrupt request bit (IICR)	0 : No interrupt request issued 1 : Interrupt request issued	0	R	*
6	Timer 5 • 6 interrupt request bit (TM56R)	0 : No interrupt request issued 1 : Interrupt request issued	0	R	*
7	Fix this bit to "0."		0	R	W

*: "0" can be set by software, but "1" cannot be set.

Address 00FE₁₆Interrupt Control Register 1

b7 b6 b5 b4 b3 b2 b1 b0

0 0 0 0 0 0 0 0

Interrupt control register 1 (ICON1) [Address 00FE₁₆]

B	Name	Functions	After reset	R	W
0	Timer 1 interrupt enable bit (TM1E)	0 : Interrupt disabled 1 : Interrupt enabled	0	R	W
1	Timer 2 interrupt enable bit (TM2E)	0 : Interrupt disabled 1 : Interrupt enabled	0	R	W
2	Timer 3 interrupt enable bit (TM3E)	0 : Interrupt disabled 1 : Interrupt enabled	0	R	W
3	Timer 4 interrupt enable bit (TM4E)	0 : Interrupt disabled 1 : Interrupt enabled	0	R	W
4	OSD interrupt enable bit (OSDE)	0 : Interrupt disabled 1 : Interrupt enabled	0	R	W
5	VSYNC interrupt enable bit (VSCE)	0 : Interrupt disabled 1 : Interrupt enabled	0	R	W
6	INT3 external interrupt enable bit (IN3E)	0 : Interrupt disabled 1 : Interrupt enabled	0	R	W
7	Nothing is assigned. This bit is a write disable bit. When this bit is read out, the value is "0."		0	R	—

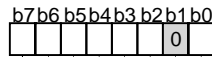
Address 00FF₁₆Interrupt Control Register 2Interrupt control register 2 (ICON2) [Address 00FF₁₆]

B	Name	Functions	After reset	R	W
0	INT1 external interrupt enable bit (IN1E)	0 : Interrupt disabled 1 : Interrupt enabled	0	R	W
1	Fix this bit to "0."		0	R	W
2	Serial I/O interrupt enable bit (SIE)	0 : Interrupt disabled 1 : Interrupt enabled	0	R	W
3	f(Xin)/4096 interrupt enable bit (CKE)	0 : Interrupt disabled 1 : Interrupt enabled	0	R	W
4	INT2 external interrupt enable bit (IN2E)	0 : Interrupt disabled 1 : Interrupt enabled	0	R	W
5	Multi-master I ² C-BUS interface interrupt enable bit (IICE)	0 : Interrupt disabled 1 : Interrupt enabled	0	R	W
6	Timer 5 • 6 interrupt enable bit (TM56E)	0 : Interrupt disabled 1 : Interrupt enabled	0	R	W
7	Timer 5 • 6 interrupt switch bit (TM56C)	0 : Timer 5 1 : Timer 6	0	R	W

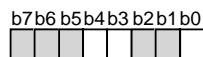
Address 0208₁₆PWM Mode Register 1PWM mode register 1 (PM1) [Address 0208₁₆]

B	Name	Functions	After reset	R	W
0	PWM counts source selection bit (PM10)	0 : Count source supply 1 : Count source stop	0	R	W
1, 2	Nothing is assigned. These bits are write disable bits. When these bits are read out, the values are "0."		Indeterminate	R	—
3	PWM output polarity selection bit (PM13)	0 : Positive polarity 1 : Negative polarity	0	R	W
4	DA output polarity selection bit (PM14)	0 : Positive polarity 1 : Negative polarity	0	R	W
5 to 7	Nothing is assigned. These bits are write disable bits. When these bits are read out, the values are "0."		Indeterminate	R	—

Address 0209₁₆

PWM Mode Register 2

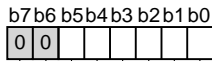

PWM mode register 2 (PM2) [Address 0209₁₆]

B	Name	Functions	After reset	R : W
0	P0 ₀ /PWM0 output selection bit (PM20)	0 : P0 ₀ output 1 : PWM0 output	0	R : W
1	P0 ₁ /PWM1 output selection bit (PM21)	0 : P0 ₁ output 1 : PWM1 output	0	R : W
2	P0 ₂ /PWM2 output selection bit (PM22)	0 : P0 ₂ output 1 : PWM2 output	0	R : W
3	P0 ₃ /PWM3 output selection bit (PM23)	0 : P0 ₃ output 1 : PWM3 output	0	R : W
4	P0 ₄ /PWM4 output selection bit (PM24)	0 : P0 ₄ output 1 : PWM4 output	0	R : W
5	P0 ₀ /PWM0/DA output selection bit (PM25)	0 : P0 ₀ PWM0 output 1 : DA output	0	R : W
6, 7	Fix these bits to "0."		0	R : W

Address 020E₁₆

ROM Correction Enable Register

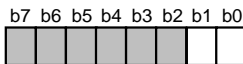

ROM correction enable register (RCR) [Address 020E₁₆]

B	Name	Functions	After reset	R : W
0	Vector 1 enable bit (RC0)	0: Disabled 1: Enabled	0	R : W
1	Vector 2 enable bit (RC1)	0: Disabled 1: Enabled	0	R : W
2 to 7	Nothing is assigned. These bits are write disable bits. When these bits are read out, the values are "0."		0	R : —

Address 0210₁₆

Clock frequency set register

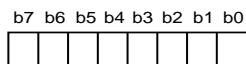

Clock frequency set register(CFS) [Address 0210₁₆]

B	Name	Functions	After reset	R	W	
0 to 7	Clock frequency bit (CFS 0 to 7)	Clock frequency (Note)		0E	R	W
		Setting value(Limitation)	Frequency(MHz)			
		0A	22			
		0B	24			
		0C	26			
		0D	28			

Note: Do not set other than the values shown above to CFS.
Then, must to use at f(X_{IN}) = 8 MHz.

Address 0211₁₆

Clock control register 2

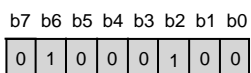

Clock control register 2 (CC2) [Address 0211₁₆]

B	Name	Functions	After reset	R	W
0,1	Fix these bits to "0"		0	R	W
2	Fix this bit to "1"		0	R	W
3 to 5	Fix this bit to "0"		0	R	W
6	Fix these bits to "1"		0	R	W
7	Fix these bits to "0"		0	R	W

Clock control register 3

b7 b6 b5 b4 b3 b2 b1 b0

	0		0	0	0	0	0
--	---	--	---	---	---	---	---

Clock control register 3 (CC3) [Address 0212₁₆]

B	Name	Functions	After reset	R	W
0 to 4	Fix these bits to "0"		0	R	W
5	R,G,B,OUT Output amplitude level selection bit (CC35)	0: 0V–V _{cc} 1: 0V–About 0.6V _{cc}	0	R	W
6	Fix this bit to "0"		0	R	W
7	P1 ₀ function-selection bit (CC37)	(Note) 0: Clock control signal 1: P1 ₀ I/O	0	R	W

Note: When used as the clock control signal, set the Port 1 Direction Register (address 00C3₁₆) bit 0 to 1.

19. PACKAGE OUTLINE

42P2R-A/E

Plastic 42pin 450mil SSOP

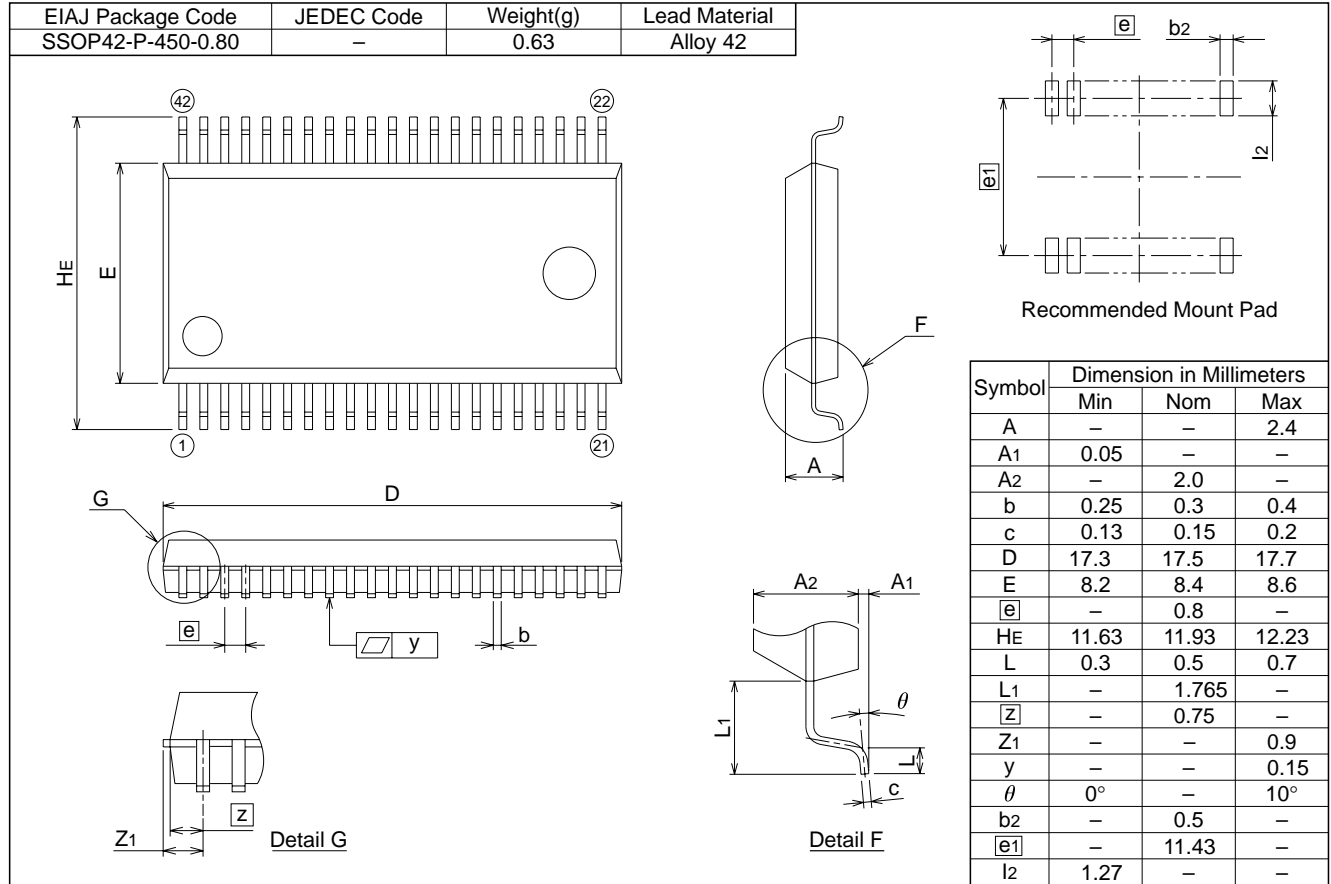

42P4B

Plastic 42pin 600mil SDIP

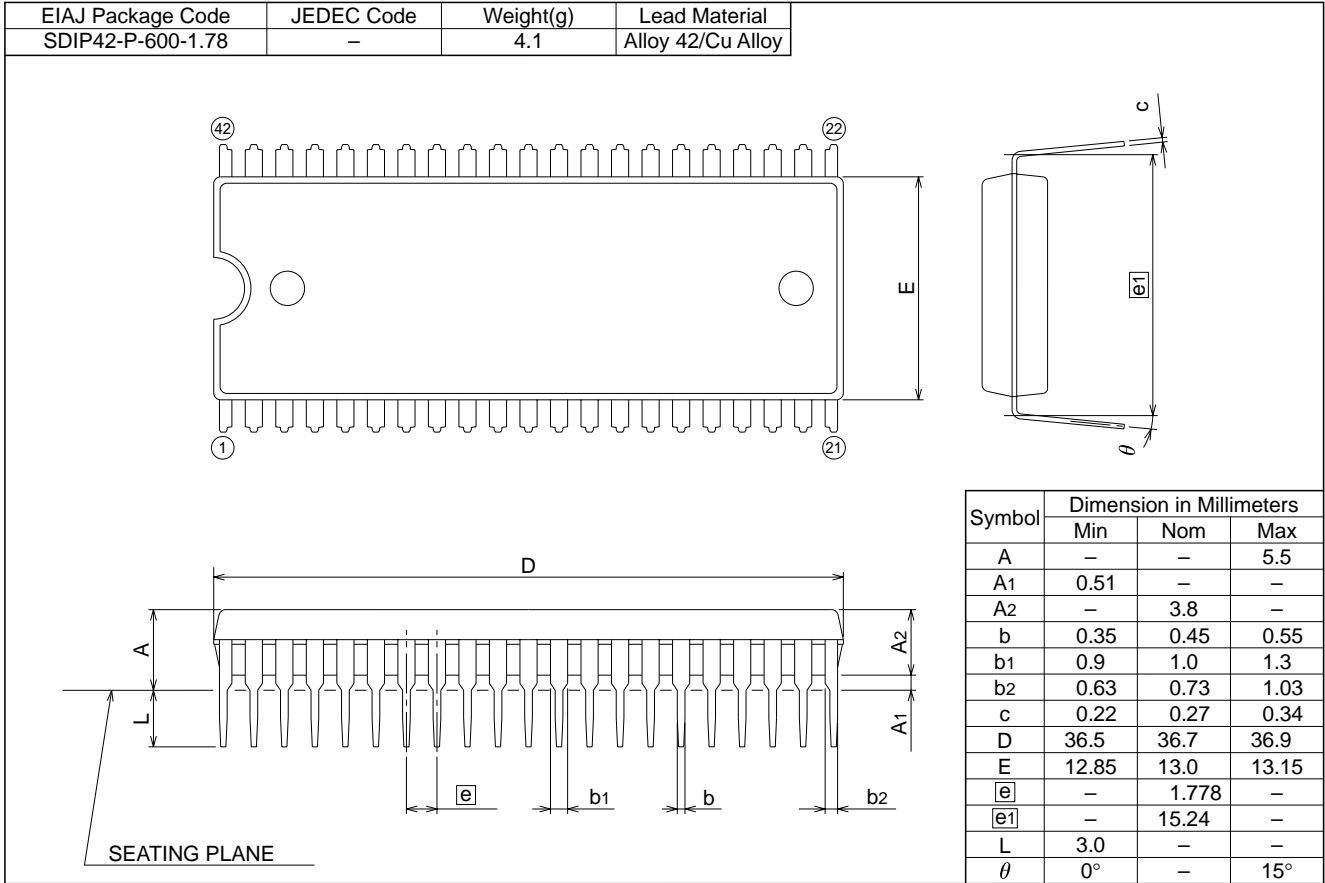

Sales Strategic Planning Div. Nippon Bldg., 2-6-2, Ohte-machi, Chiyoda-ku, Tokyo 100-0004, Japan

Keep safety first in your circuit designs!

1. Renesas Technology Corporation puts the maximum effort into making semiconductor products better and more reliable, but there is always the possibility that trouble may occur with them. Trouble with semiconductors may lead to personal injury, fire or property damage.

Remember to give due consideration to safety when making your circuit designs, with appropriate measures such as (i) placement of substitutive, auxiliary circuits, (ii) use of nonflammable material or (iii) prevention against any malfunction or mishap.

Notes regarding these materials

1. These materials are intended as a reference to assist our customers in the selection of the Renesas Technology Corporation product best suited to the customer's application; they do not convey any license under any intellectual property rights, or any other rights, belonging to Renesas Technology Corporation or a third party.
2. Renesas Technology Corporation assumes no responsibility for any damage, or infringement of any third-party's rights, originating in the use of any product data, diagrams, charts, programs, algorithms, or circuit application examples contained in these materials.
3. All information contained in these materials, including product data, diagrams, charts, programs and algorithms represents information on products at the time of publication of these materials, and are subject to change by Renesas Technology Corporation without notice due to product improvements or other reasons. It is therefore recommended that customers contact Renesas Technology Corporation or an authorized Renesas Technology Corporation product distributor for the latest product information before purchasing a product listed herein.

The information described here may contain technical inaccuracies or typographical errors.

Renesas Technology Corporation assumes no responsibility for any damage, liability, or other loss rising from these inaccuracies or errors.

Please also pay attention to information published by Renesas Technology Corporation by various means, including the Renesas Technology Corporation Semiconductor home page (<http://www.renesas.com>).

4. When using any or all of the information contained in these materials, including product data, diagrams, charts, programs, and algorithms, please be sure to evaluate all information as a total system before making a final decision on the applicability of the information and products. Renesas Technology Corporation assumes no responsibility for any damage, liability or other loss resulting from the information contained herein.
5. Renesas Technology Corporation semiconductors are not designed or manufactured for use in a device or system that is used under circumstances in which human life is potentially at stake. Please contact Renesas Technology Corporation or an authorized Renesas Technology Corporation product distributor when considering the use of a product contained herein for any specific purposes, such as apparatus or systems for transportation, vehicular, medical, aerospace, nuclear, or undersea repeater use.
6. The prior written approval of Renesas Technology Corporation is necessary to reprint or reproduce in whole or in part these materials.
7. If these products or technologies are subject to the Japanese export control restrictions, they must be exported under a license from the Japanese government and cannot be imported into a country other than the approved destination.
Any diversion or reexport contrary to the export control laws and regulations of Japan and/or the country of destination is prohibited.
8. Please contact Renesas Technology Corporation for further details on these materials or the products contained therein.



<http://www.renesas.com>

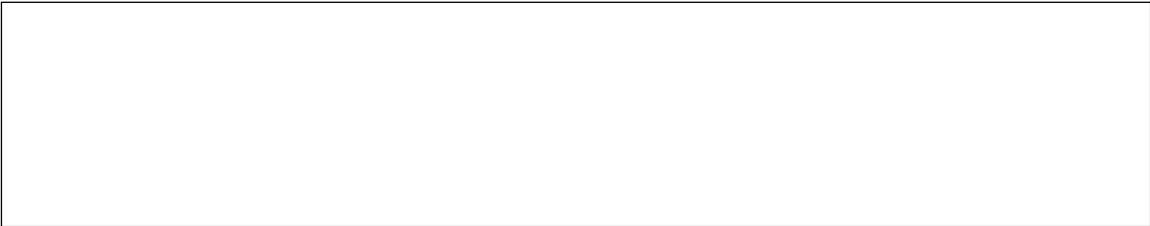

Copyright © 2003. Renesas Technology Corporation, All rights reserved. Printed in Japan.

REVISION DESCRIPTION LIST

M37161M8/MA/MF-XXXSP/FP,M37161EFSP/FP

Rev. No.	Revision Description	Rev. date
1.00	First Edition of PDF File	1125